

DU/DU-B

Dry Bearings



Designer's Handbook

Quality

All the products described in this handbook are manufactured under DIN ISO 9001/2 or QS 9000 approved quality management systems.



Technical approvals:

Tested and approved by MPA Stuttgart (for DUTM-B) for structural bearings for civil engineering applications.

Civil aviation authority (United Kingdom): CAA release for material, finished components and test methods.

Quality control committee of the United Kingdom Ministry of Defence under the heading of:

MOD DCL No.14 VGO4 AQAP4 for bearings, bushes, washers in metal and non-metal specifications.

French defence authority: RAO-2/6-86-155.

NATO authority: F21 07-AQAP4.

© by GLACIER GARLOCK BEARINGS

Formula Symbols and Designations

Formula Symbol	Unit	Designation
A	mm ²	Surface Area of DU bearing
A_M	mm ²	Surface Area of mating surface in contact with DU bearing (slideway)
a_B	-	Bearing size factor
a_C	-	Application factor for bore burnishing or machining
a_E	-	High load factor
a_{E1}	-	Specific load factor (slideways)
a_{E2}	-	Speed, temperature and material factor (slideways)
a_{E3}	-	Relative contact area factor (slideways)
a_L	-	Life correction constant
a_M	-	Mating surface material factor
a_T	-	Temperature application factor
B	mm	Nominal bush length
C	1/min	Dynamic load frequency
C_D	mm	Installed diametral clearance
C_i	mm	ID chamfer length
C_o	mm	OD chamfer length
C_T	-	Total number of dynamic load cycles
D_C	mm	Diameter of burnishing tool
D_{fl}	mm	Nominal bush flange OD
D_H	mm	Housing Diameter
D_i	mm	Nominal bush and thrust washer ID
$D_{i,a}$	mm	Bush ID when assembled in housing
D_J	mm	Shaft diameter
D_{Nth}	nvt	Max. thermal neutron dose
D_o	mm	Nominal bush and thrust washer OD
D_γ	Gy	Max. Gamma radiation dose
$d_{ch,1}$	mm	Checking block diameter
d_D	mm	Dowel hole diameter
d_L	mm	Oil hole diameter
d_P	mm	Pitch circle diameter for dowel hole
F	N	Bearing load
F_{ch}	N	Test force
F_i	N	Insertion force
f	-	friction

Formula Symbol	Unit	Designation
L	mm	Strip length
L_H	h	Bearing service life
L_S	mm	Length of stroke (slideway)
N	1/min	Rotational speed
N_{osz}	1/min	Oscillating movement frequency
\bar{p}	N/mm ²	Specific load
\bar{p}_{lim}	N/mm ²	Specific load limit
$\bar{p}_{sta,max}$	N/mm ²	Maximum static load
$\bar{p}_{dyn,max}$	N/mm ²	Maximum dynamic load
Q	-	Permissible number of cycles
R_a	mm	Surface roughness (DIN 4768, ISO/DIN 4287/1)
R_{OB}	Ω	Electrical resistance
S_3	mm	Bush wall thickness
S_{fl}	mm	Flange thickness
S_S	mm	Strip thickness
S_T	mm	Thrust washer thickness
T	°C	Temperature
T_a	mm	Depth Housing Recess
T_{amb}	°C	Ambient temperature
T_{max}	°C	Maximum temperature
T_{min}	°C	Minimum temperature
U	m/s	Sliding speed
W	mm	Strip width
W_u	mm	Maximum usable strip width
Z_T	-	Total number of cycles
α_1	1/10 ⁶ K	Coefficient of linear thermal expansion parallel to surface
α_2	1/10 ⁶ K	Coefficient of linear thermal expansion normal to surface
σ_c	N/mm ²	Compressive Yield strength
λ	W/mK	Thermal conductivity
φ	°	Angular displacement
η	Ns/mm ²	Dynamic Viscosity

Historical

The development of a polytetrafluoroethylene (PTFE) lined composite dry bearing material was first begun by the Glacier Metal Company Ltd in 1948 and patents were subsequently granted for the material during the 1950's.

Today DU is the most successful of composite bearing materials, combining the excellent dry bearing properties of PTFE with the mechanical properties of conventional metallic bearings, and has a wider range of performance and greater number of applications than probably any other bearing material.



Content

Quality	I	4 Data Sheet	22
Formula Symbols and Designations	II	4.1 Data for bearing design calculations	22
Historical	III	5 Lubrication	23
1 Introduction	5	5.1 Lubricants	23
1.1 Applications	5	5.2 Tribology	23
1.2 Characteristics and Advantages	5	Hydrodynamic lubrication	23
1.3 Basic Forms Available	5	Mixed film lubrication	24
1.4 Materials	6	Boundary lubrication	24
2 Material	7	5.3 Characteristics of Lubricated DU bearings	24
2.1 Structure	7	5.4 Design Guidance for Lubricated Applications	24
2.2 Dry Wear Mechanism	7	5.5 Clearances for lubricated operation	26
2.3 Physical, Mechanical and Electrical Properties	9	5.6 Mating Surface Finish for lubricated operation	26
2.4 Chemical Properties	10	5.7 Grooving for lubricated operation	26
Electrochemical Corrosion	10	5.8 Grease Lubrication	26
2.5 Frictional Properties	10	6 Bearing Assembly	27
3 Performance	12	Dimensions and Tolerances	27
3.1 Design Factors	12	6.1 Allowance for Thermal Expansion	27
Calculation	12	6.2 Tolerances for minimum clearance	27
3.2 Specific Load \bar{p}	12	Sizing	28
3.3 Specific Load Limit \bar{p}_{lim}	13	6.3 Counterface Design	28
3.4 Sliding Speed U	13	6.4 Installation	29
Continuous Rotation	13	Fitting of cylindrical bushes	29
Oscillating Movement	13	Fitting of flanged bushes	29
3.5 $\bar{p}U$ Factor	14	Insertion Forces	29
3.6 Application Factors	14	Alignment	30
Temperature	14	Sealing	30
Mating Surface	15	6.5 Axial Location	30
Bearing Size	15	Fitting of Thrust Washers	30
Bore Burnishing	16	Slideways	31
Type of Load	16	7 Modification	32
3.7 Calculation of Bearing Size ..	17	7.1 Cutting and Machining	32
Calculation for Bushes	17	Drilling Oil Holes	32
Calculation for Thrust Washers ..	17	Cutting Strip Material	32
Calculation for Slideways	17	7.2 Electroplating	32
3.8 Calculation of Bearing Service Life ..	18	DU Components	32
Specific load p	18	Mating Surfaces	32
High load factor a_E	18		
Modified $\bar{p}U$ Factor	18		
Estimation of bearing life L_H	19		
Bore Burnishing	19		
Slideways	19		
3.9 Worked Examples	20		

8	Standard Products	33	8.9	DU Strip	49
8.1	DU Cylindrical Bushes	33	8.10	DU-B Strip	49
8.2	DU Flanged Bushes	38	8.11	DU Strip - Inch sizes	49
8.3	DU Flanged Washers	40	9	Test Methods	50
8.4	DU Thrust Washer	41	9.1	Measurement of	
8.5	DU-B Cylindrical Bushes	42		Wrapped Bushes	50
8.6	DU-B Flanged Bushes	44		Test A of ISO 3547 Part 2	50
8.7	DU Cylindrical Bushes - Inch sizes	45		Test B (alternatively to Test A)	50
8.8	DU Thrust Washers - Inch sizes	48		Test C	50
				Measurement of Wall Thickness (alternatively to Test C)	50
				Test D	50

1 Introduction

The purpose of this handbook is to provide comprehensive technical information on the characteristics of DU™ bearings.

The information given permits designers to establish the correct size of bearing required and the expected life and performance.

Glacier Garlock Bearings Research and Development services are available to assist with unusual design problems.

Complete information on the range of DU standard stock products is given together with details of other DU products.

Glacier Garlock Bearings is continually refining and extending its experimental and theoretical knowledge and, therefore, when using this brochure it is always worth-while to contact the Company should additional information be required.

As it is impossible to cover all conditions of operation which arise in practice, customers are advised to carry out prototype testing wherever possible.

1.1 Applications

DU is suitable for

- rotating,
- oscillating,
- reciprocating and
- sliding movements.

Also available are DU related material compositions for specific applications, for

example when increased corrosion resistance of the bearing material is required due to

- atmospheric or environmental considerations
- food safety regulations

1.2 Characteristics and Advantages

- **DU requires no lubrication**
- **Provides maintenance free operation**
- **DU has a high \bar{p} U capability**
- **DU exhibits low wear rate**
- **Seizure resistant**
- **Suitable for temperatures from -200 to +280 °C**
- **High static and dynamic load capacity**
- **Good frictional properties with negligible stick-slip**
- **Resists solvents**
- **No water absorption and therefore dimensionally stable**
- **DU is electrically conductive and shows no electrostatic effects**
- **DU has good embedability and is tolerant of dusty environments**
- **Compact and light**
- **DU bearings are prefinished and require no machining after assembly**

1.3 Basic Forms Available

Standard Components available from stock.

These products are manufactured to International, National or Glacier Garlock Bearings standard designs.

Metric and Imperial sizes

- Cylindrical Bushes
- Flanged Bushes *
- Thrust Washers
- Flanged Washers *
- Strip Material

* Metric sizes only

1 Introduction



Fig. 1: Standard Components

Non-Standard Components not available from stock.

- These products are manufactured to customers' requirements with or without Glacier Garlock Bearings recommendations, and include for example
- Half Bearings
 - Flat Components
 - Deep Drawn Parts
 - Pressings
 - Stampings
 - Modified Standard Components

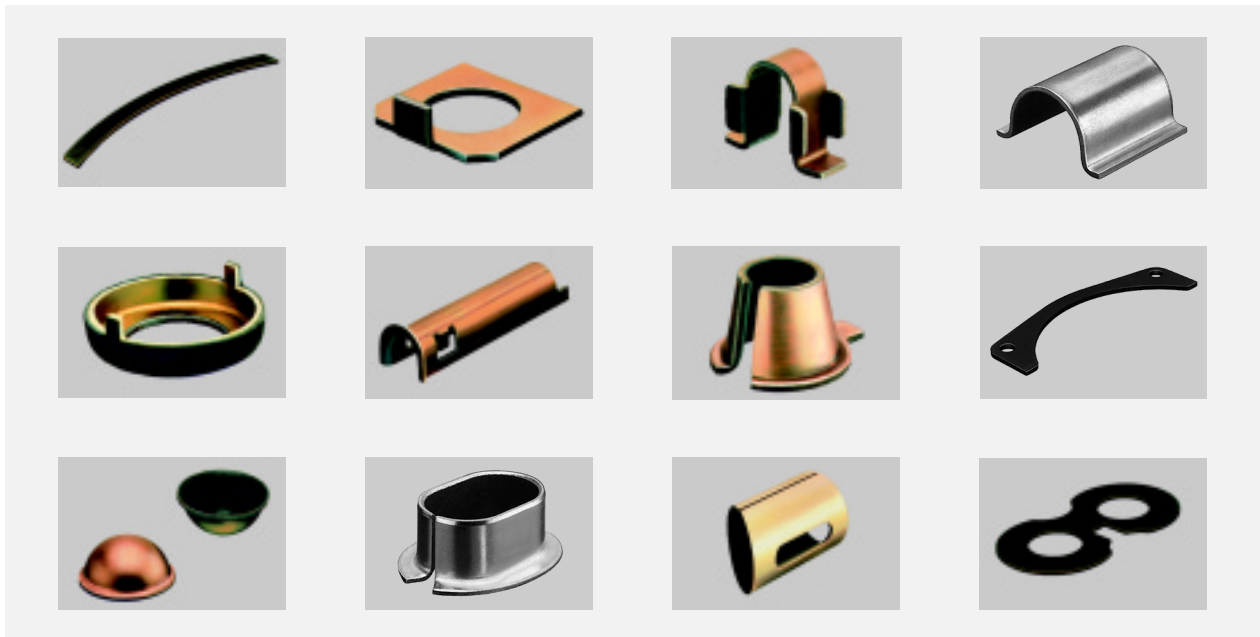

Fig. 2: Non-Standard Components

1.4 Materials

Material	Backing	Bearing Lining	Operating Temperature [°C]		Maximum Load \bar{p}_{lim} [N/mm ²]
			Minimum	Maximum	
DU	Steel	PTFE+Lead	-200	+280	250
DU-B	Bronze	PTFE+Lead	-200	+280	140

Table 1: Characteristics of DU and DU-B

2 Material

2.1 Structure

DU and DU-B take advantage of the outstanding dry bearing properties of Polytetrafluoroethylene (PTFE) and combines them with strength, stability and good wear resistance, excellent heat conductivity and low thermal expansion.

DU consists of three bonded layers: a steel backing strip and a porous bronze matrix,

impregnated and overlaid with the PTFE/lead bearing material.

DU-B also consists of three layers, with a bronze backing replacing the steel backing strip. The structure is otherwise the same as that of DU.

The bronze backing provides high corrosion resistance, anti magnetic properties and good thermal conductivity.

DU



Fig. 3: DU Microsection

DU-B



Fig. 4: DU-B Microsection

2.2 Dry Wear Mechanism

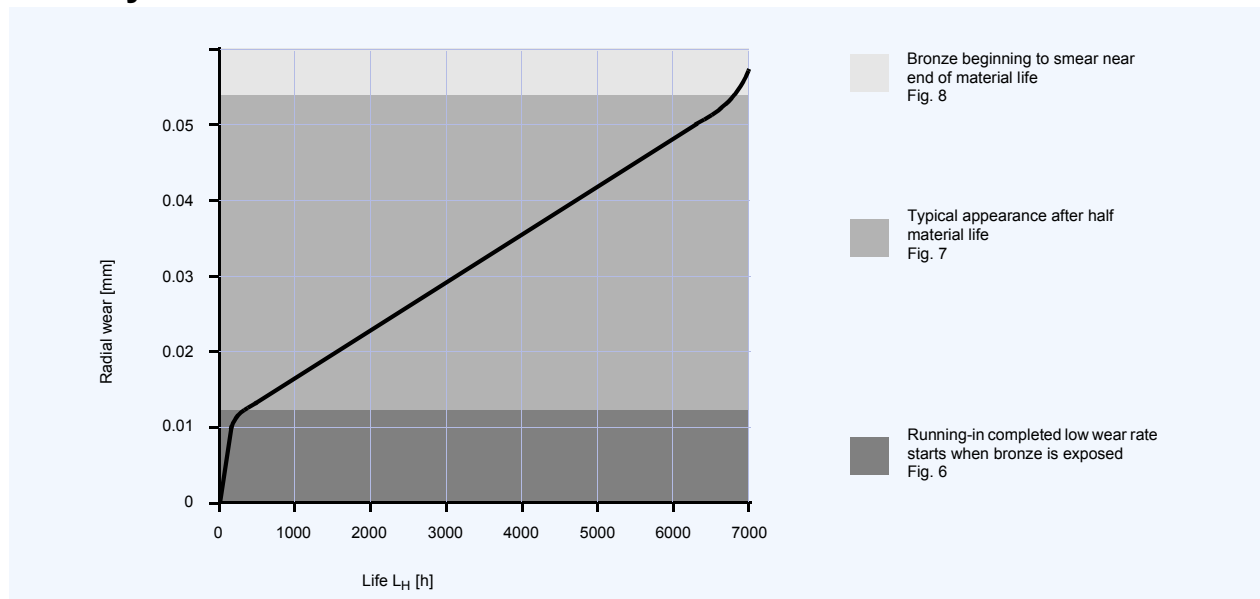

Fig. 5: Effect of wear on the DU bearing surface under dry operating conditions.

2 Material

During normal operation, a DU bearing quickly beds in and the PTFE/lead overlay material removed during this period, typically 0.015 mm, is transferred to the mating surface and forms a physically bonded lubricant film.

The rubbing surface of the bearing often acquires a grey-green colour and the bronze matrix can be seen exposed over about 10 % of the bearing surface. Any

excess of the PTFE/lead surface layer will be shed as fine feathery particles.

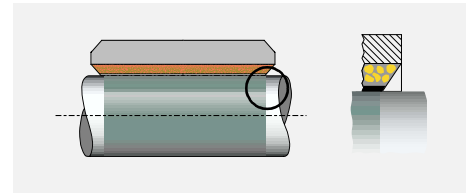

Fig. 6: Running-in

Following the running-in period the wear rate reduces to a minimum and the percentage of bronze exposed gradually increases.

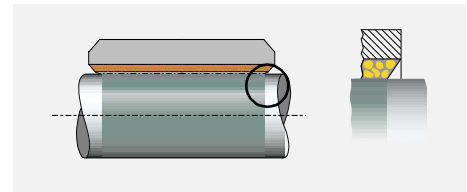

Fig. 7: After 50 % of useful life

After an extended period of operation the wear rate increases as the component approaches the end of its useful life as a self-lubricating bearing. At this stage at least 70 % of the bearing surface will be exposed bronze, and approximately 0.06 mm wear will have occurred.

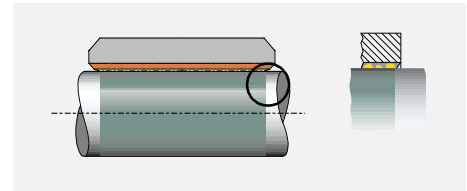

Fig. 8: End of useful life

Wear of Mating Surfaces

There is no measurable wear of mating surfaces made from recommended materials unless a DU bearing is operated

beyond its useful life or becomes contaminated with abrasive dirt.

2.3 Physical, Mechanical and Electrical Properties

Characteristic	Symbol	Value		Unit	Comments	
		DU	DU-B			
Physical Properties	Thermal Conductivity	λ	40	60	W/mK	after running in.
	Coefficient of linear thermal expansion :					measured on strip 1.9 mm thick.
	parallel to surface	α_1	11	18	$1/10^6 K$	
	normal to surface	α_2	30	36	$1/10^6 K$	
	Maximum Operating Temperature	T_{max}	+280	+280	$^{\circ}C$	
Minimum Operating Temperature	T_{min}	-200	-200	$^{\circ}C$		
Mechanical Properties	Compressive Yield Strength	σ_c	350	300	N/mm^2	measured on disc 25 mm diameter x 2.44 mm thick.
	Maximum Load					
	Static	$\bar{p}_{sta,max}$	250	140	N/mm^2	
	Dynamic	$\bar{p}_{dyn,max}$	140	140	N/mm^2	
Electrical Properties	Surface Resistance	R_{OB}	1 – 10	1 – 12	Ω	depends on applied pressure and contact area
Nuclear Radiation Resistance	Maximum Thermal Neutron dose	D_{Nth}	2×10^{15}	2×10^{15}	nvt	nvt = thermal neutron flux
	Maximum gamma ray dose	$D\gamma$	10^6	10^6	$Gy = J/kg$	1 Gray = 1 J/kg

Table 2: Properties of DU and DU-B

2.4 Chemical Properties

The following table provides an indication of the chemical resistance of DU and DU-B to various chemical media. It is recom-

ended that the chemical resistance is confirmed by testing if possible.

	Chemical	%	°C	DU	DU-B
Strong Acids	Hydrochloric Acid	5	20	-	-
	Nitric Acid	5	20	-	-
	Sulphuric Acid	5	20	-	-
Weak Acids	Acetic Acid	5	20	-	o
	Formic Acid	5	20	-	o
Bases	Ammonia	10	20	o	-
	Sodium Hydroxide	5	20	o	o
Solvents	Acetone		20	+	+
	Carbon Tetrachloride		20	+	+
Lubricants and Fuels	Paraffin		20	+	+
	Gasolene		20	+	+
	Kerosene		20	+	+
	Diesel Fuel		20	+	+
	Mineral Oil		70	o	o
	HFA-ISO46 High Water Fluid		70	o	o
	HFC-Water-Glycol		70	-	-
	HFD-Phosphate Ester		70	o	o
	Water		20	o	+
Sea Water		20	-	o	

Table 3: Chemical Resistance of DU and DU-B

+	Satisfactory: Corrosion damage is unlikely to occur.
o	Acceptable: Some corrosion damage may occur but this will not be sufficient to impair either the structural integrity or the tribological performance of the material.
-	Unsatisfactory: Corrosion damage will occur and is likely to affect either the structural integrity and/or the tribological performance of the material.

Electrochemical Corrosion

DU-B should not be used in conjunction with aluminium housings due to the risk of

electrochemical corrosion in the presence of water or moisture.

2.5 Frictional Properties

DU bearings show negligible 'stick-slip' and provide smooth sliding between adjacent surfaces. The coefficient of friction of DU depends upon:

- The specific load \bar{p} [N/mm²]
- The sliding speed U [m/s]
- The roughness of the mating running surface R_a [µm]
- The bearing temperature T [°C].

A typical relationship is shown in Fig. 9, which can be used as a guide to establish the actual friction under clean, dry conditions after running in.

Exact values may vary by ±20 % depending on operating conditions.

Before running in, the friction may be up to 50 % higher.

With frequent starts and stops, the static coefficient of friction is approximately equal

to, or even slightly less than the dynamic coefficient of friction.

After progressively longer periods of dwell under load (e.g. hours or days) the static coefficient of friction on the first movement may be between 1.5 and 3 times greater, particularly before running in.

Friction increases at bearing temperatures below 0 °C.

Where frictional characteristics are critical to a design they should be established by prototype testing.

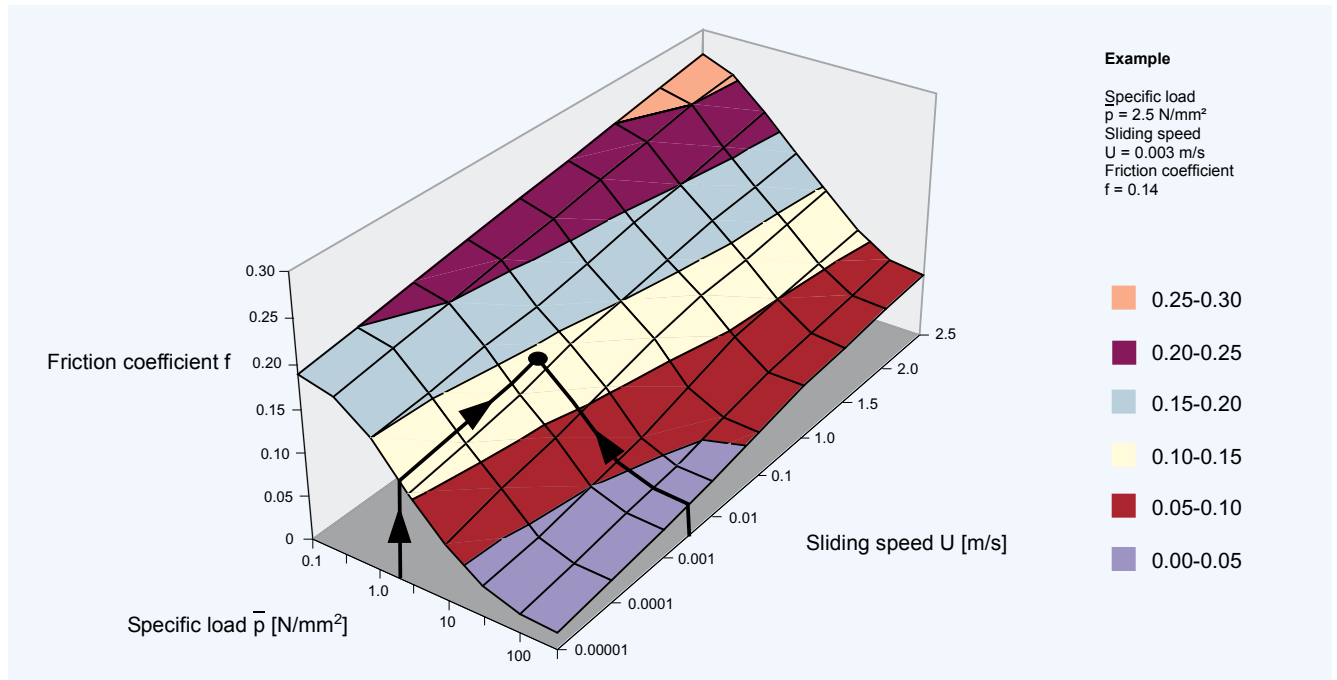

Fig. 9: Variation of friction coefficient f with specific load \bar{p} and sliding speed U at temperature $T = 25 \text{ °C}$

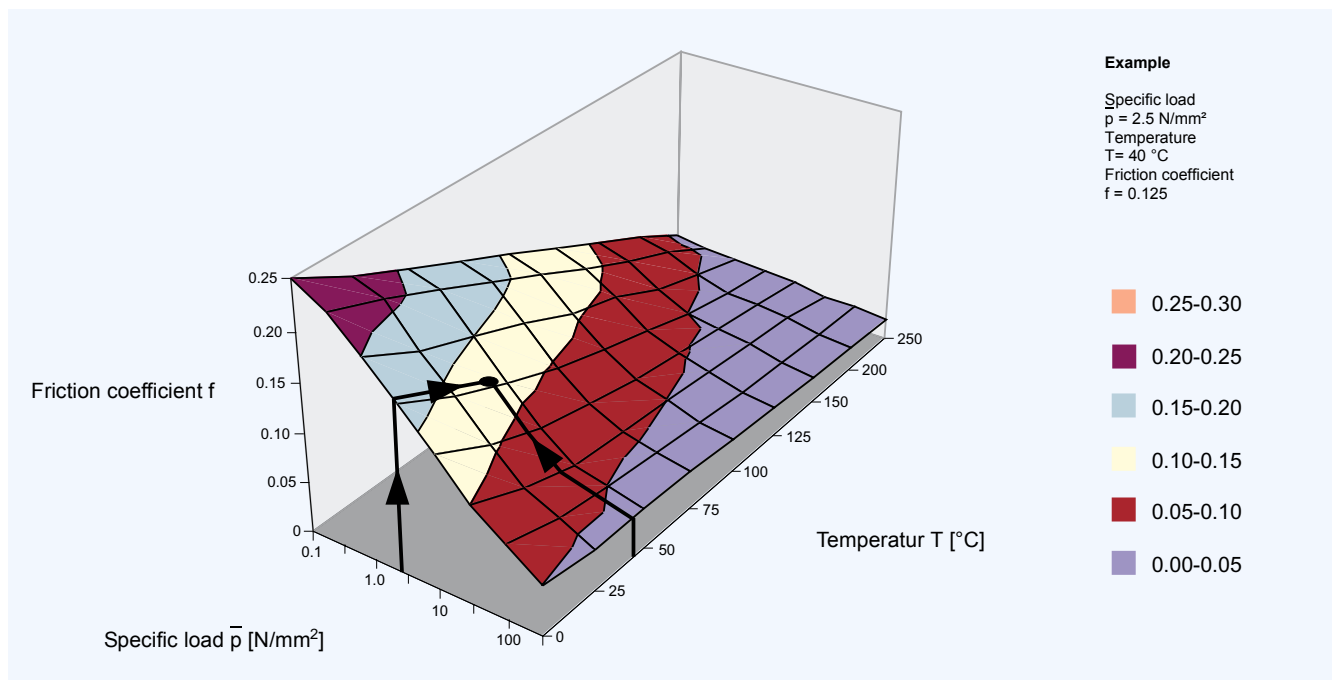

Fig. 10: Variation of friction coefficient f with specific load \bar{p} and temperature T at sliding speed $U = 0.01 \text{ m/s}$

3 Performance

3.1 Design Factors

The main parameters when determining the size or calculating the service life for a DU bearing are:

- Specific Load Limit \bar{p}_{lim}
- $\bar{p}U$ Factor

- Mating surface roughness R_a
- Mating surface material
- Temperature T
- Other environmental factors e.g. housing design, dirt, lubrication

Calculation

Two design procedures are provided as follows:

- A bearing service life calculation based on the permitted bearing dimensions

- A calculation of the necessary bearing dimensions based on the required bearing service life

3.2 Specific Load \bar{p}

For the purpose of assessing bearing performance the specific load \bar{p} is defined as the working load divided by the projected

area of the bearing and is expressed in N/mm^2 .

Cylindrical Bush

(3.2.1) [N/mm²]

$$\bar{p} = \frac{F}{D_i \cdot B}$$

Flanged Bush (Axial Loading)

(3.2.3) [N/mm²]

$$\bar{p} = \frac{F}{0.04 \cdot (D_{fl}^2 - D_i^2)}$$

Thrust Washer

(3.2.2) [N/mm²]

$$\bar{p} = \frac{4F}{\pi \cdot (D_o^2 - D_i^2)}$$

Slideway

(3.2.4) [N/mm²]

$$\bar{p} = \frac{F}{L \cdot W}$$

Permanent deformation of the DU bearing lining may occur at specific loads above $140 N/mm^2$ and under these conditions DU should only be used with slow intermittent movements.

The permissible maximum load on a thrust washer is higher than that on the flange of a flanged bush, and under conditions of high axial loads a thrust washer should be specified.

3.3 Specific Load Limit \bar{p}_{lim}

The maximum load which can be applied to a DU bearing can be expressed in terms of the Specific Load Limit, which depends on the type of the loading. It is highest under steady loads. Conditions of dynamic load or oscillating movement which produce fatigue stress in the bearing result in a reduction in the permissible Specific Load Limit.

In general the specific load on a DU bearing should not exceed the Specific Load Limits given in Table 4.

The values of Specific Load Limit specified in Table 4 assume good alignment between the bearing and mating surface (Fig. 29).

between the bearing and mating surface (Fig. 29).

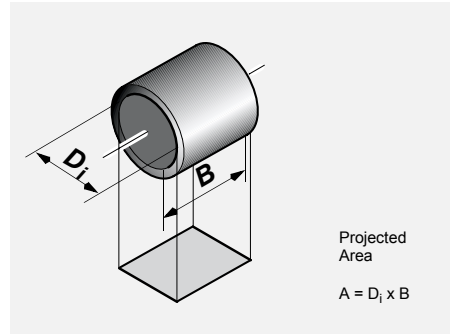

Fig. 11: Projected Area

Maximum specific load \bar{p}_{lim}

Type of loading	\bar{p}_{lim} [N/mm ²]										
steady load, rotating movement	140										
steady load, oscillating movement											
\bar{p}_{lim}	140	140	115	95	85	80	60	44	30	20	
No. of movement cycles Q	1000	2000	4000	6000	8000	10 ⁴	10 ⁵	10 ⁶	10 ⁷	10 ⁸	
dynamic load, rotating or oscillating movement											
\bar{p}_{lim}	60	60	50	46	42	40	30	22	15	10	
No. of load cycles Q	1000	2000	4000	6000	8000	10 ⁴	10 ⁵	10 ⁶	10 ⁷	10 ⁸	

Table 4: Maximum specific load \bar{p}_{lim}

3.4 Sliding Speed U

Speeds in excess of 2.5 m/s sometimes lead to overheating, and a running in procedure may be beneficial.

This could consist of a series of short runs progressively increasing in duration from an initial run of a few seconds.

Calculation of Sliding Speed U [m/s]

Continuous Rotation

Cylindrical Bush

$$(3.4.1) \quad U = \frac{D_i \cdot \pi \cdot N}{60 \cdot 10^3} \quad [\text{m/s}]$$

Thrust Washer

$$(3.4.2) \quad U = \frac{D_o + D_i}{2} \cdot \pi \cdot N \quad [\text{m/s}]$$

Oscillating Movement

Cylindrical Bush

$$(3.4.3) \quad U = \frac{D_i \cdot \pi}{60 \cdot 10^3} \cdot \frac{4\varphi \cdot N_{osz}}{360} \quad [\text{m/s}]$$

Thrust Washer

$$(3.4.4) \quad U = \frac{D_o + D_i}{2} \cdot \pi \cdot \frac{4\varphi \cdot N_{osz}}{360} \quad [\text{m/s}]$$

3 Performance

3.5 $\bar{p}U$ Factor

The useful operating life of a DU bearing is governed by the $\bar{p}U$ factor, the product of the specific load \bar{p} [N/mm²] and the sliding speed U [m/s].

For thrust washers and flanged bush thrust faces the rubbing velocity at the mean diameter is used.

$\bar{p}U$ factors up to 3.6 N/mm² x m/s can be accommodated for short periods, whilst for continuous rating.

$\bar{p}U$ factors up to 1.8 N/mm² x m/s can be used, depending upon the operating life required.

	DU	Unit
\bar{p}	140	N/mm ²
U	2.5	m/s
$\bar{p}U$ continuous	1.8	N/mm ² x m/s
$\bar{p}U$ intermittent	3.6	N/mm ² x m/s

Table 5: Typical data \bar{p} , u and $\bar{p}U$

Calculation of $\bar{p}U$ Factor [N/mm² x m/s]

(3.5.1) [N/mm² x m/s]

$$\bar{p}U = \bar{p} \cdot U$$

3.6 Application Factors

The following factors influence the bearing performance of DU and must be considered in calculating the required dimension

or estimating the bearing life for a particular application.

Temperature

The useful life of a DU bearing depends upon the operating temperature.

Under dry running conditions frictional heat is generated at the rubbing surface of the bearing dependent on the $\bar{p}U$ condition. For a given $\bar{p}U$ factor the operating temperature of the bearing depends upon the temperature of the surrounding environ-

ment and the heat dissipation properties of the housing. Intermittent operation affects the heat dissipation from the assembly and hence the operating temperature of the bearing.

The effect of temperature on the operating life of DU bearings is indicated by the factor a_T shown in Table 6.

Mode of Operation	Nature of housing	Temperature of bearing environment T_{amb} [°C] and Temperature application factor a_T					
		25	60	100	150	200	280
Dry continuous operation	Average heat dissipating qualities	1.0	0.8	0.6	0.4	0.2	0.1
Dry continuous operation	Light pressings or isolated housing with poor heat dissipating qualities	0.5	0.4	0.3	0.2	0.1	-
Dry continuous operation	Non-metallic housings with bad heat dissipating qualities	0.3	0.3	0.2	0.1	-	-
Dry intermittent operation (duration less than 2 min, followed by a longer dwell period)	Average heat dissipating qualities	2.0	1.6	1.2	0.8	0.4	0.2
Continuously immersed in water		2.0	1.5	0.6	-	-	-
Alternately immersed in water & dry		0.2	0.1	-	-	-	-
Continuously immersed in non lubricant liquids other than water		1.5	1.2	0.9	0.6	0.3	0.1
Continuously immersed in lubricant		3.0	2.5	2.0	1.5	-	-

Table 6: Temperature application factor a_T

Mating Surface

The effect of the mating surface material type on the operating life of DU bearings is indicated by the mating surface factor a_M

and the life correction constant a_L shown in Table 7.

Material	a_M	a_L
Steel and Cast Iron		
Carbon Steel	1	200
Carbon Manganese Steel	1	200
Alloy Steel	1	200
Case Hardened Steel	1	200
Nitrided Steel	1	200
Salt bath nitrocarburised	1	200
Stainless Steel (7-10 % Ni, 17-20 % Cr)	2	200
Sprayed Stainless Steel	1	200
Cast Iron(0.3 μm R_a)	1	200
Plated Steel with minimum thickness of plating 0.013 mm		
Cadmium	0.2	600
Material		
Hard Chrome	2.0	600
Lead	1.5	600
Nickel	0.2	600
Phosphated	0.2	300
Tin Nickel	1.2	600
Titanium Nitride	1.0	600
Tungsten Carbide Flame Plated	3.0	600
Zinc	0.2	600
Non ferrous metals		
Aluminium Alloys	0.4	200
Bronze and Copper Base Alloys	0.1-0.4	200
Hard Anodised Aluminium (0.025 mm thick)	3.0	600

Table 7: Mating surface factor a_M and life correction constant a_L

Note:

The factor values given assume a mating surface finish of $\leq 0.4 \mu\text{m} R_a$

- A ground surface is preferred to fine turned
- Surfaces should be cleaned of abrasive particles after polishing
- Cast iron surfaces should be ground to $< 0.3 \text{ mm } R_a$
- The grinding cut should be in the same direction as the bearing motion relative to the shaft

Bearing Size

The running clearance of a DU bearing increases with bearing diameter resulting in a proportionally smaller contact area between the shaft and bearing. This reduction in contact area has the effect of increasing the actual unit load and hence p_U

factor. The bearing size factor (Fig. 13) is used in the design calculations to allow for this effect. The bearing size factor is also applicable to thrust washers, where for other reasons, bearing diameter has an effect on performance.

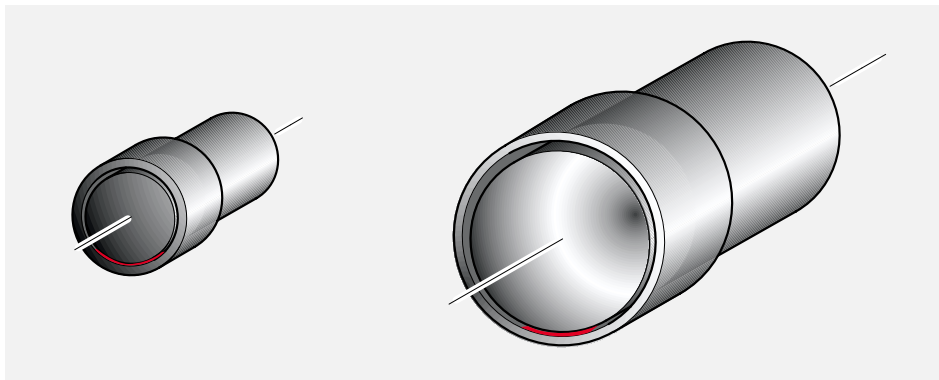

Fig. 12: Contact area between bearing and shaft.

3 Performance

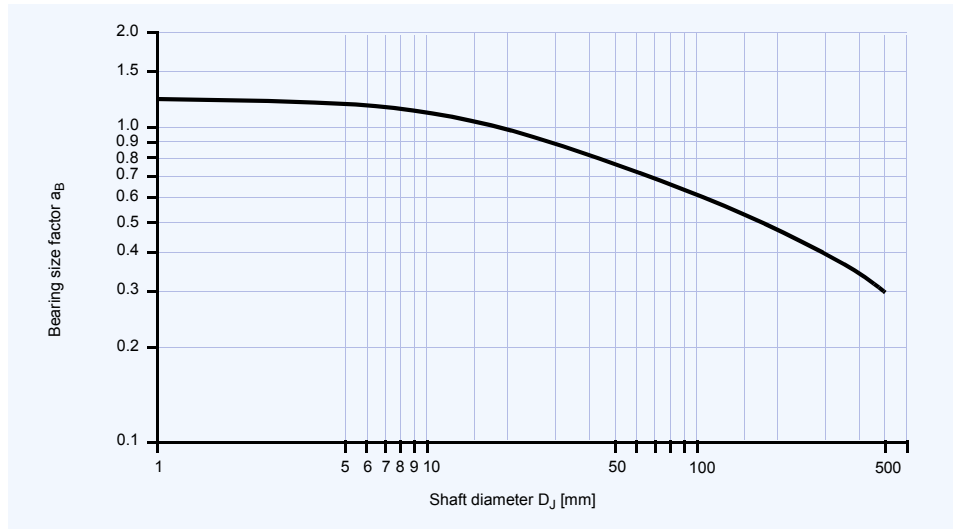

Fig. 13: Bearing size factor a_B

Bore Burnishing

Burnishing or machining the bore of a DU bearing results in a reduction in the wear performance. The application factor a_C given in Table 8 is used in the design calculations to allow for this effect.

Degree of sizing		Application factor a_C
Burnishing: Excess of burnishing tool diameter over mean bore size	0.025 mm	0.8
	0.038 mm	0.6
	0.050 mm	0.3
Boring: Depth of cut	0.025 mm	0.6
	0.038 mm	0.3
	0.050 mm	0.1

Table 8: Bore burnishing or machining application factor a_C

Type of Load

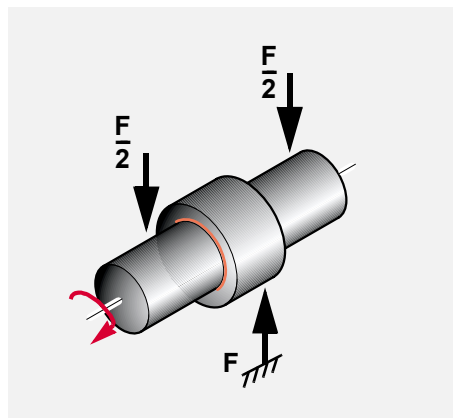

Fig. 14: Steady load, Bush Stationary, Shaft rotating

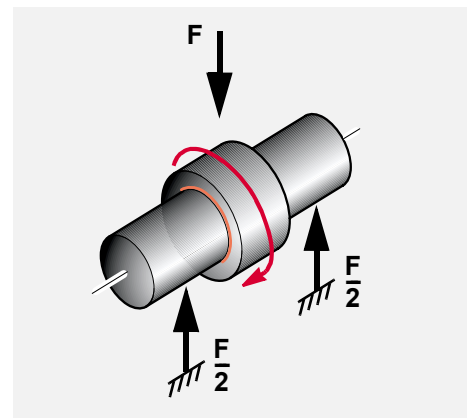

Fig. 15: Rotating load, shaft stationary, bush rotating

3.7 Calculation of Bearing Size

In designing all bearings, the shaft diameter is usually determined by considerations of physical stability or stiffness and the main variable to be determined is the length of the bush or the land width of the thrust washer.

The formulae given below enable designers to calculate the length or width

necessary to satisfy both the Specific Load Limit and the $\bar{p}U$ /Life relationship.

If it is found that the total length exceeds twice the diameter of the shaft, this indicates that the conditions envisaged are too severe for DU material and consideration should be given to repositioning the bearings in order to reduce the load.

Calculation for Bushes

Bush Stationary, Shaft Rotating

$$(3.7.1) \quad B = \frac{F \cdot N \cdot (L_H + a_L)}{1.25 \cdot 10^7 \cdot a_T \cdot a_M \cdot a_B} + \frac{F}{\bar{p}_{lim} \cdot D_i} \quad [\text{mm}]$$

Bush Rotating, Shaft Stationary

$$(3.7.2) \quad B = \frac{F \cdot N \cdot (L_H + a_L)}{2.5 \cdot 10^7 \cdot a_T \cdot a_M \cdot a_B} + \frac{F}{\bar{p}_{lim} \cdot D_i} \quad [\text{mm}]$$

Calculation for Thrust Washers

$$(3.7.3) \quad D_o - D_i = \frac{F \cdot N \cdot (L_H + a_L)}{1.25 \cdot 10^7 \cdot a_T \cdot a_M \cdot a_B} + \sqrt{D_i^2 + \frac{1.3F}{\bar{p}_{lim}}} - D_i \quad [\text{mm}]$$

Calculation for Slideways

$$(3.7.4) \quad A = \frac{2.38 \cdot F \cdot U(L_H + a_L)}{10^3 \cdot a_T \cdot a_M} \cdot \frac{(L + L_S)}{L} + \frac{F}{\bar{p}_{lim}} \quad [\text{mm}^2]$$

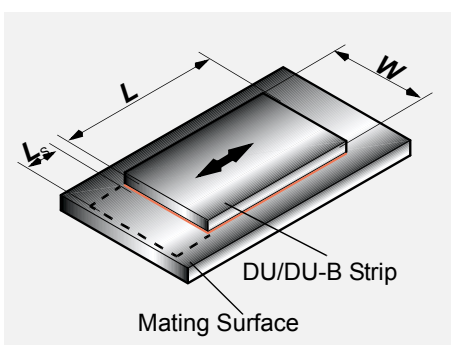

Fig. 16: Slideway

3.8 Calculation of Bearing Service Life

Where the size of a bearing is governed largely by the space available the following calculation can be used to determine whether

its useful life will satisfy the requirements. If the calculated life is inadequate, a larger bearing should be considered.

Specific load \bar{p}

Bushes

$$(3.8.1) \quad \bar{p} = \frac{F}{D_i \cdot B} \quad [\text{N/mm}^2]$$

Thrust Washers

$$(3.8.3) \quad \bar{p} = \frac{4F}{\bar{p} \cdot (D_o^2 - D_i^2)} \quad [\text{N/mm}^2]$$

Flanged Bushes

$$(3.8.2) \quad \bar{p} = \frac{F}{0.04 \cdot (D_{fl}^2 - D_i^2)} \quad [\text{N/mm}^2]$$

High load factor a_E

$$(3.8.4) \quad a_E = \frac{\bar{p}_{lim} - \bar{p}}{\bar{p}_{lim}} \quad [-]$$

\bar{p}_{lim} see Table 4, Page 13

If a_E is negative then the bearing is overloaded. Increase the bearing diameter and/or length.

Modified $\bar{p}U$ Factor

Bushes

$$(3.8.5) \quad \bar{p}U = \frac{5.25 \cdot 10^{-5} F \cdot N}{a_E \cdot B \cdot a_T \cdot a_M \cdot a_B} \quad [\text{N/mm}^2 \times \text{m/s}]$$

Thrust Washers

$$(3.8.7) \quad \bar{p}U = \frac{3.34 \cdot 10^{-5} F \cdot N}{a_E \cdot (D_o - D_i) \cdot a_T \cdot a_M \cdot a_B} \quad [\text{N/mm}^2 \times \text{m/s}]$$

Flanged Bushes

$$(3.8.6) \quad \bar{p}U = \frac{6.5 \cdot 10^{-4} F \cdot N}{a_E \cdot (D_{fl} - D_i) \cdot a_T \cdot a_M \cdot a_B} \quad [\text{N/mm}^2 \times \text{m/s}]$$

For oscillating movement, calculate the average rotational speed.

$$(3.8.8) \quad N = \frac{4\varphi \cdot N_{osz}}{360} \quad [1/\text{min}]$$

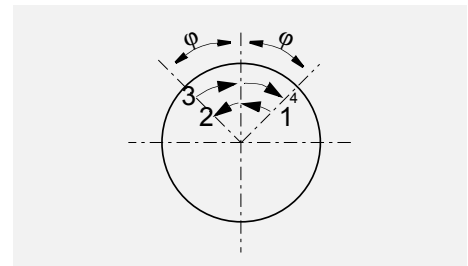

Fig. 17: Oscillating cycle φ

Estimation of bearing life L_H **Bushes (Steady load)**

$$(3.8.9) \quad L_H = \frac{615}{\bar{p}U} - a_L \quad [h]$$

Βυσηες (Rotating load)

$$(3.8.10) \quad L_H = \frac{1230}{\bar{p}U} - a_L \quad [h]$$

Bore Burnishing

If the DU bush is bore burnished then this must be allowed for in estimating the bea-

Φλανγηδ Βυσηες (Axial load)

$$(3.8.11) \quad L_H = \frac{410}{\bar{p}U} - a_L \quad [h]$$

Τηρυστ Ωασηερσ

$$(3.8.12) \quad L_H = \frac{410}{\bar{p}U} - a_L \quad [h]$$

ring life by the application factor a_C (Table 8, Page 16).

Estimated Bearing Life

$$(3.8.13) \quad L_H = L_H \cdot a_C \quad [h]$$

Slideways**Specific load factor**

$$(3.8.14) \quad a_{E1} = A - \frac{F}{\bar{p}_{lim}} \quad [-]$$

If negative the bearing is overloaded and the bearing area should be increased.

Speed temperature and material application factors

$$(3.8.15) \quad a_{E2} = \frac{420 \cdot a_T \cdot a_M}{F \cdot U} \quad [-]$$

Relative contact area factor

$$(3.8.16) \quad a_{E3} = \frac{A}{A_M} \quad [-]$$

Estimated bearing life

$$(3.8.17) \quad L_H = a_{E1} \cdot a_{E2} \cdot a_{E3} - a_L \quad [h]$$

Estimated bearing lives greater than 4000 h are subject to error due to inaccuracies in the extrapolation of test data.

$Z_T = L_H \times N_{osz} \times 60$ (for Oscillating Movements) (3.8.18).

$Z_T = L_H \times C \times 60$ (for dynamic load) (3.8.19).

Check that Z_T is less than total number of cycles Q for the operating specific load \bar{p} (Table 4, Page 13).

For Oscillating Movements or Dynamic load: Calculate estimated number of cycles Z_T .

If $Z_T < Q$, L_H will be limited by wear after Z_T cycles.

If $Z_T > Q$, L_H will be limited by fatigue after Z_T cycles.

3 Performance

3.9 Worked Examples

Cylindrical Bush

Given:			
Load Details	Steady Load	Inside Diameter D_i	40 mm
	Continuous Rotation	Length B	30 mm
Shaft	Steel	Bearing Load F	5000 N
	Unlubricated at 25 °C	Rotational Speed N	50 1/min

Calculation Constants and Application Factors		
Specific Load Limit p_{lim}	140 N/mm ²	(Table 4, Page 13)
Temperature Application Factor a_T	1.0	(Table 6, Page 14)
Material Application Factor a_M	1.0	(Table 7, Page 15)
Bearing Size Factor a_B	0.85	(Fig. 13, Page 16)
Life Correction Constant a_L	200	(Table 7, Page 15)

Calculation	Ref	Value
Specific Load \bar{p} [N/mm ²]	(3.2.1), Page 12	$\bar{p} = \frac{F}{D_i \cdot B} = \frac{5000}{40 \cdot 30} = 4.17$
Sliding Speed U [m/s]	(3.4.1), Page 13	$U = \frac{D_i \cdot \pi \cdot N}{60 \cdot 10^3} = \frac{40 \cdot 3.14 \cdot 50}{60 \cdot 10^3} = 0.105$
pU Factor (Calculate from Table 5, Page 14)	(3.5.1), Page 14	$\bar{p}U = \bar{p} \cdot U = 4.17 \cdot 0.105 = 0.438$
High Load Factor a_E [-] (must be >0)	(3.8.4), Page 18	$a_E = \frac{\bar{p}_{lim} - \bar{p}}{\bar{p}_{lim}} = \frac{140 - 4.17}{140} = 0.97$
Modified pU Factor [N/mm ² x m/s]	(3.8.5), Page 18	$\bar{p}U = \frac{5.25 \cdot 10^{-5} F \cdot N}{a_E \cdot B \cdot a_T \cdot a_M \cdot a_B} = 0.53$
Life L_H [h]	(3.8.9), Page 19	$L_H = \frac{615}{\bar{p}U} - a_L = \frac{615}{0.53} - 200 = 960$

Cylindrical Bush

Given:			
Load Details	Dynamic Load	Inside Diameter D_i	30 mm
	Continuous Rotation	Length B	30 mm
Shaft	Steel	Bearing Load F	25000 N
	Unlubricated at 25 °C	Rotational Speed N	15 1/min
		Load frequency	

Calculation Constants and Application Factors		
Specific Load Limit p_{lim}	60 N/mm ²	(Table 4, Page 13)
Temperature Application Factor a_T	1.0	(Table 6, Page 14)
Material Application Factor a_M	1.0	(Table 7, Page 15)
Bearing Size Factor a_B	1	(Fig. 13, Page 16)
Life Correction Constant a_L	200	(Table 7, Page 15)

Calculation	Ref	Value
Specific Load \bar{p} [N/mm ²]	(3.2.1), Page 12	$\bar{p} = \frac{F}{D_i \cdot B} = \frac{25000}{30 \cdot 30} = 27.78$
Sliding Speed U [m/s]	(3.4.1), Page 13	$U = \frac{D_i \cdot \pi \cdot N}{60 \cdot 10^3} = \frac{30 \cdot 3.14 \cdot 15}{60 \cdot 10^3} = 0.024$
pU Factor (Calculate from Table 5, Page 14)	(3.5.1), Page 14	$\bar{p}U = \bar{p} \cdot U = 27.78 \cdot 0.024 = 0.669$
High Load Factor a_E [-] (must be >0)	(3.8.4), Page 18	$a_E = \frac{\bar{p}_{lim} - \bar{p}}{\bar{p}_{lim}} = \frac{60 - 27.78}{60} = 0.54$
Modified pU Factor [N/mm ² x m/s]	(3.8.5), Page 18	$\bar{p}U = \frac{5.25 \cdot 10^{-5} F \cdot N}{a_E \cdot B \cdot a_T \cdot a_M \cdot a_B} = 1.23$
Life L_H [h]	(3.8.9), Page 19	$L_H = \frac{615}{\bar{p}U} - a_L = \frac{615}{1.23} - 200 = 350$
Calculate total load cycles	Table 4, Page 13	$Z_T = 300 \cdot 60 \cdot 60 = 300 \cdot 10^6$ Q for 27.78 N/mm ² = bearing will fatigue after 10 ⁵ cycles (= 28 h)

Cylindrical Bush

Given:			
Load Details	Steady Load	Inside Diameter D_i	50 mm
	Load Rotating	Length B	50 mm
	Continuous Rotation		
Shaft	Steel	Bearing Load F	10000 N
	Unlubricated at 100 °C	Rotational Speed N	50 1/min

Calculation Constants and Application Factors		
Specific Load Limit p_{lim}	60 N/mm ²	(Table 4, Page 13)
Temperature Application Factor a_T	0.6	(Table 6, Page 14)
Material Application Factor a_M	1.0	(Table 7, Page 15)
Bearing Size Factor a_B	0.78	(Fig. 13, Page 16)
Life Correction Constant a_L	200	(Table 7, Page 15)

Calculation	Ref	Value
Specific Load \bar{p} [N/mm ²]	(3.2.1), Page 12	$\bar{p} = \frac{F}{D_i \cdot B} = \frac{10000}{50 \cdot 50} = 4.0$
Sliding Speed U [m/s]	(3.4.1), Page 13	$U = \frac{D_i \cdot \pi \cdot N}{60 \cdot 10^3} = \frac{50 \cdot 3.14 \cdot 50}{60 \cdot 10^3} = 0.131$
pU Factor (Calculate from Table 5, Page 14)	(3.5.1), Page 14	$\bar{p}U = \bar{p} \cdot U = 4.0 \cdot 0.131 = 0.524$
High Load Factor a_E [-] (must be >0)	(3.8.4), Page 18	$a_E = \frac{\bar{p}_{lim} - \bar{p}}{\bar{p}_{lim}} = \frac{60 - 4.0}{60} = 0.93$
Modified pU Factor [N/mm ² x m/s]	(3.8.5), Page 18	$\bar{p}U = \frac{5.25 \cdot 10^{-5} F \cdot N}{a_E \cdot B \cdot a_T \cdot a_M \cdot a_B} = 1.20$
Life L_H [h]	(3.8.9), Page 19	$L_H = \frac{1230}{\bar{p}U} - a_L = \frac{1230}{1.2} - 200 = 825$

Cylindrical Bush

Given:			
Load Details	Steady Load	Inside Diameter D_i	45 mm
	Oscillating Movements	Length B	40 mm
Shaft	Stainless Steel	Bearing Load F	40000 N
	Unlubricated at 25 °C	Frequency C	150
	Continuous operation	Amplitudes Φ	20 °

Calculation Constants and Application Factors		
Specific Load Limit p_{lim}	140 N/mm ²	(Table 4, Page 13)
Temperature Application Factor a_T	1.0	(Table 6, Page 14)
Material Application Factor a_M	2.0	(Table 7, Page 15)
Bearing Size Factor a_B	0.81	(Fig. 13, Page 16)
Life Correction Constant a_L	200	(Table 7, Page 15)

Calculation	Ref	Value
Specific Load \bar{p} [N/mm ²]	(3.2.1), Page 12	$\bar{p} = \frac{F}{D_i \cdot B} = \frac{40000}{45 \cdot 40} = 22.22$
Sliding Speed U [m/s]	(3.4.1), Page 13	$U = \frac{45 \cdot 3.14 \cdot 33.33}{60 \cdot 10^3} = 0.078$
Average speed N [1/min]	(3.8.8), Page 18	$N = \frac{4\phi \cdot N_{osz}}{360} = \frac{4 \cdot 20 \cdot 150}{360} = 33.33$
pU Factor (Calculate from Table 5, Page 14)	(3.5.1), Page 14	$\bar{p}U = \bar{p} \cdot U = 22.22 \cdot 0.078 = 1.733$
High Load Factor a_E [-] (must be >0)	(3.8.4), Page 18	$a_E = \frac{\bar{p}_{lim} - \bar{p}}{\bar{p}_{lim}} = \frac{140 - 22.22}{140} = 0.84$
Modified pU Factor [N/mm ² x m/s]	(3.8.5), Page 18	$\bar{p}U = \frac{5.25 \cdot 10^{-5} F \cdot N}{a_E \cdot B \cdot a_T \cdot a_M \cdot a_B} = 1.29$
Life L_H [h]	(3.8.9), Page 19	$L_H = \frac{615}{\bar{p}U} - a_L = \frac{615}{1.29} - 200 = 277$
Calculate total load cycles	Table 4, Page 13	$Z_T = 277 \cdot 150 \cdot 60 = 2.5 \cdot 10^6$ Q for 22.22 N/mm ² = 10 ⁸ bearing o.k.!

Thrust Washer

Given:			
Load Details	Axial Load,	Outside Diameter D_o	62 mm
	Continuous Rotation	Inside Diameter D_i	38 mm
Shaft	Steel	Bearing Load F	6500 N
	Unlubricated at 25 °C	Rotational Speed N	60 1/min

Calculation Constants and Application Factors		
Specific Load Limit p_{lim}	140 N/mm ²	(Table 4, Page 13)
Temperature Application Factor a_T	1.0	(Table 6, Page 14)
Material Application Factor a_M	1.0	(Table 7, Page 15)
Bearing Size Factor a_B	0.85	(Fig. 13, Page 16)
Life Correction Constant a_L	200	(Table 7, Page 15)

Calculation	Ref	Value
Specific Load \bar{p} [N/mm ²]	(3.8.3), Page 18	$\bar{p} = \frac{4 \cdot 6500}{3 \cdot 14 \cdot (62^2 - 38^2)} = 3.45$
Sliding Speed U [m/s]	(3.4.2), Page 13	$U = \frac{(62+38) \cdot 3 \cdot 14 \cdot 60}{2 \cdot 60 \cdot 1000} = 0.157$
pU Factor (Calculate from Table 5, Page 14)	(3.5.1), Page 14	$\bar{p}U = \bar{p} \cdot U = 3.45 \cdot 0.157 = 0.541$
High Load Factor a_E [-]	(3.8.4), Page 18	$a_E = \frac{140 - 3.45}{140} = 0.98$
Modified pU Factor [N/mm ² x m/s]	(3.8.7), Page 18	$\bar{p}U = \frac{3.34 \cdot 10^{-5} \cdot 6500 \cdot 60}{0.87 \cdot (62 - 38) \cdot 1 \cdot 1 \cdot 0.85} = 0.65$
Life L_H [h]	(3.8.12), Page 19	$L_H = \frac{410}{0.65} - 200 = 431$

Flanged Bush

Given:			
Load Details	Axial Load	Flange outside Diameter D_{fl}	23 mm
	Continuous Rotation	Inside Diameter D_i	15 mm
Shaft	Steel	Bearing Load F	250 N
	Unlubricated at 25 °C	Rotational Speed N	25 1/min

Calculation Constants and Application Factors		
Specific Load Limit p_{lim}	140 N/mm ²	(Table 4, Page 13)
Temperature Application Factor a_T	1.0	(Table 6, Page 14)
Material Application Factor a_M	1.0	(Table 7, Page 15)
Bearing Size Factor a_B	1.0	(Fig. 13, Page 16)
Life Correction Constant a_L	200	(Table 7, Page 15)

Calculation	Ref	Value
Specific Load \bar{p} [N/mm ²]	(3.2.2), Page 12	$\bar{p} = \frac{250}{0.04 \cdot (23^2 - 15^2)} = 20.55$
Sliding Speed U [m/s]	(3.4.2), Page 13	$U = \frac{(23+15) \cdot 3 \cdot 14 \cdot 25}{2 \cdot 60 \cdot 1000} = 0.025$
pU Factor (Calculate from Table 5, Page 14)	(3.5.1), Page 14	$\bar{p}U = \bar{p} \cdot U = 20.55 \cdot 0.025 = 0.513$
High Load Factor a_E [-]	(3.8.4), Page 18	$a_E = \frac{140 - 20.55}{140} = 0.85$
Modified pU Factor [N/mm ² x m/s]	(3.8.6), Page 18	$\bar{p}U = \frac{6.5 \cdot 10^{-5} \cdot 250 \cdot 50}{0.85 \cdot (23 - 15) \cdot 1 \cdot 1 \cdot 1} = 0.59$
Life L_H [h]	(3.8.11), Page 19	$L_H = \frac{410}{0.59} - 200 = 495$

4 Data Sheet

4 Data Sheet Application: _____

4.1 Data for bearing design calculations

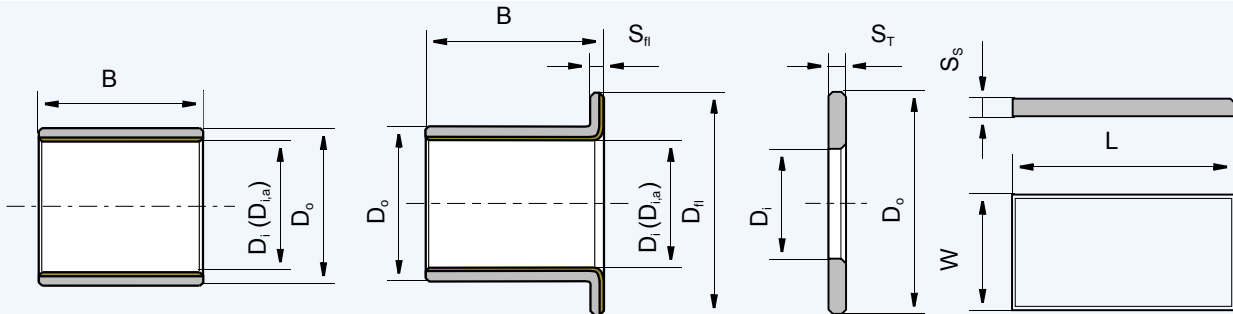

Cylindrical Bush
 Flanged Bush
 Thrust Washer
 Slideplate
 Special (Sketch)

Rotational movement
 Steady load
 Rotating load
 Oscillating movement
 Linear movement

Existing Design
 New Design

Quantity

Dimensions in mm

Inside Diameter D_i

Outside Diameter D_o

Length B

Flange Diameter D_f

Flange Thickness S_f

Length of slideplate L

Width of slideplate W

Thickness of slideplate S_s

Load

Radial load or specific load F [N]
 \bar{p} [N/mm²]

Axial load or specific load F [N]
 \bar{p} [N/mm²]

Movement

Rotational speed N [1/min]

Speed U [m/s]

Length of Stroke L_s [mm]

Frequency of Stroke [1/min]

Oscillating cycle φ [°]

Oscillating frequency N_{osz} [1/min]

Service hours per day

Continuous operation

Intermittent operation

Operating time

Days per year

Fits and Tolerances

Shaft D_J

Bearing Housing D_H

Operating Environment

Ambient temperature T_{amb} [°]

Housing with good heat transfer properties

Light pressing or insulated housing which poor heat transfer properties

Non metal housing with poor heat transfer properties

Alternate operation in water and dry

Mating surface

Material

Hardness HB/HRC

Surface finish R_a [μm]

Lubrication

Dry

Continuous lubrication

Process fluid lubrication

Initial lubrication only

Hydrodynamic conditions

Process Fluid

Lubricant

Dynamic viscosity η

Service life

Required service life L_H [h]

Customer Data

Company: _____ City: _____

Street: _____ Post Code: _____

Project:

Name: _____

Tel.: _____

Date:

Signature: _____

Fax: _____

5 Lubrication

Although DU was developed as a dry self lubricating bearing material, DU also provides excellent performance in lubricated applications.

5.1 Lubricants

DU can be used with most fluids including

- water
- lubricating oils
- engine oil
- turbine oil
- hydraulic fluid
- solvent
- refrigerants

In general, the fluid will be acceptable if it does not chemically attack the PTFE/lead overlay or the porous bronze interlayer. Where there is doubt about the suitability of a fluid, a simple test is to submerge a

The following sections describe the basics of lubrication and provide guidance on the application of DU in such environments.

sample of DU material in the fluid for two to three weeks at 15-20 °C above the operating temperature.

The following will usually indicate that the fluid is not suitable for use with DU:

- A significant change in the thickness of the DU material,
- A visible change in the bearing surface other than some discolouration or staining
- A visible change in the microstructure of the bronze interlayer

5.2 Tribology

There are three modes of lubricated bearing operation which relate to the thickness of the developed lubricant film between the bearing and the mating surface.

These three modes of operation depend upon:

- Bearing dimensions
- Clearance
- Load
- Speed
- Lubricant Viscosity
- Lubricant Flow

Hydrodynamic lubrication

Characterised by:

- Complete separation of the shaft from the bearing by the lubricant film
- Very low friction and no wear of the bearing or shaft since there is no contact.
- Coefficients of friction of 0.001 to 0.01

Hydrodynamic conditions occur when

$$(5.2.1) \quad \bar{p} \leq \frac{U \cdot \eta}{7.5} \cdot \frac{B}{D_i} \quad [\text{N/mm}^2]$$

$$\bar{p} \leq \frac{U \cdot \eta}{7.5} \cdot \frac{B}{D_i}$$

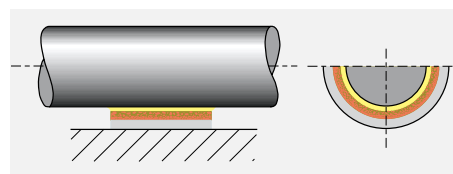

Fig. 18: Hydrodynamic lubrication

Mixed film lubrication

Characterised by:

- Combination of hydrodynamic and boundary lubrication.
- Part of the load is carried by localised areas of self pressurised lubricant and the remainder supported by boundary lubrication.
- Friction and wear depend upon the degree of hydrodynamic support developed.

- DU provides low friction and high wear resistance to support the boundary lubricated element of the load.

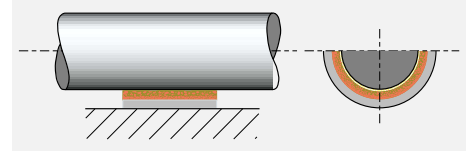

Fig. 19: Mixed film lubrication

Boundary lubrication

Characterised by:

- Rubbing of the shaft against the bearing with virtually no lubricant separating the two surfaces.
- Bearing material selection is critical to performance
- Shaft wear is likely due to contact between bearing and shaft.
- The excellent self lubricating properties of DU material minimises wear under these conditions.

- The coefficient of friction with DU is typically 0.02 to 0.06 under boundary lubrication conditions.

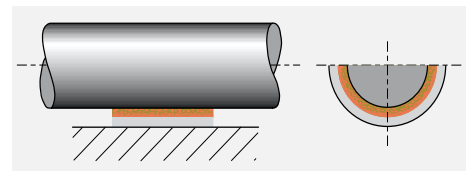

Fig. 20: Boundary lubrication

5.3 Characteristics of Lubricated DU bearings

DU is particularly effective in the most demanding of lubricated applications

where full hydrodynamic operation cannot be maintained, for example:

- **High load conditions**
In highly loaded applications operating under boundary or mixed film conditions DU shows excellent wear resistance and low friction.
- **Start up and shut down under load**
With insufficient speed to generate a hydrodynamic film the bearing will operate under boundary or mixed film conditions. DU minimises wear and requires less start up torque than conventional metallic bearings.
- **Sparse lubrication**
Many applications require the bearing to operate with less than the ideal lubricant

- supply, typically with splash or mist lubrication only. DU provides excellent self lubricating properties.
- **Non lubricating fluids**
DU operates satisfactorily in low viscosity and non lubricating fluids such as water and some process fluids.
Note the following however:
If a DU bearing is required to run dry after running in water under non hydrodynamic conditions then the wear resistance will be substantially reduced due to an increased amount of bedding in wear.

5.4 Design Guidance for Lubricated Applications

Fig. 21 shows the three lubrication regimes discussed above. In order to use Fig. 21, using the formula on page 12 and page 13:

- Calculate the specific load \bar{p} ,
- Calculate the shaft surface speed U.

Using the viscosity temperature relationships presented in Table 9.

- Determine the lubricant viscosity in centipoise, of the lubricant.

If the operating temperature of the fluid is unknown, a provisional temperature of 25 °C above ambient can be used.

Area 1

The bearing will operate with boundary lubrication and $\bar{p}U$ factor will be the major determinant of bearing life. DU bearing performance can be calculated using the

method given in Section 3, although the result will probably underestimate the bearing life

Area 2

The bearing will operate with mixed film lubrication and $\bar{p}U$ factor is no longer a significant parameter in determining the

bearing life. DU bearing performance will depend upon the nature of the fluid and the actual service conditions.

Area 3

The bearing will operate with hydrodynamic lubrication. Bearing wear will be determined only by the cleanliness of the

lubricant and the frequency of start up and shut down.

Area 4

These are the most demanding operating conditions. The bearing is operated under either high speed or high bearing load to viscosity ratio, or, a combination of both.

- excessive operating temperature and/or
- high wear rate .

Bearing performance may be improved by the addition of one or more grooves to the bearing and a shaft surface finish $<0,05 \mu\text{m } R_a$.

These conditions may cause:

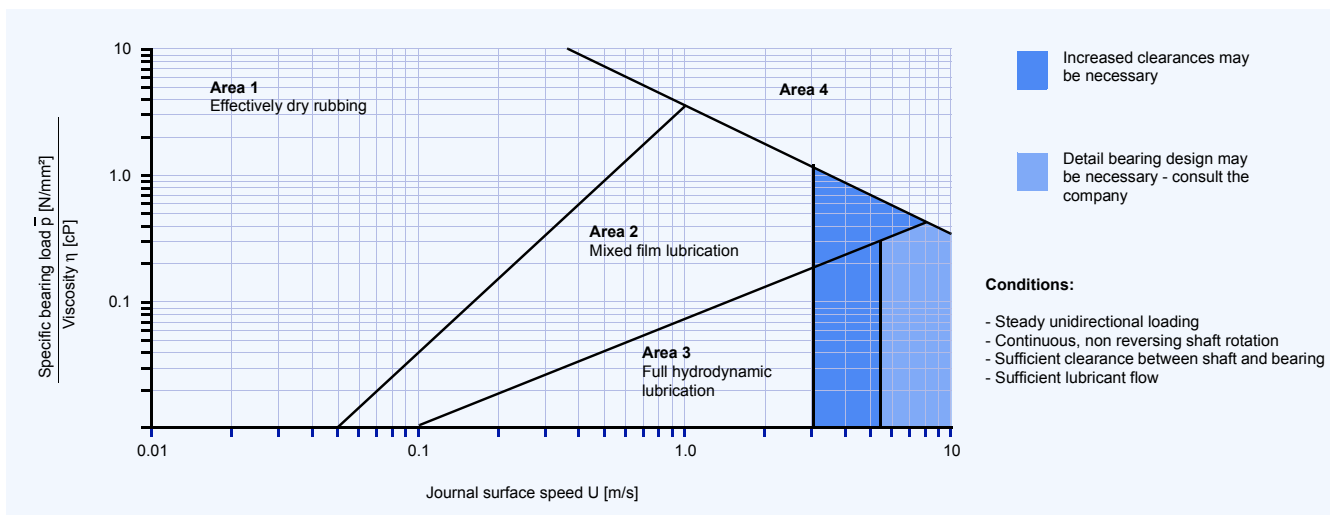

Fig. 21: Design guide for lubricated application

Temperature [°C]	Viscosity cP														
	0	10	20	30	40	50	60	70	80	90	100	110	120	130	140
Lubricant															
ISO VG 32	310	146	77	44	27	18	13	9.3	7.0	5.5	4.4	3.6	3.0	2.5	2.2
ISO VG 46	570	247	121	67	40	25	17	12	9.0	6.9	5.4	4.4	3.6	3.0	2.6
ISO VG 68	940	395	190	102	59	37	24	17	12	9.3	7.2	5.8	4.7	3.9	3.3
ISO VG 100	2110	780	335	164	89	52	33	22	15	11.3	8.6	6.7	5.3	4.3	3.6
ISO VG 150	3600	1290	540	255	134	77	48	31	21	15	11	8.8	7.0	5.6	4.6
Diesel oil	4.6	4.0	3.4	3.0	2.6	2.3	2.0	1.7	1.4	1.1	0.95				
Petrol	0.6	0.56	0.52	0.48	0.44	0.40	0.36	0.33	0.31						
Kerosene	2.0	1.7	1.5	1.3	1.1	0.95	0.85	0.75	0.65	0.60	0.55				
Water	1.79	1.30	1.0	0.84	0.69	0.55	0.48	0.41	0.34	0.32	0.28				

Table 9: Viscosity data

5 Lubrication

5.5 Clearances for lubricated operation

The recommended shaft and housing diameters given for standard DU bushes will provide sufficient clearance for applications operating with boundary lubrication. For bearings operating with mixed film or hydrodynamic lubrication it may be neces-

sary to improve the fluid flow through the bearing by reducing the recommended shaft diameter by approximately 0.1 %, particularly when the shaft surface speed exceeds 2.5 m/s.

5.6 Mating Surface Finish for lubricated operation

- R_a £0.4 mm Boundary lubrication
- $R_a = 0.1-0.2$ mm Mixed film or hydrodynamic conditions
- R_a £0.05 μ m for the most demanding operating conditions

5.7 Grooving for lubricated operation

In demanding applications an axial oil groove will improve the performance of DU. Fig. 22 shows the recommended form and location of a single groove with

respect to the applied load and the bearing split. Glacier Garlock Bearings can manufacture special DU bearings with embossed or milled grooves on request.

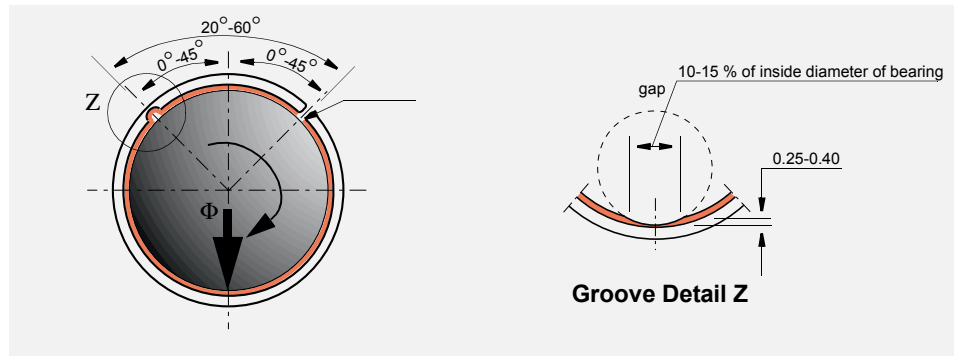

Fig. 22: Location of oil holes and grooves

5.8 Grease Lubrication

DU is not generally recommended for use with grease lubrication.

In particular the following must be avoided:

- Dynamic loads - which can result in ero-

- Greases with EP additives or fillers such as graphite or MoS_2 which can cause rapid wear of DU.

6 Bearing Assembly

Dimensions and Tolerances

DU bushes are prefinished in the bore, and except in very exceptional circumstances, must not be burnished, broached or otherwise modified. It is essential that the correct running clearance is used and that both the diameter of the shaft and the bore of the housing are finished to the limits given in the tables. Under dry running conditions any increase in the clearances given will result in a proportional reduction in performance.

If the bearing housing is unusually flexible the bush will not close in by the calculated

amount and the running clearance will be more than the optimum. In these circumstances the housing should be bored slightly undersize or the journal diameter increased, the correct size being determined by experiment.

Where free running is essential, or where light loads (less than 0.1 N/mm²) prevail and the available torque is low, increased clearance is required and it is recommended that the shaft size quoted in the table be reduced by 0.025 mm.

6.1 Allowance for Thermal Expansion

For operation in high temperature environments the clearance should be increased by the amounts indicated by Fig. 24 to

compensate for the inward thermal expansion of the bearing lining.

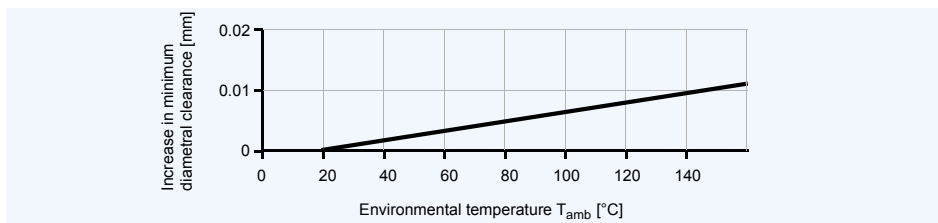

Fig. 23: Increase in diametral clearance

If the housing is non-ferrous then the bore should be reduced by the amounts given in Table 10, in order to give an increased

interference fit to the bush, with a similar reduction in the journal diameter additional to that indicated by Fig. 23.

Housing material	Reduction in housing diameter per 100 °C rise	Reduction in shaft diameter per 100 °C rise
Aluminium alloys	0.1 %	0.1 % + values from Fig. 23
Copper base alloys	0.05 %	0.05 % + values from Fig. 23
Steel and cast iron	–	values from Fig. 23
Zinc base alloys	0.15 %	0.15 % + values from Fig. 23

Table 10: Allowance for high temperature

6.2 Tolerances for minimum clearance

Where it is required to keep the variation of assembled clearance to a minimum, closer tolerances can be specified towards the upper end of the journal tolerance and the lower end of the housing tolerance.

If housings to H6 tolerance are used, then the journals should be finished to the following limits.

The sizes in Table 11 give the following nominal clearance range.

D_i	D_j
<25 mm	-0.019
	-0.029
>25 mm < 50 mm	-0.021
	-0.035

Table 11: Shaft tolerances for use with H6 housings

D_i	C_D
10 mm	0.005 - 0.078
50 mm	0.005 - 0.130

Table 12: Clearance vs bearing diameter

Sizing

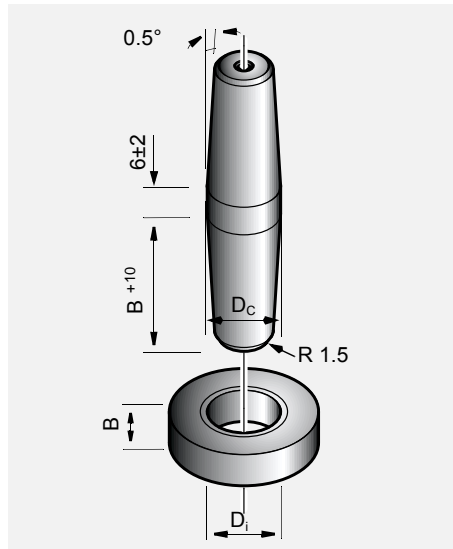

Fig. 24: Burnishing tool

The burnishing or fine boring of the bore of an assembled DU bush in order to achieve a smaller clearance tolerance is only permissible if a substantial reduction in performance is acceptable. Fig. 24 shows a recommended burnishing tool for the sizing of DU bushes.

The coining section of the burnishing tool should be case hardened (case depth 0.6-1.2 mm, HRC 60±2) and polished ($R_z \approx 1\mu\text{m}$).

Note: Ball burnishing of DU bushes is not recommended.

Assembled bush Inside- \varnothing	Required bush Inside- \varnothing	Required burnishing tool diameter D_c
$D_{i,a}$	$D_{i,a} + 0.025$	$D_{i,a} + 0.06$
$D_{i,a}$	$D_{i,a} + 0.038$	$D_{i,a} + 0.08$
$D_{i,a}$	$D_{i,a} + 0.050$	$D_{i,a} + 0.1$

Table 13: Burnishing tool tolerances

The values given in Table 13 indicate the dimensions of the burnishing tool required to give specific increases in the bearing bore diameter.

Exact values must be determined by test.

The reduction in bearing performance as a result of burnishing is allowed for in the bearing life calculation by the application factor a_c (Table 8, Page 16).

6.3 Counterface Design

The suitability of mating surface materials and recommendations of mating surface finish for use with DU are discussed in detail on page 15.

DU is normally used in conjunction with ferrous journals and thrust faces, but in damp or corrosive surroundings, particularly without the protection of oil or grease, stainless steel, hard chromium plated mild steel, or hard anodised aluminium is recommended. When plated mating surfaces are specified the plating should possess adequate strength and adhesion, particularly if the bearing is to operate with high fluctuating loads.

The shaft or thrust collar used in conjunction with the DU bush or thrust washer must extend beyond the bearing surface in order to avoid cutting into it. The mating surface must also be free from grooves or flats, the end of the shaft should be given a lead-in chamfer and all sharp edges or projections which may damage the soft overlay of the DU must be removed.

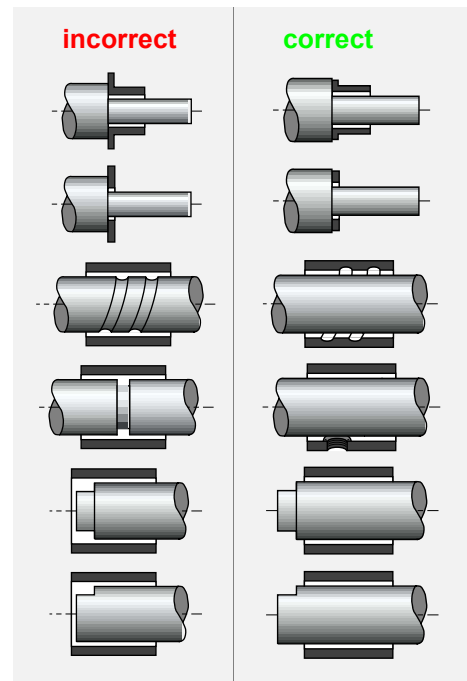

Fig. 25: Counterface Design

6.4 Installation

Fitting of cylindrical bushes

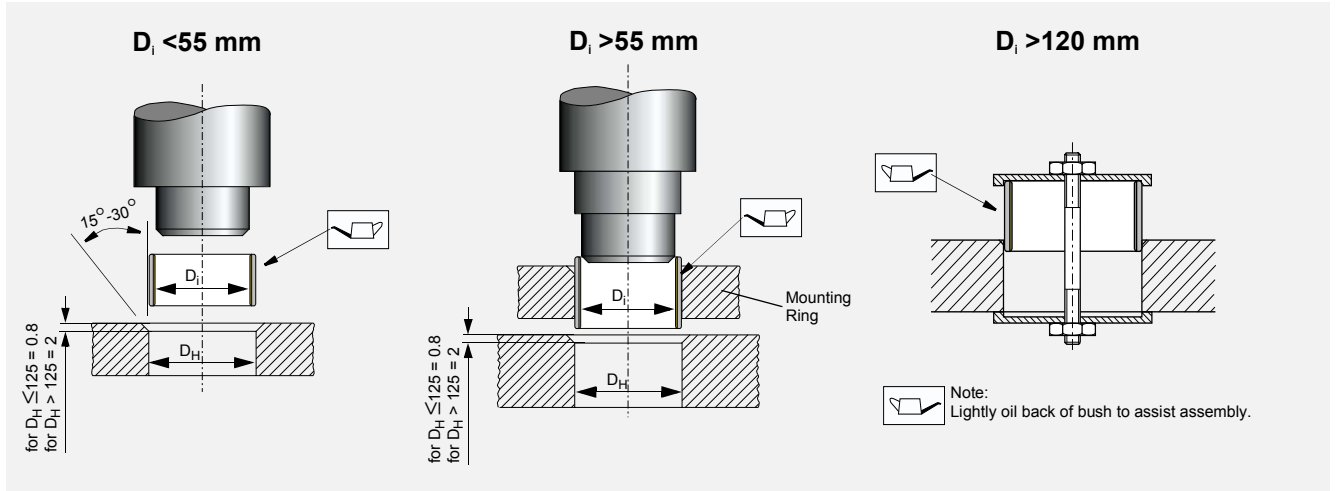

Fig. 26: Fitting of cylindrical bushes

Fitting of flanged bushes

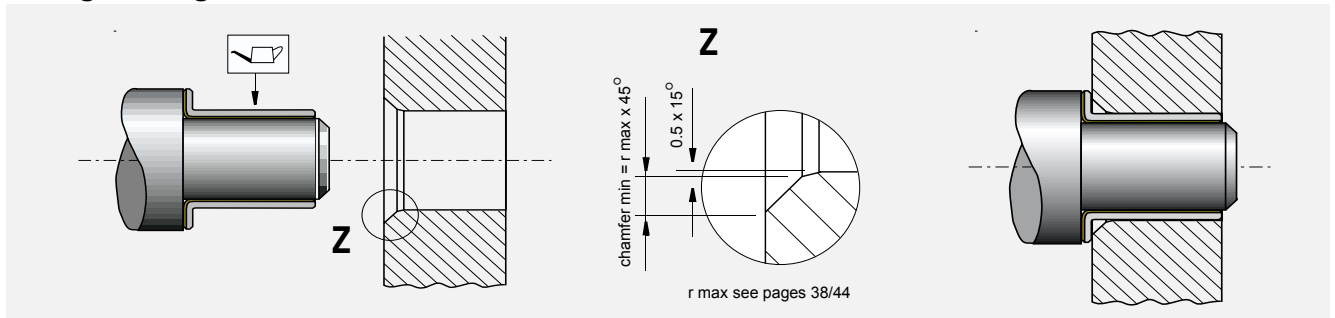

Fig. 27: Fitting of flanged bushes

Insertion Forces

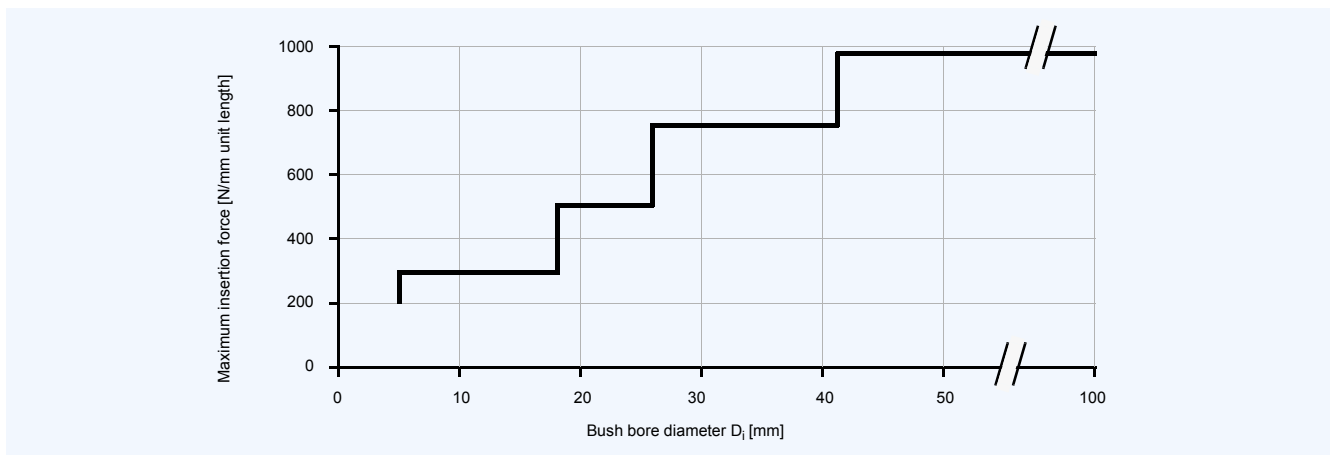

Fig. 28: Maximum Insertion Force

6 Bearing Assembly

Alignment

Accurate alignment is an important consideration for all bearing assemblies, but is particularly so for dry bearings because there is no lubricant to spread the load.

With DU bearings misalignment over the length of a bush (or pair of bushes), or over the diameter of a thrust washer should not exceed 0.020 mm as illustrated in Fig. 29.

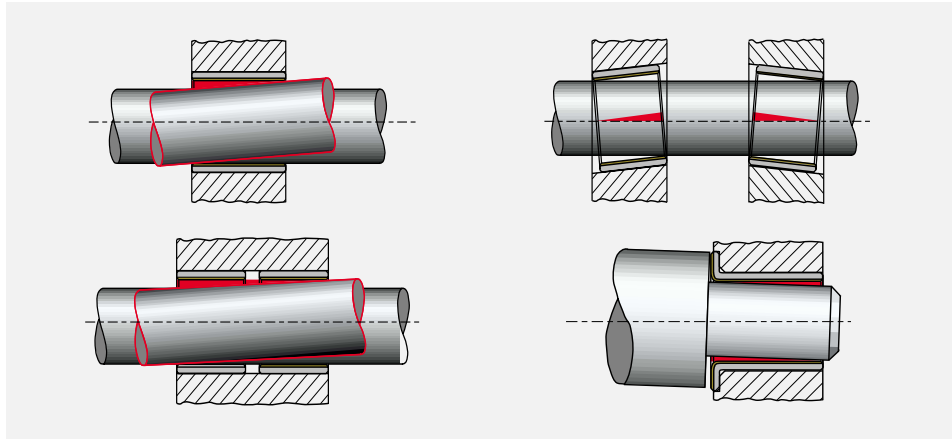

Fig. 29: Alignment

Sealing

While DU can tolerate the ingress of some contaminant materials into the bearing without loss of performance, where there is the possibility of highly abrasive material

entering the bearing, a suitable sealing arrangement, as illustrated in Fig. 30 should be provided.

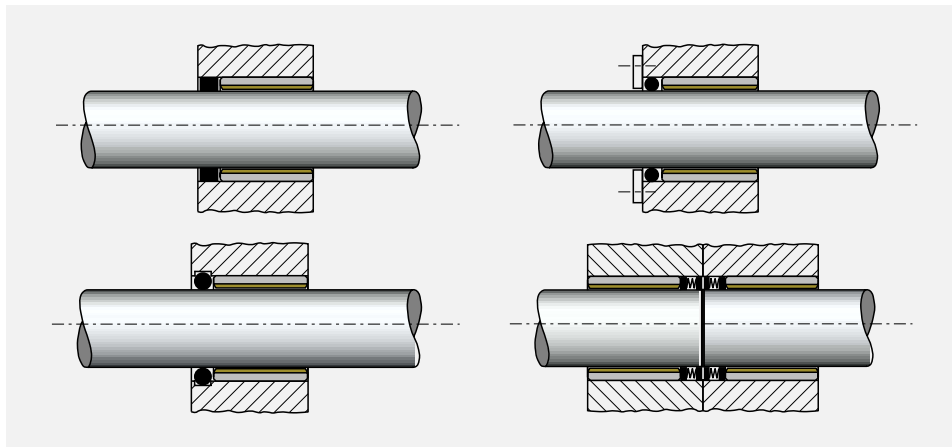

Fig. 30: Recommended sealing arrangements

6.5 Axial Location

Where axial location is necessary, it is advisable to fit DU thrust washers in con-

junction with DU bushes, even when the axial loads are low.

Fitting of Thrust Washers

DU thrust washers should be located in a recess as shown in Fig. 31. The recess diameter should be 0.125 mm larger than the washer diameter and the depth as given in the product tables.

If a recess is not possible one of the following methods may be used:

- Two dowel pins
- Two screws
- Adhesive
- Soldering

Important Note

- Ensure the washer ID does not touch the shaft after assembly
- Ensure that the washer is mounted with the steel backing to the housing
- Dowel pins should be recessed 0.25 mm below the bearing surface
- Screws should be countersunk 0.25 mm below the bearing surface
- DU must not be heated above 320 °C
- Contact adhesive manufacturers for guidance selection of suitable adhesives
- Protect the bearing surface to prevent contact with adhesive

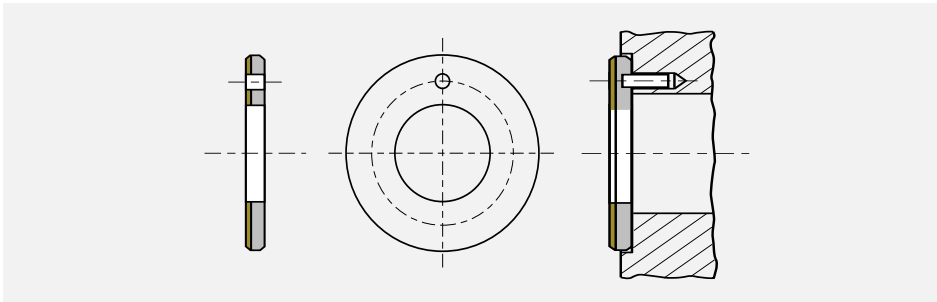

Fig. 31: Installation of Thrust-Washer

Grooves for Wear Debris Removal

Tests with thrust washers have demonstrated that for optimum dry wear performance at specific loads in excess of 35 N/mm², four wear debris removal grooves should

be machined in the bearing surface as shown in Fig. 32.

Grooves in bushes have not been found to be beneficial in this respect.

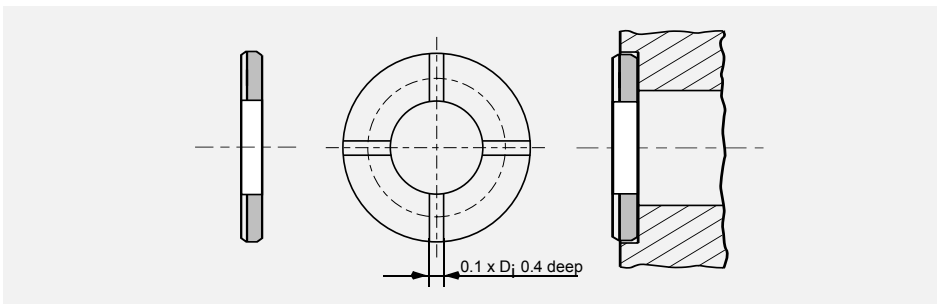

Fig. 32: Debris removal Grooves

Slideways

DU strip material for use as slideway bearings should be installed using one of the following methods:

- Countersunk screws
- Adhesives
- Mechanical location as shown in Fig. 33

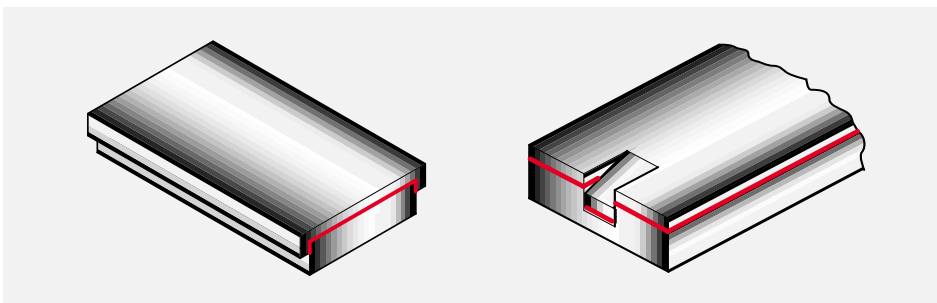

Fig. 33: Mechanical location of DU slideplates

7 Modification

7.1 Cutting and Machining

The modification of DU bearing components requires no special procedures. In general it is more satisfactory to perform machining or drilling operations from the PTFE side in order to avoid burrs. When cutting is done from the steel side, the

minimum cutting pressure should be used and care taken to ensure that any steel or bronze particles protruding into the remaining bearing material, and all burrs, are removed.

Drilling Oil Holes

Bushes should be adequately supported during the drilling operation to ensure that

no distortion is caused by the drilling pressure.

Cutting Strip Material

DU strip material may be cut to size by any one of the following methods.

Care must be taken to protect the bearing surface from damage and to ensure that no deformation of the strip occurs:

- Using side and face cutter, or slitting saw, with the strip held flat and securely

on a horizontal milling machine.

- Cropping
- Guillotine (For widths less than 90 mm only)
- Water-jet cutting
- Laser cutting (see Health Warning)

7.2 Electroplating

DU Components

In order to provide some protection in mildly corrosive environments the steel back and end faces of standard range DU bearings are tin flashed.

If exposed to corrosive liquids further protection should be provided and in very corrosive conditions DU-B should be considered.

DU can be electroplated with most of the conventional electroplating metals including the following:

- zinc ISO 2081-2
- cadmium ISO 2081-2
- nickel ISO 1456-8
- hard chromium ISO 1456-8

For the harder materials if the specified plating thickness exceeds approximately 5 μm then the housing diameter should be increased by twice the plating thickness in order to maintain the correct assembled bearing bore size.

With light deposits of materials such as cadmium, no special precautions are necessary. Harder materials such as nickel however, may strike through the PTFE/lead surface layer of DU and it is advisable to use an appropriate method of masking the bearing surface.

Where electrolytic attack is possible tests should be conducted to ensure that all the materials in the bearing environment are mutually compatible.

Mating Surfaces

DU can be used against some plated materials as indicated on page 15.

Care should be taken to ensure that the recommended shaft sizes and surface finish are achieved after the plating process.

8 Standard Products

8.1 DU Cylindrical Bushes

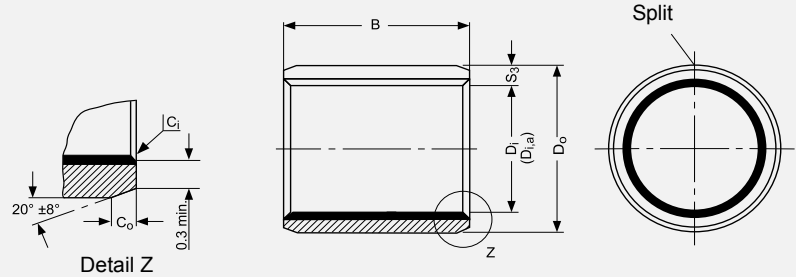

Dimensions and Tolerances according to ISO 3547 and GSP-Specifications

Part No.	Nominal Diameter		Bush Wall S ₃	Length B	Shaft-∅ D _J	Housing-∅ D _H	Ass. Inside-∅ D _{i,a}	Clearance C _D																																																																																								
	D _i	D _o							max. min.	max. min.	max. min.	max. min.	max. min.																																																																																			
0203DU	2	3.5	0.745 0.725	3.25	2.000 1.994	3.508 3.500	2.058 2.010	0.064 0.010																																																																																								
0205DU				2.75					5.25 4.75	0303DU	3	4.5	0.750 0.730	3.25	3.000 2.994	4.508 4.500	3.048 3.000	0.054 0.000	0305DU	2.75	5.25 4.75	0306DU	6.25 5.75	0403DU	4	5.5	0.750 0.730	3.25	4.000 3.992	5.508 5.500	4.048 4.000	0.056 0.000	0404DU	2.75	4.25	0406DU	3.75	6.25 5.75	0410DU	10.25 9.75	0505DU	5.25 4.75	0508DU	5	7	1.005 0.980	8.25	4.990 4.978	7.015 7.000	5.055 4.990	0.077 0.000	0510DU	7.75	10.25 9.75	0604DU	4.25 3.75	6.25 5.75	0606DU	6	8	1.005 0.980	5.75	5.990 5.978	8.015 8.000	6.055 5.990	0.083 0.003	0608DU	8.25	7.75	0610DU	10.25 9.75	0710DU	7	9	10.25 9.75	6.987 6.972	9.015 9.000	7.055 6.990	0806DU	8	10	1.005 0.980	6.25	7.987 7.972	10.015 10.000	8.055 7.990	0.083 0.003	0808DU	5.75	8.25	0810DU	7.75	10.25 9.75	0812DU	12.25 11.75	
0303DU	3	4.5	0.750 0.730	3.25	3.000 2.994	4.508 4.500	3.048 3.000	0.054 0.000																																																																																								
0305DU				2.75					5.25 4.75																																																																																							
0306DU				6.25 5.75																																																																																												
0403DU	4	5.5	0.750 0.730	3.25	4.000 3.992	5.508 5.500	4.048 4.000	0.056 0.000																																																																																								
0404DU				2.75					4.25																																																																																							
0406DU				3.75					6.25 5.75																																																																																							
0410DU				10.25 9.75																																																																																												
0505DU				5.25 4.75																																																																																												
0508DU	5	7	1.005 0.980	8.25	4.990 4.978	7.015 7.000	5.055 4.990	0.077 0.000																																																																																								
0510DU				7.75					10.25 9.75																																																																																							
0604DU				4.25 3.75					6.25 5.75																																																																																							
0606DU	6	8	1.005 0.980	5.75	5.990 5.978	8.015 8.000	6.055 5.990	0.083 0.003																																																																																								
0608DU				8.25					7.75																																																																																							
0610DU				10.25 9.75																																																																																												
0710DU				7					9	10.25 9.75	6.987 6.972	9.015 9.000	7.055 6.990																																																																																			
0806DU	8	10	1.005 0.980	6.25	7.987 7.972	10.015 10.000	8.055 7.990	0.083 0.003																																																																																								
0808DU				5.75					8.25																																																																																							
0810DU				7.75					10.25 9.75																																																																																							
0812DU				12.25 11.75																																																																																												
														All dimensions in mm																																																																																		

ID and OD chamfers

S ₃	C _o	C _i	S ₃	C _o	C _i
0.75	0.5 ± 0.3	-0.1 to -0.4	2	1.2 ± 0.4	-0.1 to -0.7
1	0.6 ± 0.4	-0.1 to -0.5	2.5	1.6 ± 0.8	-0.2 to -1.0
1.5	0.6 ± 0.4	-0.1 to -0.7			

8 Standard Products

Part No.	Nominal Diameter		Bush Wall S ₃	Length B	Shaft-∅ D _J	Housing-∅ D _H	Ass. Inside-∅ D _{i,a}	Clearance C _D
	D _i	D _o						
1008DU	10	12	1.005 0.980	8.25	9.987 9.972	12.018 12.000	10.058 9.990	0.086 0.003
1010DU				7.75				
1012DU				10.25				
1015DU				9.75				
1020DU				12.25 11.75				
1208DU	12	14		8.25	11.984 11.966	14.018 14.000	12.058 11.990	
1210DU				7.75				
1212DU				10.25				
1215DU				9.75				
1220DU				12.25 11.75				
1225DU	15.25 14.75							
1310DU	13	15		10.25	12.984 12.966	15.018 15.000	13.058 12.990	
1320DU				9.75				
1405DU	14	16		5.25	13.984 13.966	16.018 16.000	14.058 13.990	
1410DU				4.75				
1412DU				10.25				
1415DU				9.75				
1420DU				12.25 11.75				
1425DU	15.25 14.75							
1510DU	15	17		10.25	14.984 14.966	17.018 17.000	15.058 14.990	
1512DU			9.75					
1515DU			12.25					
1520DU			11.75					
1525DU			15.25 14.75					
1610DU	16	18	10.25	15.984 15.966	18.018 18.000	16.058 15.990		
1612DU			9.75					
1615DU			12.25					
1620DU			11.75					
1625DU			15.25 14.75					
1720DU	17	19	20.25	16.984 16.966	19.021 19.000	17.061 16.990	0.095 0.006	
1810DU	18	20	10.25	17.984 17.966	20.021 20.000	18.061 17.990		
1815DU			9.75					
1820DU			15.25					
1825DU			14.75					

Part No.	Nominal Diameter		Bush Wall S ₃	Length B	Shaft-∅ D _J	Housing-∅ D _H	Ass. Inside-∅ D _{i,a}	Clearance C _D
	D _i	D _o						
2010DU	20	23	1.505 1.475	10.25	19.980 19.959	23.021 23.000	20.071 19.990	0.112 0.010
2015DU				9.75				
2020DU				15.25				
2025DU				14.75				
2030DU				20.25				
2215DU	22	25		15.25	21.980 21.959	25.021 25.000	22.071 21.990	
2220DU				14.75				
2225DU				20.25				
2230DU				19.75				
2415DU				25.25				
2420DU	24	27		30.25	23.980 23.959	27.021 27.000	24.071 23.990	
2425DU				29.75				
2430DU				15.25				
2515DU				14.75				
2520DU				20.25				
2525DU	25	28	19.75	24.980 24.959	28.021 28.000	25.071 24.990		
2530DU			25.25					
2550DU			24.75					
2815DU			30.25					
2820DU			29.75					
2825DU	28	32	50.25	27.980 27.959	32.025 32.000	28.085 27.990		
2830DU			49.75					
3010DU			15.25					
3015DU			14.75					
3020DU			20.25					
3025DU	30	34	19.75	29.980 29.959	34.025 34.000	30.085 29.990		
3030DU			25.25					
3040DU			24.75					
3220DU			30.25					
3230DU			29.75					
3240DU	32	36	40.25	31.975 31.950	36.025 36.000	32.085 31.990		
			39.75					
			40.25					

8 Standard Products

Part No.	Nominal Diameter		Bush Wall S ₃	Length B	Shaft-∅ D _J	Housing-∅ D _H	Ass. Inside-∅ D _{i,a}	Clearance C _D	
	D _i	D _o							max. min.
3520DU	35	39	2.005 1.970	20.25	34.975 34.950	39.025 39.000	35.085 34.990	0.135 0.015	
3530DU				19.75					
3535DU				30.25					
3540DU				29.75					
3550DU				35.25					
3720DU	34.75	37		41	20.25	36.975	41.025		37.085
4020DU	19.75	40		44	19.75	39.975 39.950	44.025 44.000		40.085 39.990
4030DU	30.25								
4040DU	29.75								
4050DU	40.25								
4050DU	39.75								
4520DU	50.25	45	50	49.75	44.975 44.950	50.025 50.000	45.105 44.990		
4530DU	19.75								
4540DU	30.25								
4545DU	29.75								
4550DU	40.25								
5020DU	39.75	50	55	39.75	49.975 49.950	55.030 55.000	50.110 49.990		
5030DU	50.25								
5040DU	49.75								
5050DU	60.25								
5060DU	59.75								
5520DU	20.25	55	60	19.75	54.970 54.940	60.030 60.000	55.110 54.990		
5525DU	25.25								
5530DU	24.75								
5540DU	30.25								
5550DU	29.75								
5555DU	40.25	60	65	39.75	59.970 59.940	65.030 65.000	60.110 59.990		
5560DU	50.25								
6020DU	49.75								
6030DU	60.25								
6040DU	59.75								
6050DU	70.25								
6060DU	69.75								
6070DU	69.75								

Part No.	Nominal Diameter		Bush Wall S ₃	Length B	Shaft-∅ D _J	Housing-∅ D _H	Ass. Inside-∅ D _{i,a}	Clearance C _D
	D _i	D _o						
6530DU	65	70	2.505 2.460	30.25 29.75	64.970 64.940	70.030 70.000	65.110 64.990	0.170 0.020
6550DU				50.25 49.75				
6570DU				70.25 69.75				
7040DU	70	75		40.25 39.75	69.970 69.940	75.030 75.000	70.110 69.990	
7050DU				50.25 49.75				
7070DU				70.25 69.75				
7560DU	75	80		60.25 59.75	74.970 74.940	80.030 80.000	75.110 74.990	
7580DU				80.25 79.75				
8060DU	80	85		60.50 59.50	80.000 79.954	85.035 85.000	80.155 80.020	
80100DU				100.50 99.50				
8530DU	85	90		30.50 29.50	85.000 84.946	90.035 90.000	85.155 85.020	
8560DU				60.50 59.50				
85100DU			100.50 99.50					
9060DU	90	95	60.50 59.50	90.000 89.946	95.035 95.000	90.155 90.020		
90100DU			100.50 99.50					
9560DU	95	100	60.50 59.50	95.000 94.946	100.035 100.000	95.155 95.020		
95100DU			100.50 99.50					
10050DU			50.50 49.50					
10060DU	100	105	60.50 59.50	100.000 99.946	105.035 105.000	100.155 100.020		
100115DU			115.50 114.50					
10560DU	105	110	60.50 59.50	105.000 104.946	110.035 110.000	105.155 105.020		
105115DU			115.50 114.50					
11060DU			110				115	60.50 59.50
110115DU	115.50 114.50							
11550DU	115	120	50.50 49.50	115.000 114.946	120.035 120.000	115.155 115.020		
11570DU			70.50 69.50					
12050DU	120	125	50.50 49.50	120.000 119.946	125.040 125.000	120.210 120.070		
12060DU			60.50 59.50					
120100DU			100.50 99.50					
125100DU	125	130	2.490 2.440	100.50 99.50	125.000 124.937	130.040 130.000	125.210 125.070	
13060DU	130	135	60.50 59.50	130.000 129.937	135.040 135.000	130.210 130.070		
130100DU			100.50 99.50					

8 Standard Products

Part No.	Nominal Diameter		Bush Wall S ₃	Length B	Shaft-∅ D _J	Housing-∅ D _H	Ass. Inside-∅ D _{i,a}	Clearance C _D			
	D _i	D _o							max. min.	max. min.	max. min.
13560DU	135	140	2.465 2.415	60.50	135.000	140.040	135.210	0.273 0.070			
13580DU				59.50					134.937	140.000	135.070
14060DU	140	145		60.50	140.000	145.040	140.210				
140100DU				59.50					139.937	145.000	140.070
15060DU	150	155		60.50	150.000	155.040	150.210				
15080DU				59.50					149.937	155.000	150.070
150100DU				80.50					150.000	155.040	150.210
16080DU	160	165		80.50	160.000	165.040	160.210				
160100DU				79.50					159.937	165.000	160.070
180100DU	180	185		180.000	185.046	185.000	180.216		0.279 0.070		
200100DU	200	205		200.000	205.046	205.000	200.216		0.288 0.070		
210100DU	210	215		210.000	215.046	215.000	210.216				
220100DU	220	225		220.000	225.046	225.000	220.216				
250100DU	250	255		250.000	255.052	255.000	250.222		0.294 0.070		
300100DU	300	305		300.000	305.052	305.000	300.222		0.303 0.070		

8.2 DU Flanged Bushes

Dimensions and Tolerances according to ISO 3547 and GSP-Specifications

S ₃	1,0	1,5	2,0	2,5
r	1 ^{-0,5}	1 ±0,5	1,4 ±0,5	2 ±0,5

Part No.	Nominal Diameter		Bush Wall S ₃	Flange Wall S _{fl}	Flange-∅ D _{fl}	Length B	Shaft-∅ D _J	Housing-∅ D _H	Ass. Inside-∅ D _{i,a}	Clearance C _D
	D _i	D _o								
BB0304DU	3	4.5	0.750 0.730	0.800 0.700	7.500	4.25	3.000	4.508	3.048	0.054
BB0404DU	4	5.5			6.500		2.994	4.500	3.000	0.000
BB0505DU	5	7	1.005 0.980	1.050 0.950	9.500	4.25	4.000	5.508	4.048	0.056 0.000
BB0604DU	6	8			8.500		3.992	4.500	4.000	
BB0608DU					10.500	5.25	4.990	7.015	5.055	0.077 0.000
	9.500	4.75	4.978	7.000	4.990					
	12.5	3.75	5.990	8.015	6.055					
	11.5	8.25	5.978	8.000	5.990					
		7.75								

Part No.	Nominal Diameter		Bush Wall S ₃	Flange Wall S _f	Flange-∅ D _f	Length B	Shaft-∅ D _J	Housing-∅ D _H	Ass. Inside-∅ D _{i,a}	Clearance C _D										
	D _i	D _o									max. min.	max. min.	max. min.	max. min.	max. min.	max. min.				
BB0806DU	8	10	1.005 0.980	1.050 0.950	15.5 14.5	5.75	7.987 7.972	10.015 10.000	8.055 7.990	0.083 0.003										
BB0808DU						5.25														
BB0810DU						7.75 7.25														
BB1007DU	10	12			1.005 0.980	1.050 0.950	18.5 17.5	7.25 6.75	9.987 9.972	12.018 12.000	10.058 9.990	0.086 0.003								
BB1009DU								9.25												
BB1012DU								8.75 12.25 11.75												
BB1017DU								17.25 16.75												
BB1207DU								7.25 6.75												
BB1209DU	12	14					1.005 0.980	1.050 0.950	20.5 19.5	9.25 8.75	11.984 11.966	14.018 14.000	12.058 11.990	0.092 0.006						
BB1212DU										12.25 11.75										
BB1217DU										17.25 16.75										
BB1412DU										12.25 11.75										
BB1417DU	14	16							1.005 0.980	1.050 0.950	22.5 21.5	17.25 16.75	13.984 13.966	16.018 16.000	14.058 13.990	0.092 0.006				
BB1509DU												9.25 8.75								
BB1512DU	15	17									1.005 0.980	1.050 0.950	23.5 22.5	12.25 11.75	14.984 14.966	17.018 17.000	15.058 14.990	0.095 0.006		
BB1517DU			17.25 16.75																	
BB1612DU			12.25 11.75																	
BB1617DU	16	18	1.005 0.980	1.050 0.950									24.5 23.5	17.25 16.75	15.984 15.966	18.018 18.000	16.058 15.990	0.112 0.010		
BB1812DU					12.25 11.75															
BB1817DU	18	20			1.005 0.980	1.050 0.950							26.5 25.5	17.25 16.75	17.984 17.966	20.021 20.000	18.061 17.990	0.126 0.010		
BB1822DU														22.25 21.75						
BB2012DU														11.75 11.25						
BB2017DU	20	23											1.505 1.475	1.600 1.400	30.5 29.5	16.75 16.25	19.980 19.959	23.021 23.000	20.071 19.990	0.135 0.015
BB2022DU							21.75 21.25													
BB2512DU							11.75 11.25													
BB2517DU	25	28					1.505 1.475	1.600 1.400							35.5 34.5	16.75 16.25	24.980 24.959	28.021 28.000	25.071 24.990	0.155 0.015
BB2522DU																21.75 21.25				
BB3016DU									16.25 15.75											
BB3026DU	30	34							2.005 1.970	2.100 1.900					42.5 41.5	26.25 25.75	29.980 29.959	34.025 34.000	30.085 29.990	0.165 0.015
BB3516DU											16.25 15.75									
BB3526DU											26.25 25.75									
BB4016DU	40	44									2.005 1.970	2.100 1.900			53.5 52.5	16.25 15.75	39.975 39.950	44.025 44.000	40.085 39.990	0.175 0.015
BB4026DU			26.25 25.75																	
BB4516DU			16.25 15.75																	
BB4526DU	45	50	2.505 2.460	2.600 2.400	58.5 57.5	26.25 25.75									44.975 44.950	50.025 50.000	45.105 44.990	0.185 0.015		

All dimensions in mm

8 Standard Products

8.3 DU Flanged Washers

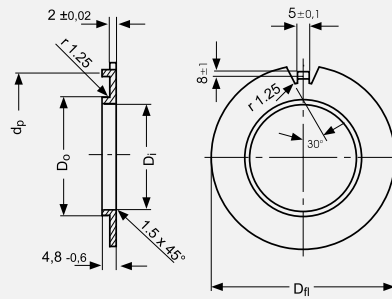
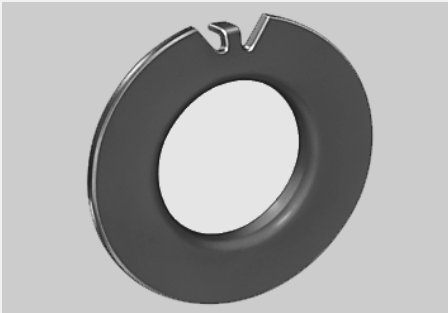

Part No.	Inside-∅ D _i	Body-∅ D _o	Outside-∅ D _f	Location-∅ d _p
	max. min.	max. min.	max. min.	max. min.
BS 40 DU	40.7	44.000	75.0	65.0
	40.2	43.900	74.5	64.5
BS 50 DU	51.5	55.000	85.0	75.0
	51.0	54.880	84.5	74.5
BS 60 DU	61.5	65.000	95.0	85.0
	61.0	64.880	94.5	84.5
BS 70 DU	71.5	75.000	110.0	100.0
	71.0	74.880	109.5	99.5
BS 80 DU	81.5	85.000	120.0	110.0
	81.0	84.860	119.5	109.5
BS 90 DU	91.5	95.000	130.0	120.0
	91.0	94.860	129.5	119.5
BS 100 DU	101.5	105.000	140.0	130.0
	101.0	104.860	139.5	129.5

8.4 DU Thrust Washer

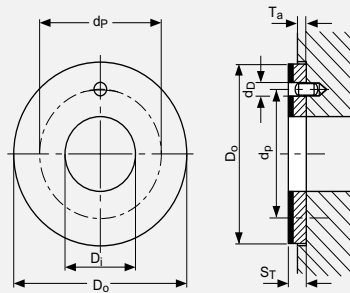
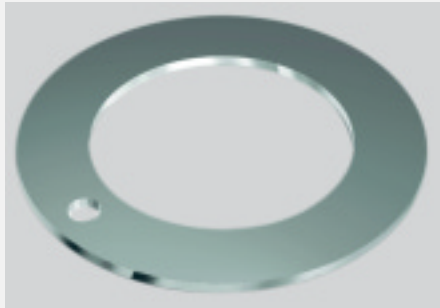

Part No.	Inside- \varnothing D_i		Outside- \varnothing D_o	Wall thickness S_T		Dowel hole- \varnothing d_D		Dowel hole PCD- $\varnothing d_P$		Recess Depth T_a	
	min.	max.		max.	min.	max.	min.	max.	min.	max.	
WC 08 DU	10.00	10.25	20.00 19.75	1.50 1.45	No Hole	No Hole	1.20 0.95				
WC 10 DU	12.00	12.25	24.00 23.75		1.875 1.625	18.12 17.88					
WC 12 DU	14.00	14.25	26.00 25.75		2.375 2.125	20.12 19.88					
WC 14 DU	16.00	16.25	30.00 29.75			22.12 21.88					
WC 16 DU	18.00	18.25	32.00 31.75		3.375 3.125	25.12 24.88					
WC 18 DU	20.00	20.25	36.00 35.75			28.12 27.88					
WC 20 DU	22.00	22.25	38.00 37.75		4.375 4.125	30.12 29.88					
WC 22 DU	24.00	24.25	42.00 41.75			33.12 32.88					
WC 24 DU	26.00	26.25	44.00 43.75		61.12 60.88	35.12 34.88					
WC 25 DU	28.00	28.25	48.00 47.75			38.12 37.88					
WC 30 DU	32.00	32.25	54.00 53.75		65.12 64.88	43.12 42.88					
WC 35 DU	38.00	38.25	62.00 61.75			50.12 49.88					
WC 40 DU	42.00	42.25	66.00 65.75		76.12 75.88	54.12 53.88					
WC 45 DU	48.00	48.25	74.00 73.75			61.12 60.88					
WC 50 DU	52.00	52.25	78.00 77.75	1.70 1.45	65.12 64.88						
WC 60 DU	62.00	62.25	90.00 89.75		76.12 75.88						

All dimensions in mm

8 Standard Products

8.5 DU-B Cylindrical Bushes

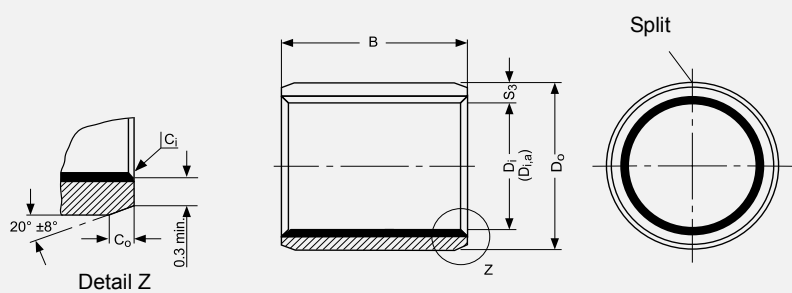
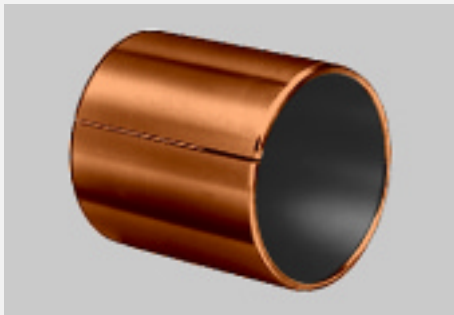

Dimensions and Tolerances according to ISO 3547 and GSP-Specifications

Part No.	Nominal Diameter		Wall thickness S ₃	Length B	Shaft-∅ D _J		Housing-∅ D _H		Assembled Inside-∅ D _{i,a}		Clearance C _D
	D _i	D _o			max.	min.	max.	min.	max.	min.	
0203 DU-B	2	3.5	0.750 0.730	3.25	2.000	3.508	2.048	2.000	0.054	0.000	
0205 DU-B				2.75							
0306 DU-B	3	4.5	0.750 0.730	5.25	3.000	4.508	3.048	3.000	0.056	0.000	
0406 DU-B				4.75							
0505 DU-B	4	5.5	0.750 0.730	6.25	4.000	5.508	4.048	4.000	0.056	0.000	
0510 DU-B				5.75							
0606 DU-B	5	7	1.005 0.980	5.25	4.990	7.015	5.055	4.990	0.077	0.000	
0608 DU-B				4.75							
0610 DU-B	6	8	1.005 0.980	10.25	5.990	8.015	6.055	5.990	0.077	0.000	
0808 DU-B				9.75							
0812 DU-B	8	10	1.005 0.980	6.25	7.987	10.015	8.055	7.990	0.083	0.003	
1010 DU-B				5.75							
1015 DU-B	10	12	1.005 0.980	8.25	9.987	12.018	10.058	9.990	0.086	0.003	
1208 DU-B				7.75							
1210 DU-B	12	14	1.005 0.980	12.25	11.984	14.018	12.058	11.990	0.092	0.006	
1212 DU-B				11.75							
1215 DU-B	14	16	1.005 0.980	10.25	13.984	16.018	14.058	13.990	0.092	0.006	
1415 DU-B				14.75							
1420 DU-B	15	17	1.005 0.980	15.25	14.984	17.018	15.058	14.990	0.092	0.006	
1515 DU-B				19.75							
1525 DU-B	16	18	1.005 0.980	14.75	15.984	18.018	16.058	15.990	0.092	0.006	
1615 DU-B				24.75							
1625 DU-B	18	20	1.005 0.980	15.25	17.984	20.021	18.061	17.990	0.095	0.006	
1820 DU-B				19.75							
1825 DU-B	18	20	1.005 0.980	25.25	17.966	20.000	17.990	0.095	0.006		
1825 DU-B				24.75							

All dimensions in mm

Part No.	Nominal Diameter		Wall thickness S ₃	Length B	Shaft-∅ D _J	Housing-∅ D _H	Assembled Inside-∅ D _{i,a}	Clearance C _D
	D _i	D _o						
2015 DU-B	20	23	1.505 1.475	15.25 14.75	19.980 19.959	23.021 23.000	20.071 19.990	0.112 0.010
2020 DU-B				20.25 19.75				
2030 DU-B				30.25 29.75				
2215 DU-B	22	25		15.25 14.75	21.980 21.959	25.021 25.000	22.071 21.990	
2220 DU-B				20.25 19.75				
2225 DU-B				25.25 24.75				
2525 DU-B	25	28		24.980 24.959	28.021 28.000	25.071 24.990		
2830 DU-B	28	32		30.25 29.75	27.980 27.959	32.025 32.000	28.085 27.990	
3020 DU-B	30	34		20.25 19.75	29.980 29.959	34.025 34.000	30.085 29.990	
3030 DU-B				30.25 29.75				
3040 DU-B				40.25 39.75				
3520 DU-B	35	39		20.25 19.75	34.975 34.950	39.025 39.000	35.085 34.990	
3530 DU-B			30.25 29.75					
4030 DU-B			50.25 49.75					
4050 DU-B	40	44	39.975 39.950	44.025 44.000	40.085 39.990			
4530 DU-B	45	50	30.25 29.75	44.975 44.950	50.025 50.000	45.105 44.990		
4550 DU-B			50.25 49.75					
5040 DU-B			40.25 39.75					
5060 DU-B	50	55	60.25 59.75	49.975 49.950	55.030 55.000	50.110 49.990		
5540 DU-B	55	60	40.25 39.75	54.970 54.940	60.030 60.000	55.110 54.990		
6040 DU-B			59.970 59.940					
6070 DU-B			70.25 69.75					
7050 DU-B	70	75	50.25 49.75	69.970 69.940	75.030 75.000	70.110 69.990		
7070 DU-B			70.25 69.75					
8060 DU-B			60.50 59.50					
80100 DU-B	80	85	100.50 99.50	80.000 79.954	85.035 85.000	80.155 80.020		
9060 DU-B	90	95	60.50 59.50	90.000 89.946	95.035 95.000	90.155 90.020		
90100 DU-B			100.50 99.50					
10060 DU-B			60.50 59.50					
100115 DU-B	100	105	115.50 114.50	100.000 99.946	105.035 105.000	100.155 100.020		

ID and OD chamfers

S ₃	C _o	C _i	S ₃	C _o	C _i
0.75	0.5 ± 0.3	-0.1 to -0.4	2	1.2 ± 0.4	-0.1 to -0.7
1	0.6 ± 0.4	-0.1 to -0.5	2.5	1.6 ± 0.8	-0.2 to -1.0
1.5	0.6 ± 0.4	-0.1 to -0.7			

All dimensions in mm

8 Standard Products

8.6 DU-B Flanged Bushes

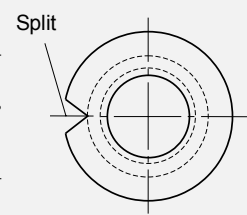
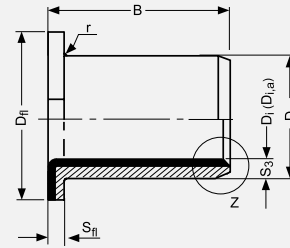
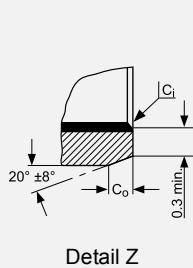
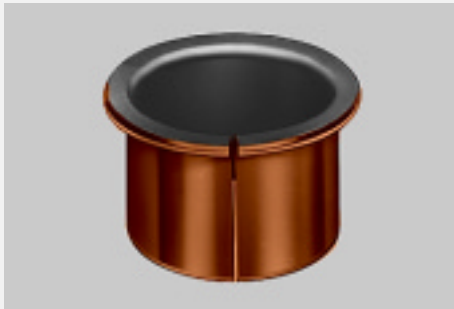

Dimensions and Tolerances according to ISO 3547 and GSP-Specifications

S ₃	1,0	1,5	2,0	2,5
r	1 ^{-0,5}	1 ± 0,5	1,4 ± 0,5	2 ± 0,5

Part No.	Nominal Diameter		Bush Wall S ₃	Flange Wall S _{fl}	Flange- ∅ D _{fl}	Length B	Shaft-∅ D _J	Housing- ∅ D _H	Ass. Inside- ∅ D _{i,a}	Clearance C _D
	D _i	D _o								
BB0304DU-B	3	4.5	0.750 0.730	0.800 0.700	7.500 6.500	4.25	3.000 2.994	4.508 4.500	3.048 3.000	0.054 0.000
BB0404DU-B	4	5.5			9.500 8.500	3.75	4.000 3.992	5.508 4.500	4.048 4.000	0.056 0.000
BB0505DU-B	5	7	1.005 0.980	1.050 0.950	10.500 9.500	5.25 4.75	4.990 4.978	7.015 7.000	5.055 4.990	0.077 0.000
BB0604DU-B	6	8			12.5 11.5	4.25 3.75	5.990 5.978	8.015 8.000	6.055 5.990	0.000
BB0806DU-B	8	10			15.5 14.5	5.75 5.25	7.987 7.972	10.015 10.000	8.055 7.990	0.083 0.000
BB0810DU-B						9.75 9.25	7.987 7.972			
BB1007DU-B	10	12			18.5 17.5	7.25 6.75	9.987 9.972	12.018 12.000	10.058 9.990	0.086 0.003
BB1012DU-B						12.25 11.75	9.987 9.972			
BB1207DU-B	12	14			20.5 19.5	7.25 6.75	11.984 11.966	14.018 14.000	12.058 11.990	0.092 0.006
BB1212DU-B						12.25 11.75	11.984 11.966			
BB1417DU-B	14	16			22.5 21.5	17.25 16.75	13.984 13.966	16.018 16.000	14.05 13.990	0.092 0.006
BB1512DU-B	15	17			23.5 22.5	12.25 11.75	14.984 14.966	17.018 17.000	15.058 14.990	0.092 0.006
BB1517DU-B			17.25 16.75	14.966						
BB1612DU-B	16	18	24.5 23.5	12.25 11.75	15.984 15.966	18.018 18.000	16.058 15.990	0.092 0.006		
BB1617DU-B				17.25 16.75	15.966					
BB1822DU-B	18	20	26.5 25.5	22.25 21.75	17.984 17.966	20.021 20.000	18.061 17.990	0.095 0.006		
BB2012DU-B	20	23	1.505 1.475	1.600 1.400	11.75 11.25	19.980 19.959	23.021 23.000	20.071 19.990	0.112 0.010	
BB2017DU-B					16.75 16.25	19.959				
BB2522DU-B	25	28	35.5 34.5	21.75 21.25	24.980 24.959	28.021 28.000	25.071 24.990	0.126 0.010		
BB3016DU-B	30	34	2.005 1.970	2.100 1.900	16.25 15.75	29.980 29.959	34.025 34.000	30.085 29.990	0.135 0.015	
BB3026DU-B					26.25 25.75	29.959 29.959				
BB3526DU-B	35	39	47.5 46.5	26.25 25.75	34.975 34.950	39.025 39.000	35.085 34.990	0.135 0.015		
BB4026DU-B	40	44	2.005 1.970	2.100 1.900	53.5 52.5	26.25 25.75	39.975 39.950	44.025 44.000	40.085 39.990	0.135 0.015
BB4526DU-B	45	50	2.505 2.460	2.600 2.400	58.5 57.5	26.25 25.75	44.975 44.950	50.025 50.000	45.105 44.990	0.155 0.015

8.7 DU Cylindrical Bushes - Inch sizes

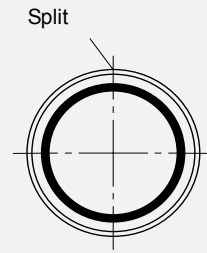
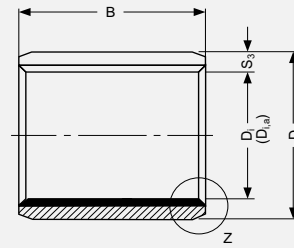
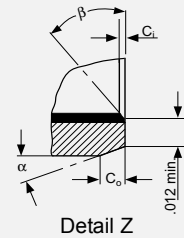
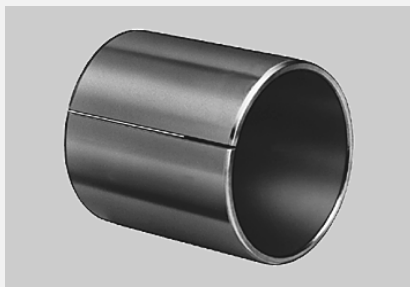

Part No.	Nominal Diameter			Bush Wall S ₃	Length B	Shaft-∅ D _J	Housing-∅ D _H	Ass. Inside-∅ D _{i,a}	Clearance C _D			
	D _i	D _o	B									
02DU02	1/8	3/16	1/8	0.0315 0.0305	0.1350 0.1150	0.1243 0.1236	0.1878 0.1873	0.1268 0.1243	0.0032 0.0000			
02DU03			3/16		0.1975 0.1775							
025DU025	5/32	7/32	5/32		0.16625 0.14265	0.1554 0.1547	0.2191 0.2186	0.1581 0.1556		0.0034 0.0002		
025DU04			1/4		0.2600 0.2400							
03DU03	3/16	1/4	3/16		0.1975 0.1775	0.1865 0.1858	0.2503 0.2497	0.1893 0.1867		0.0035 0.0002		
03DU04			1/4		0.2600 0.2400							
03DU06			3/8		0.3850 0.3650							
04DU04	1/4	5/16	1/4		0.2600 0.2400	0.2490 0.2481	0.3128 0.3122	0.2518 0.2492		0.0037 0.0002		
04DU06			3/8		0.3850 0.3650							
05DU06	5/16	3/8	3/8		0.0471 0.0461	0.5100 0.4900	0.3115 0.3106	0.3753 0.3747		0.3143 0.3117	0.0038 0.0002	
05DU08			1/2									0.3850 0.3650
06DU06	3/8	15/32	3/8			0.5100 0.4900	0.3740 0.3731	0.4691 0.4684		0.3769 0.3742		0.0038 0.0002
06DU08			1/2			0.7600 0.7400						
06DU12			3/4			0.5100 0.4900						
07DU08	7/16	17/32	1/2			0.5100 0.4900	0.4365 0.4355	0.5316 0.5309		0.4394 0.4367		0.0039 0.0002
07DU12			3/4			0.7600 0.7400						
08DU06	1/2	19/32	3/8	0.3850 0.3650		0.4990 0.4980	0.5941 0.5934	0.5019 0.4992	0.0039 0.0002			
08DU08			1/2	0.5100 0.4900								
08DU10			5/8	0.6350 0.6150								
08DU14			7/8	0.8850 0.8650								
09DU08			1/2	0.5100 0.4900						0.5615 0.5605		0.6566 0.6559
09DU12	3/4	0.7600 0.7400										

ID and OD chamfers

D _i	C _o	α	C _i	β
1/8" - 5/16"	0.008" - 0.024"	30°-45°	0.004" - 0.012"	30°-45°
3/8" - 11/16"	0.020" - 0.040"	20°-30°	0.005" - 0.025"	40°-55°
3/4" - 7"	0.020" - 0.040"	15°-25°	0.005" - 0.025"	40°-50°

8 Standard Products

Part No.	Nominal Diameter			Bush Wall S ₃	Length B	Shaft-∅ D _J	Housing-∅ D _H	Ass. Inside-∅ D _{La}	Clearance C _D
	D _i	D _o	B						
10DU08	5/8	23/32	1/2	0.0471 0.0461	0.5100 0.4900	0.6240 0.6230	0.7192 0.7184	0.6270 0.6242	0.0040 0.0002
10DU10			5/8		0.6350 0.6150				
10DU12			3/4		0.7600 0.7400				
10DU14			7/8		0.8850 0.8650				
11DU14	11/16	25/32	7/8	0.0627 0.0615	0.6865 0.6855	0.7817 0.7809	0.6895 0.6867	0.0046 0.0002	
12DU08	3/4	7/8	1/2		0.5100 0.4900	0.7491 0.7479	0.8755 0.8747		0.7525 0.7493
12DU12			3/4		0.7600 0.7400				
12DU16			1		1.0100 0.9900				
14DU12	7/8	1	3/4	0.0627 0.0615	0.7600 0.7400	0.8741 0.8729	1.0005 0.9997	0.8775 0.8743	0.0047 0.0001
14DU14			7/8		0.8850 0.8650				
14DU16			1		1.0100 0.9900				
16DU12			1		1 1/8				
16DU16	1	1.0100 0.9900							
16DU24	1 1/2	1.5100 1.4900							
18DU12	1 1/8	1 9/32	3/4	0.0784 0.0770	0.7600 0.7400	1.1238 1.1226	1.2818 1.2808	1.1278 1.1240	0.0052 0.0002
18DU16			1		1.0100 0.9900				
20DU12	1 1/4	1 13/32	3/4	0.0784 0.0770	0.7600 0.7400	1.2488 1.2472	1.4068 1.4058	1.2528 1.2490	0.0056 0.0002
20DU16			1		1.0100 0.9900				
20DU20			1 1/4		1.2600 1.2400				
20DU28			1 3/4		1.7600 1.7400				
22DU16			1		1.0100 0.9900				
22DU22	1 3/8	1 17/32	1 3/8	0.0784 0.0770	1.3850 1.3650	1.3738 1.3722	1.5318 1.5308	1.3778 1.3740	0.0056 0.0002
22DU28			1 3/4		1.7600 1.7400				
24DU16	1 1/2	1 21/32	1	0.0941 0.0923	1.0100 0.9900	1.4988 1.4972	1.6568 1.6558	1.5028 1.4990	0.0056 0.0002
24DU20			1 1/4		1.2600 1.2400				
24DU24			1 1/2		1.5100 1.4900				
24DU32			2		2.0100 1.9900				
26DU16			1 5/8		1 25/32				
26DU24	1 1/2	1.5100 1.4900							
28DU16	1 3/4	1 15/16	1	0.0941 0.0923	1.0100 0.9900	1.7487 1.7471	1.9381 1.9371	1.7535 1.7489	0.0064 0.0002
28DU24			1 1/2		1.5100 1.4900				
28DU28			1 3/4		1.7600 1.7400				
28DU32			2		2.0100 1.9900				

Part No.	Nominal Diameter			Bush Wall S ₃	Length B	Shaft-∅ D _J	Housing-∅ D _H	Ass. Inside-∅ D _{i,a}	Clearance C _D
	D _I	D _O	B						
30DU16	1 ⁷ / ₈	2 ¹ / ₁₆	1	0.0941 0.0923	1.0100 0.9900	1.8737 1.8721	2.0633 2.0621	1.8787 1.8739	0.0066 0.0002
30DU30			1 ⁷ / ₈		1.8850 1.8650				
30DU36			2 ¹ / ₄		2.2600 2.2400				
32DU16	2	2 ³ / ₁₆	1	0.0928 0.0902	1.0100 0.9900	1.9987 1.9969	2.1883 2.1871	2.0037 1.9989	0.0068 0.0002
32DU24			1 ¹ / ₂		1.5100 1.4900				
32DU32			2		2.0100 1.9900				
32DU40			2 ¹ / ₂		2.5100 2.4900				
36DU32	2 ¹ / ₄	2 ⁷ / ₁₆	2	0.0928 0.0902	2.0100 1.4900	2.2507 2.2489	2.4377 2.4365	2.2573 2.2509	0.0084 0.0002
36DU36			2 ¹ / ₄		2.2600 2.2400				
36DU40			2 ¹ / ₂		2.5100 2.4900				
36DU48			3		3.0100 2.9900				
40DU32	2 ¹ / ₂	2 ¹¹ / ₁₆	2	0.0928 0.0902	2.0100 1.9900	2.5011 2.4993	2.6881 2.6869	2.5077 2.5013	0.0084 0.0002
40DU40			2 ¹ / ₂		2.5100 2.4900				
40DU48			3		3.0100 2.9900				
40DU56			3 ¹ / ₂		3.5100 3.4900				
44DU32	2 ³ / ₄	2 ¹⁵ / ₁₆	2	0.0928 0.0902	2.0100 1.9900	2.7500 2.7482	2.9370 2.9358	2.7566 2.7502	0.0086 0.0002
44DU40			2 ¹ / ₂		2.5100 2.4900				
44DU48			3		3.0100 2.9900				
44DU56			3 ¹ / ₂		3.5100 3.4900				
48DU32	3	3 ³ / ₁₆	2 ¹ / ₂	0.0928 0.0902	2.5100 2.4900	3.0000 2.9982	3.1872 3.1858	3.0068 3.0002	0.0086 0.0002
48DU48			3		3.0100 2.9900				
48DU60			3 ³ / ₄		3.7600 3.7400				
56DU40	3 ¹ / ₂	3 ¹¹ / ₁₆	2 ¹ / ₂	0.0928 0.0902	2.5100 2.4900	3.5000 3.4978	3.6872 3.6858	3.5068 3.5002	0.0090 0.0002
56DU48			3		3.0100 2.9900				
56DU60			3 ³ / ₄		3.7600 3.7400				
64DU48	4	4 ³ / ₁₆	3	0.0928 0.0902	3.0100 2.9900	4.0000 3.9978	4.1872 4.1858	4.0068 4.0002	0.0090 0.0002
64DU60			3 ³ / ₄		3.7600 3.7400				
64DU76			4 ³ / ₄		4.7600 4.7400				
80DU48	5	5 ³ / ₁₆	3	0.0928 0.0902	3.0100 2.9900	4.9986 4.9961	5.1860 5.1844	5.0056 4.9988	0.0095 0.0002
80DU60			3 ³ / ₄		3.7600 3.7400				
96DU48	6	6 ³ / ₁₆	3	0.0928 0.0902	3.0100 2.9900	6.0000 5.9975	6.1874 6.1858	6.0070 6.0002	0.0097 0.0002
96DU60			3 ³ / ₄		3.7600 3.7400				
112DU60	7	7 ³ / ₁₆	3 ³ / ₄	0.0928 0.0902	3.7600 3.7400	6.9954 6.9929	7.1830 7.1812	7.0026 6.9956	0.0097 0.0002

8 Standard Products

8.8 DU Thrust Washers - Inch sizes

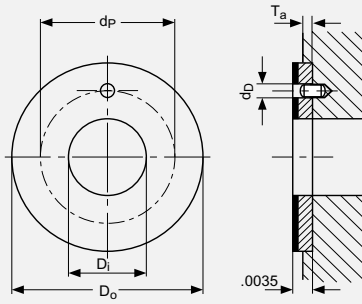
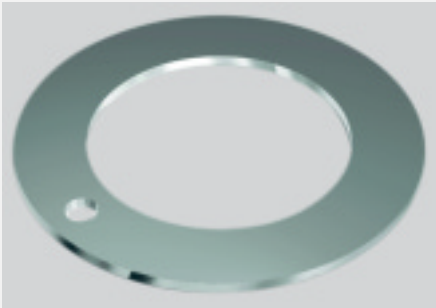

Part No.	Inside- \varnothing D_i		Outside- \varnothing D_o	Wall thickness S_T	Dowel hole- \varnothing d_D	Dowel hole PCD- \varnothing d_p	Recess Depth T_a	
	max.	min.						max. min.
DU06	0.510	0.500	0.875 0.865	0.063 0.061	0.077 0.067	0.692 0.682	0.050 0.040	
DU07	0.572	0.562	1.000 0.990		0.109 0.099	0.786 0.776		
DU08	0.635	0.625	1.125 1.115		0.171 0.161	0.880 0.870		
DU09	0.697	0.687	1.187 1.177		0.202 0.192	0.942 0.932		
DU10	0.760	0.750	1.250 1.240		2.005 1.995	1.005 0.995		
DU11	0.822	0.812	1.375 1.365		2.130 2.120	1.099 1.089		
DU12	0.885	0.875	1.500 1.490		2.255 2.245	1.192 1.182		
DU14	1.010	1.000	1.750 1.740		2.505 2.495	1.380 1.370		
DU16	1.135	1.125	2.000 1.990		2.630 2.620	1.567 1.557		
DU18	1.260	1.250	2.125 2.115		2.755 2.745	1.692 1.682		
DU20	1.385	1.375	2.250 2.240		0.093 0.091	1.817 1.807		0.080 0.070
DU22	1.510	1.500	2.500 2.490			2.505 2.495		
DU24	1.635	1.625	2.625 2.615	2.630 2.620				
DU26	1.760	1.750	2.750 2.740	2.755 2.745				
DU28	2.010	2.000	3.000 2.990					
DU30	2.135	2.125	3.125 3.115					
DU32	2.260	2.250	3.250 3.240					

8.9 DU Strip

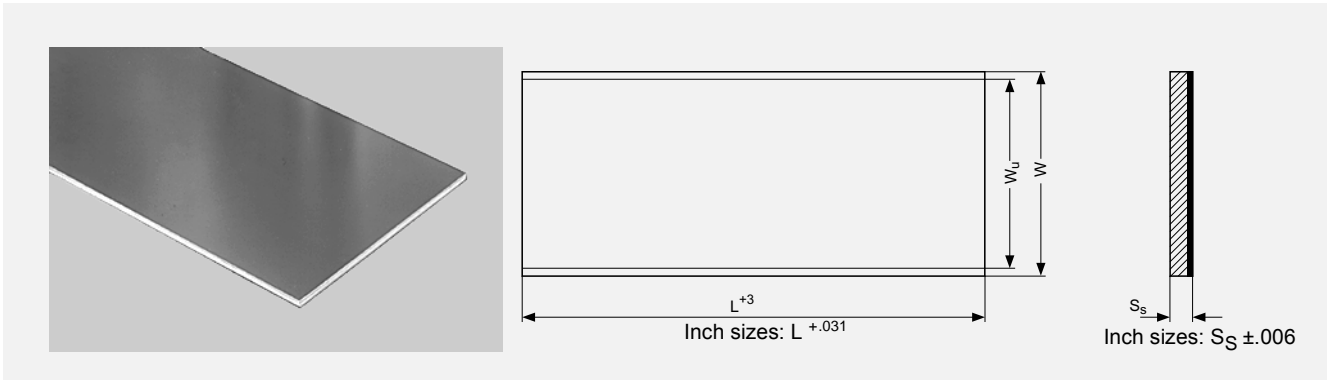

Part No.	Length L	Total Width W	Useable Width W_U	Thickness S_S	
				max.	min.
S 07150 DU	500	160	150	0.744	0.704
S 10200 DU		225	215	0.990	0.950
S 15240 DU		254	245	1.510	1.470
S 20240 DU				2.000	1.960
S 25240 DU				2.500	2.460
S 30240 DU				3.060	3.020
				All dimensions in mm	

8.10 DU-B Strip

Part No.	Length L	Total Width W	Useable Width W_U	Thickness S_S	
				max.	min.
S 10180 DU-B	500	193	180	0.990	0.950
S 15180 DU-B				1.500	1.470
S 20180 DU-B				2.000	1.960
S 25180 DU-B				2.500	2.460
				3.060	3.020
				All dimensions in mm	

8.11 DU Strip - Inch sizes

Part No.	Length L	Total Width W	Thickness S_S
Group 0	18	2.75	0.0277-0.0293
Group 1		4.00	0.0431-0.0447
Group 2			0.0586-0.0602
Group 3			0.0740-0.0756
Group 4			0.0897-0.0913
Group 5			0.1190-0.1210

9 Test Methods

9 Test Methods

9.1 Measurement of Wrapped Bushes

It is not possible to accurately measure the external and internal diameters of a wrapped bush in the free condition. In its free state a wrapped bush will not be perfectly cylindrical and the butt joint may be open. When correctly installed in a housing the butt joint will be tightly closed and the bush will conform to the housing.

For this reason the external diameter and internal diameter of a wrapped bush can only be checked with special gauges and test equipment.

The checking methods are defined in ISO 3547 Part 1 and 2 and ISO 12306 respectively.

Test A of ISO 3547 Part 2

Checking the external diameter in a test machine with checking blocks and adjusting mandrel.

Fig. 34: Test A, Data for drawing

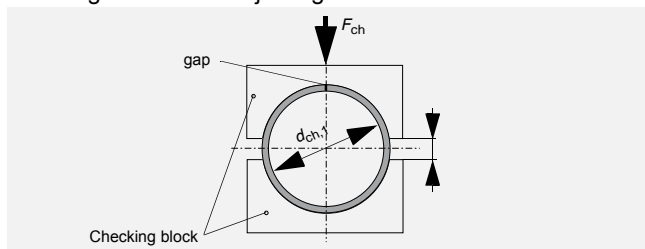

Test A of ISO 3547 Part 2 on 20DU15	
Test housing and mandrel $d_{ch,1}$	23.062 mm
Test load F_{ch}	4500 N
Limits for Δz	0 and -0.065 mm
Bush outside diameter D_o	23.035 to 23.075 mm

Table 14: Test A of ISO 3547 Part 2

Test B (alternatively to Test A)

Check external diameter with GO and NOGO ring gauges.

Test C

Checking the internal diameter of a bush pressed into a ring gauge, which nominal diameter corresponds to the dimension specified in table 5 of ISO 3547 Part 1.

Fig. 35: Example $D_i = 20$ mm

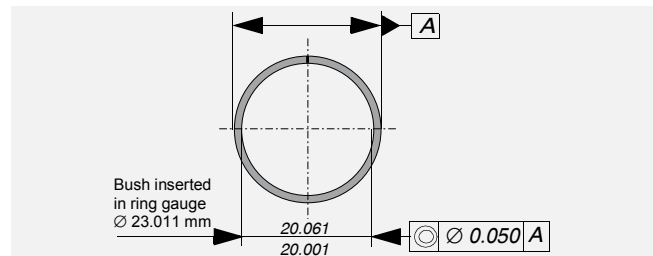

Fig. 35: Test C, Data for drawing

Measurement of Wall Thickness (alternatively to Test C)

The wall thickness is measured at one, two or three positions axially according to the bearing dimensions.

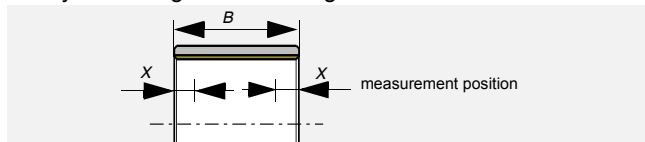

Fig. 36: Measurement position

B [mm]	X [mm]	measurement position
≤ 15	B/2	1
$> 15 \leq 50$	4	2
$> 50 \leq 90$	6 and B/2	3
> 90	8 and B/2	3

Table 15: Measurement position

Test D

Check external diameter by precision measuring tape.

Glacier Garlock Bearings warrants that products described in this brochure are free from defects in workmanship and material but unless expressly agreed in writing Glacier Garlock Bearings gives no warranty that these products are suitable for any particular purpose of for use under any specific conditions notwithstanding that such purpose would appear to be covered by this publication. Glacier Garlock Bearings accepts no liability for any loss, damage, or expense whatsoever arising directly or indirectly from use of its products. All business undertaken by Glacier Garlock Bearings is subject to its standard Conditions of Sale, copies of which are available upon request. Glacier Garlock Bearings products are subject to continual development and Glacier Garlock Bearings reserves the right to make changes in the specification and design of its products without prior notice.

GLACIER™ is a trademark of the EnPro Industries Inc., USA.

DU™ is a trademark of the EnPro Industries Inc., USA..

DU™-B is a trademark of the EnPro Industries Inc., USA.

Health Hazard - Warning

There are two separate aspects of health hazard which could arise from certain usage of DU materials.

Fabrication

At temperatures up to 250 °C the polytetrafluoroethylene (PTFE) present in the lining material is completely inert so that even on the rare occasions in which DU bushes are drilled, or sized, after assembly there is no danger in boring or burnishing.

At higher temperatures however, small quantities of toxic fumes can be produced and the direct inhalation of these can cause an influenza type of illness which may not appear for some hours but which subsides without after-effects in 24-48 hours.

Such fumes can arise from PTFE particles picked up on the end of a cigarette. Therefore smoking should be prohibited where DU is being machined.

Lead contamination of food, drink and other edible products

DU contains a small quantity of metallic lead (0.25 kg/m² of total bearing surface) and the designer should ensure that this does not contaminate any edible product being processed to the extent that it might cause a health hazard.

The majority of the lead is retained in the bearing, and that which escapes does so over a long period of time. The highest rate of release occurs during the bedding-in period which normally lasts for 1-2% of the life of the bearing. As a guide a MB2525DU bush with unidirectional load will emit 0.05g of lead in the bedding-in wear debris with a further 0.1g during the remaining 98% of the bearing life. 0.05g is sufficient, if evenly distributed, to contaminate 100 kg of food product to 0.5 ppm or 1000 litres of liquid to 0.05 ppm. If the rate of food processing is comparable to or less than these quantities per 1% of the bearing life, it should be sealed so as to prevent wear debris contaminating the product. These quantities are proportional to the surface area of the bearing and should be factored for other sizes, and increased by a factor of 3 if there is a rotating load. Where lead emission rates approach the critical level, and sealing is not effective, adequate prototype testing should be carried out to determine the bearing's operating life. Adverse conditions (extraneous material in the bearing, overloading etc) can decrease the life of the bearing and therefore increase the lead emission rates.