

Precision Modules PSK

RE 82 414/2003-08

The Drive & Control Company

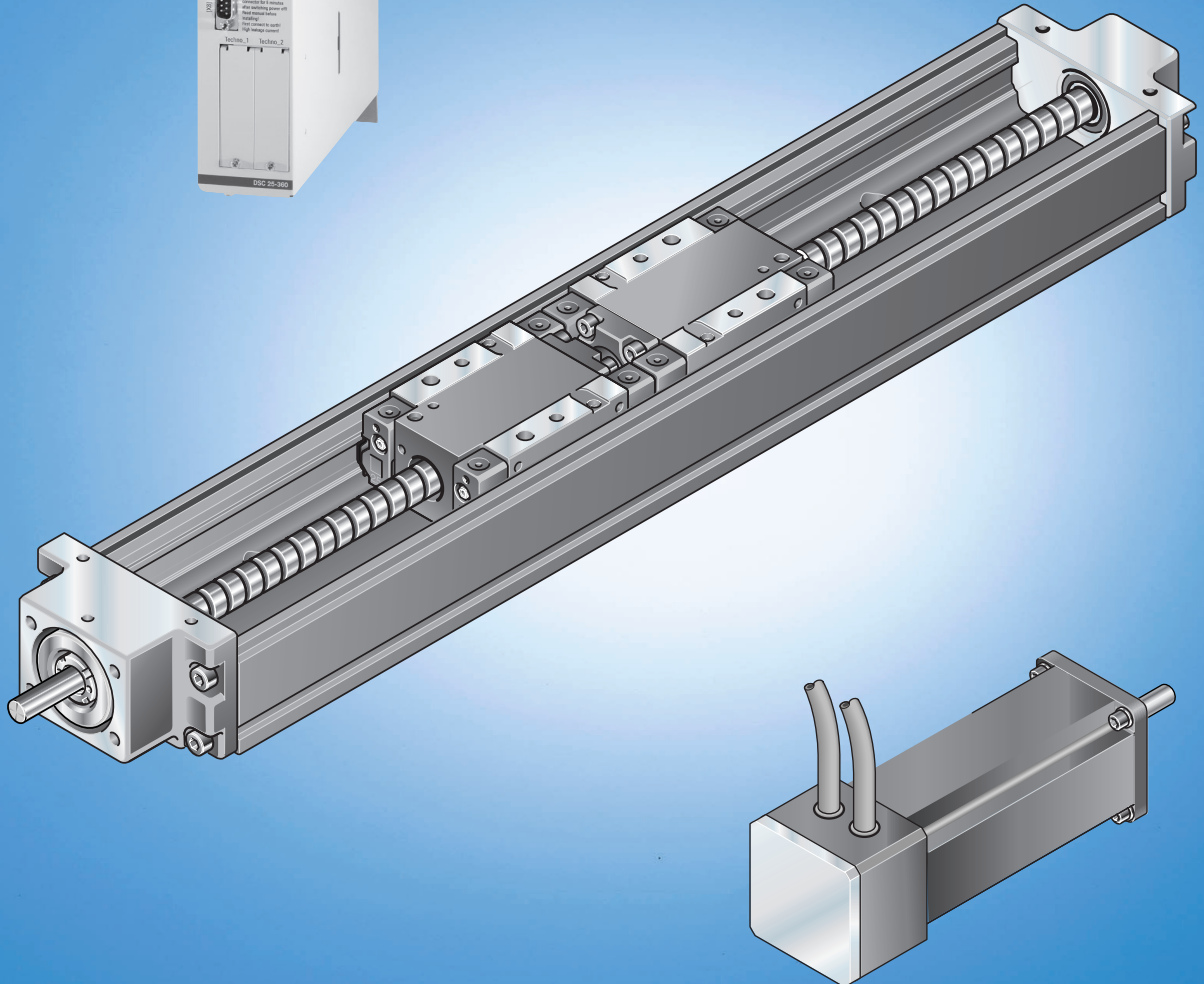

Rexroth – Linear Motion Technology

Ball Rail Systems

- Standard Ball Rail Systems
- Super Ball Rail Systems
- Ball Rail Systems with Aluminum Runner Blocks
- High-Speed Ball Rail Systems
- Corrosion-Resistant Ball Rail Systems
- Wide Ball Rail Systems
- Ball Rail Systems with Integrated Measuring System
- Clamping and Braking Units for Ball Rail Systems
- Rack and Pinion for Ball Rail Systems
- Miniature Ball Rail Systems
- ECO Ball Rail Systems
- Cam Roller Guides

Roller Rail Systems

- Standard Roller Rail Systems
- Wide Roller Rail Systems
- Heavy Duty Roller Rail Systems
- Roller Rail Systems with Integrated Measuring System
- Clamping and Braking Units for Roller Rail Systems
- Rack and Pinion for Roller Rail Systems

Linear Bushings and Shafts

- Linear Bushings, Linear Sets
- Shafts, Shaft Support Rails, Shaft Support Blocks
- Ball Transfer Units
- Traditional Engineering Components

Screw Drives

Linear Motion Systems

- Linear Motion Slides
 - Ball Screw Drive
 - Toothed Belt Drive
- Linear Modules
 - Ball Screw Drive
 - Toothed Belt Drive
 - Rack and Pinion Drive
 - Pneumatic Drive
 - Linear Motor
- Compact Modules
 - Ball Screw Drive
 - Toothed Belt Drive
 - Linear Motor

Precision Modules

- **Ball Screw Drive**

Ball Rail Tables

- Ball Screw Drive
- Linear Motor

Controllers, Motors, Electrical Accessories

Linear Actuators

Precision Modules PSK

A Solution to Many Problems	4
Product Overview	6
Types Available, Load Capacities	10
Precision Modules PSK (with Rail System and Ball Screw Assembly)	12
– Structure	12
– Technical Data	16
– Technical Data, Calculation	22
– Precision	24
– PSK 50	
Components and Ordering Data	26
Lengths and Hole Spacing	28
Dimension Drawings	29
– PSK 60	
Components and Ordering Data	34
Lengths and Hole Spacing	36
Dimension Drawings	37
– PSK 90	
Components and Ordering Data	42
Lengths and Hole Spacing	44
Dimension Drawings	45
Attachments and Mounting	50
– Switch Mounting Arrangements	50
– Motors	52
– Mounting	56
– Lubrication ports	57
Documentation	58
Inquiry/Order Form	59

Rexroth – Precision Modules PSK

A Solution to Many Problems

The tasks

- Driving
- Transporting
- Positioning

Total height, basic unit

Total length

Load capacities and moments

Static load

Speed

Precision

System complete with drive unit

Switch mounting arrangements

Cover options

Accessories

Documentation

26 mm to 46 mm

Up to 940 mm, or any intermediate length

Load capacity C up to 44670 N
Longitudinal moment M_L up to 1557 Nm
Torsional moment M_t up to 1478 Nm

Up to 800 kg

Up to 96 m/min

Repeatability up to 0.005 mm
Positioning accuracy up to 0.01 mm
Straightness accuracy up to 0.005 mm

AC servomotor or stepping motor with
mount, coupling or timing belt side drive;
complete with controller and control system

Switches over total travel range

Without cover
Cover plate
Sealing strip

Clamping fixtures, motor mounts

Moment of friction measurement, lead deviation
Running accuracy, positioning accuracy

The solution

**Rexroth –
Precision Modules**

Rexroth – Precision Modules PSK

Product Overview

Rexroth Precision Modules are ready-to-mount precision guide systems offering outstanding performance within a compact envelope. Excellent price/performance ratio. Available at short notice.

Structure

- Extremely compact and rigid precision steel profile (frame) with reference edge and integrated Rexroth rail system geometry
- Rexroth Precision Ball Screw Assemblies to tolerance grade 7 with zero-clearance nut systems
- Aluminum fixed bearing end block with preloaded bearing
- Floating bearing end block with double bearings
- Carriages in various designs:
Steel (St) or aluminum (Al), standard length or long, one or two carriages

▶ Rapid mounting and easy axis alignment thanks to machined reference edge on the frame

▶ One or two steel or aluminum carriages in standard length or long

Attachments

- Maintenance-free digital AC servo drives with integrated brake and attached feedback, or stepping motors
- Motor mount and coupling or side drive with timing belt
- Switches
- Aluminum profile cable duct

▶ Extremely stiff and precise miniature drive unit

Drive Controllers and Control Systems

- ▶ High positioning accuracy and repeatability due to Precision Ball Screw Assembly with zero-clearance nut system
- ▶ High travel speeds combined with high precision due to Ball Rail Systems, large screw diameters and leads, and double floating bearing
- ▶ Simple motor attachment due to locating feature and tapped mounting hole

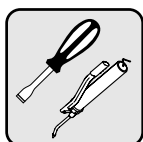

For mounting, maintenance and start-up, see "Instructions for PSK Precision Modules" RDEFI 82 475

PSK without cover

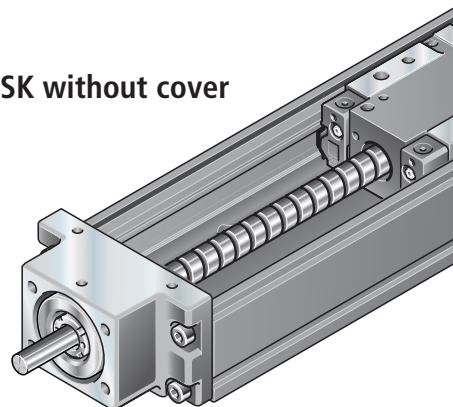

Fixed bearing end block with ball screw journal

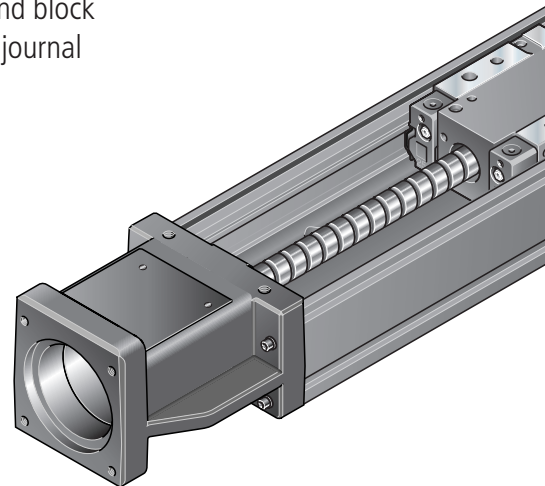

Fixed bearing end block with integrated motor mount

- ▶ Optimum running properties, high load capacities, high precision and high rigidity due to integrated Rexroth Ball Rail System

- ▶ Length:
 - Preferred lengths for even shorter delivery times
 - Customer specific (variable length, no standard length increments)

- ▶ Precise alignment and secure mounting of attachments thanks to tapped bores and pin holes in the carriage

- ▶ Adjustable switches over the entire travel range

- ▶ Low-cost maintenance provided by one-point lubrication (grease) for Ball Rail System and Precision Ball Screw Assembly

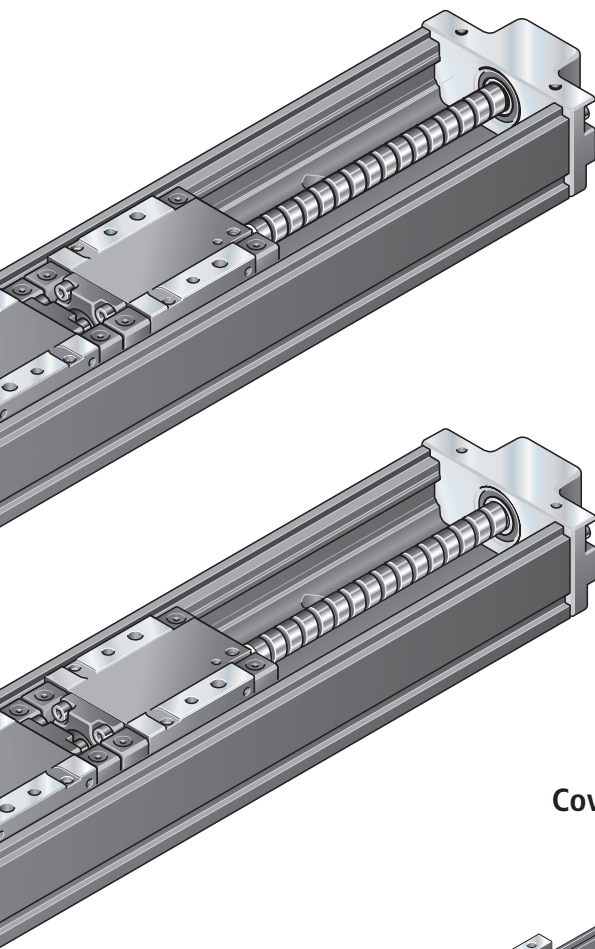

Internal elements protected by

Cover plate

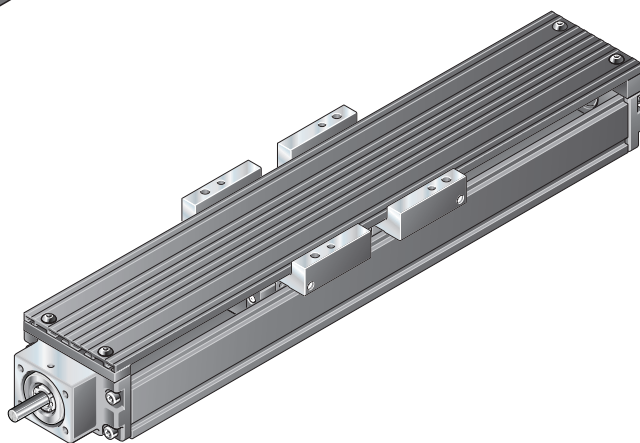

One or two steel or aluminum carriages in standard length or long

Sealing strip
(stainless steel strip)

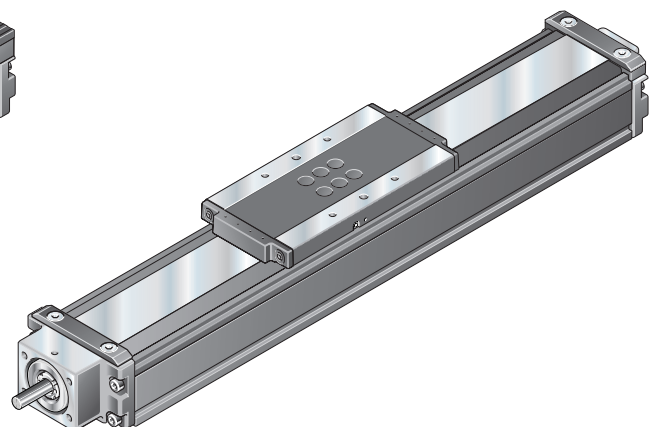

Aluminum carriage in standard length or long

Rexroth – Precision Modules PSK

Product Overview

Motor selection

in accordance with controllers and control systems

A choice can be made between several different motor/controller combinations to achieve the most cost-efficient solution for each customer application.

The motor/controller combination must always be taken into account when sizing the drive.

For more detailed information about motors and controllers, see the following catalogs:

- Servomotors: 82 710
- Stepping motors: 82 720

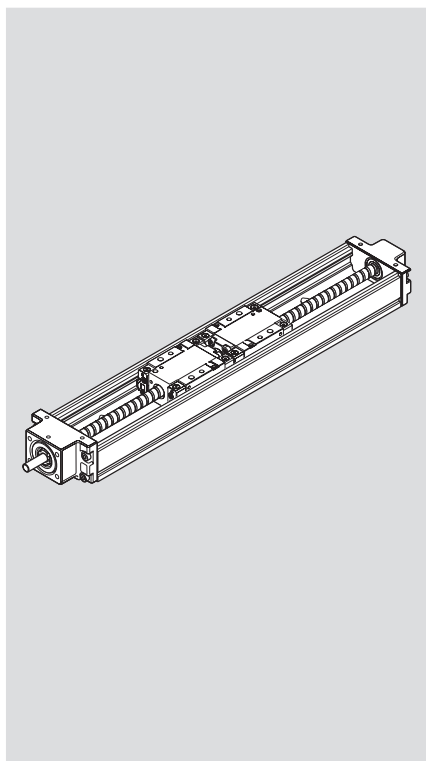

Servomotor MKD

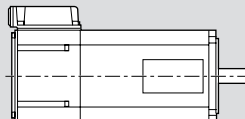

MKD 25B-144-KG1
MKD 41B-144 KG1

Digital controllers ECODRIVE

DKC



Servomotor MSI

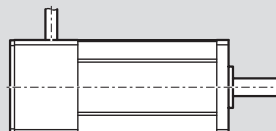

MSI 032
MSI 040
MSI 055

Digital controllers DSC

DSC

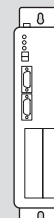

Servomotor MSM

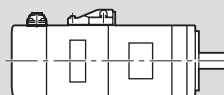

MSM 020B
MSM 030B
MSM 030C
MSM 040B

Digital controllers ECODRIVE Cs

DKC

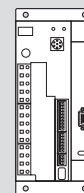

3-phase stepping motor

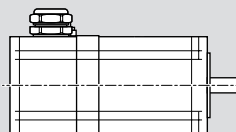

VRDM 368
VRDM 397
VRDM 3910

Power electronics

Twin
Line

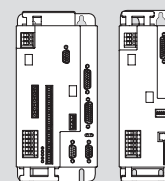

STAR step
control system

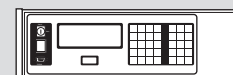

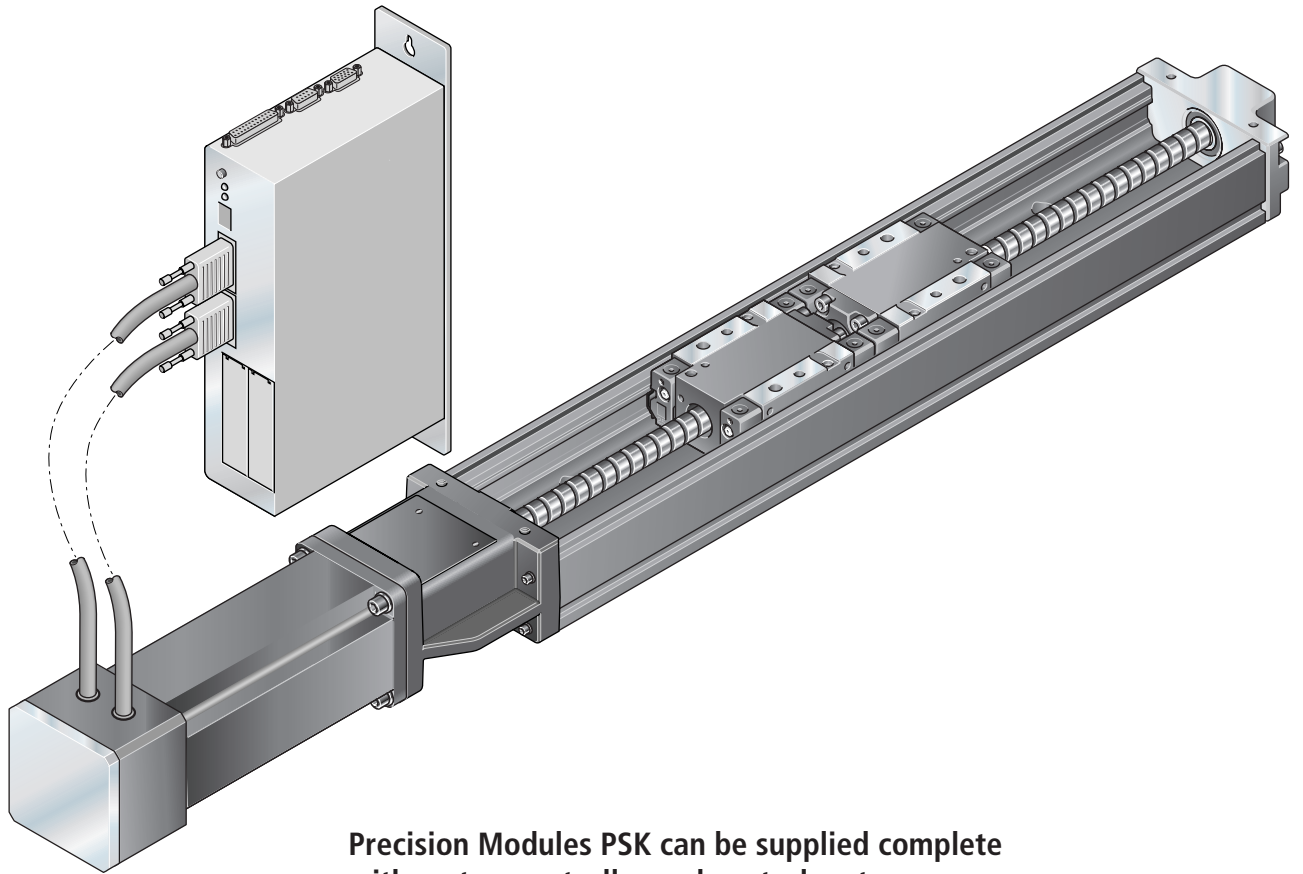

Precision Modules PSK can be supplied complete with motor, controller and control system.

Rexroth – Precision Modules PSK



Types Available, Load Capacities

Type designation (size)

Precision Modules are designated according to **type** and **size**.

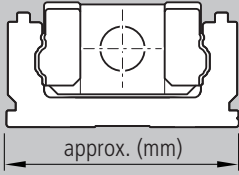
Types also cover the equivalent designs without drive systems.

Precision Module (example) =		Type			Size
		P	S	K	90
System	= Precision Module (P)				
Guideway	= Rail System (S)				
Drive unit	= Precision Ball Screw Assembly (K)				
Frame dimensions	=				

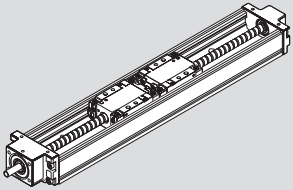
Type	Guideway	Drive Unit	Precision Module
PSK	 Rail System	 Precision Ball Screw Assembly	

Rexroth – Precision Modules

Overview of Precision Modules with permissible loads

Suitable Loads

(recommended value on the basis of past experience)

As far as the desired service life is concerned, loads of up to approximately 20% of the dynamic load and moment values (C , M_v , M_L) have proved acceptable.

The following values may not be exceeded:

- the maximum permissible loads
- the maximum permissible drive torque
- the maximum permissible speed.

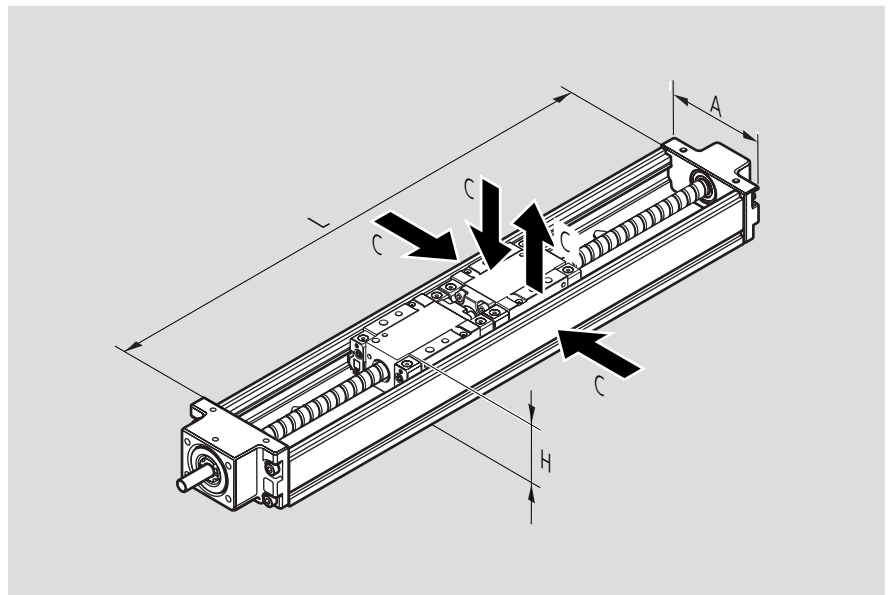

Available lengths

Preferred lengths with reduced delivery times

PSK 50	PSK 60	PSK 90
L (mm)	L (mm)	L (mm)
150	150	340
200	200	440
250	250	540
300	300	640
-	400	740
	500	840
	600	940
	700	

Variable length (customer specific)

Any desired length up to L_{max} can still be supplied on request.

The L_{max} dimensions for the individual types are given in the appropriate sections.

	Precision Module	Dimensions A x H (mm)	Dynamic load capacity C (N)			
			Carriage			
			Standard length		Long	
			1 carr.*	2 carr.	1 carr.	2 carr.
	PSK 50	50 x 26	7 300	11 850	–	–
	PSK 60	60 x 33	7 300	11 850	9 000	14 620
	PSK 90	86 x 46	21 300	34 600	27 500	44 670

Note: All Precision Modules can also be supplied without drive unit.

* carr. = carriage

Rexroth – Precision Modules PSK Structure

PSK without cover

- 1 Fixed bearing end block
- 2 Precision ball screw assembly with zero-clearance cylindrical single nut
- 3 One or two carriages in standard length or long, in steel or aluminum
- 4 Floating bearing end block
- 5 Frame with reference edge and integrated guideway running tracks

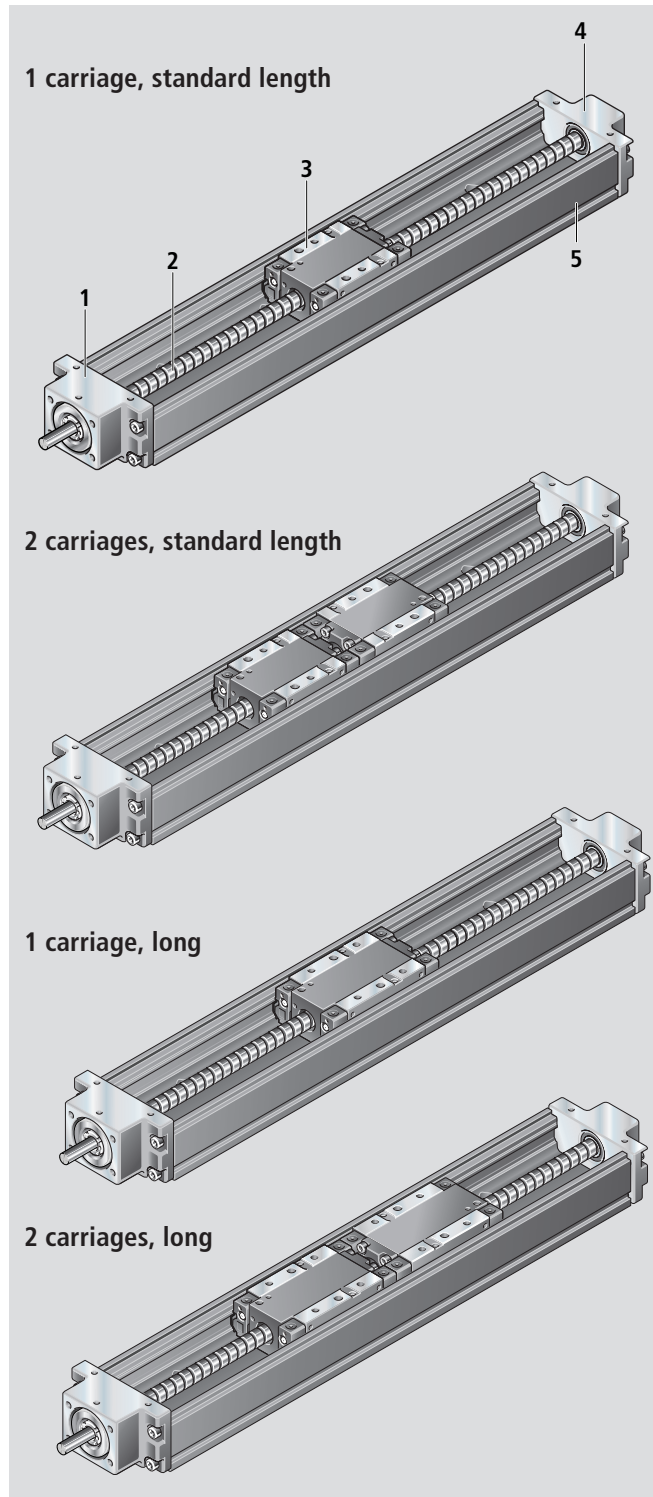

PSK with cover plate

- 9 Cover plate
- 10 One or two carriages in standard length or long
- 10a Carriage plate, aluminum
- 10b Carriage plate guide unit, in steel or aluminum

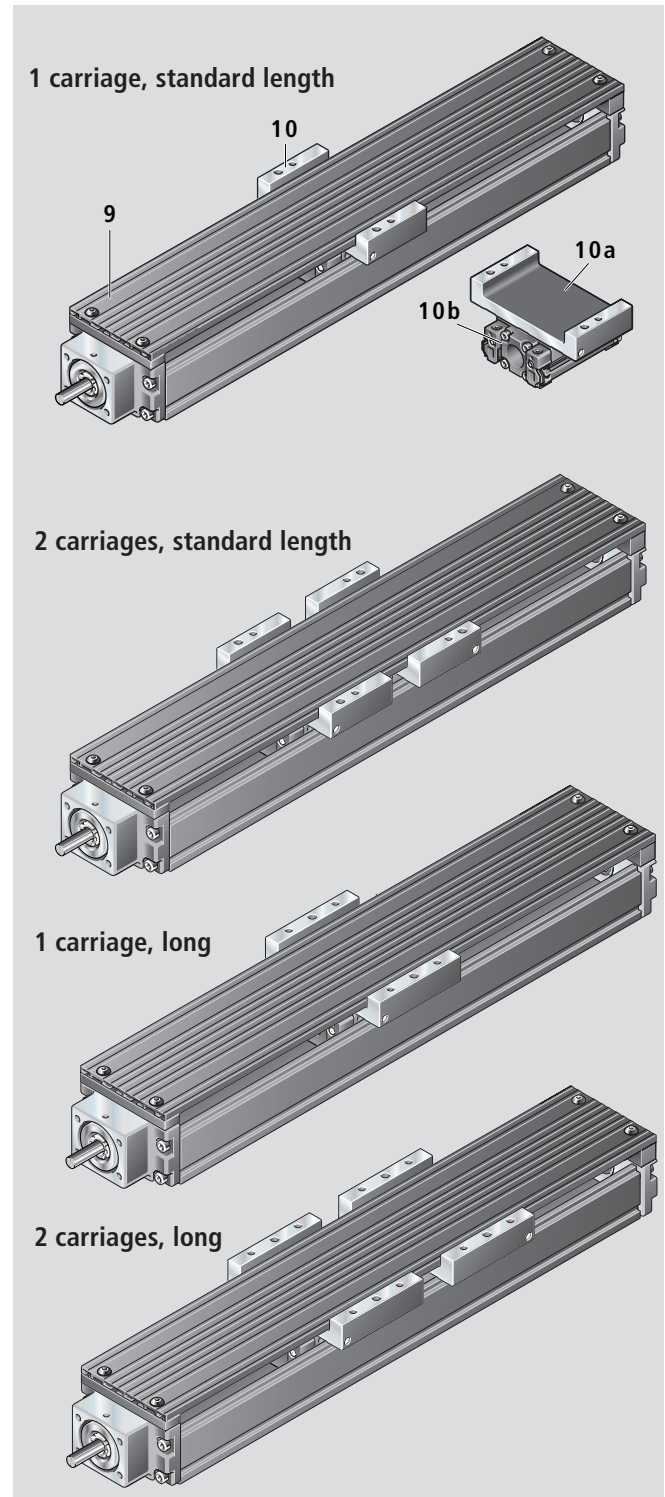

PSK with sealing strip

- 11 Sealing strip, stainless steel
- 12 Carriage, standard length or long
- 12a Carriage plate, aluminum
- 12b Carriage plate guide unit, aluminum

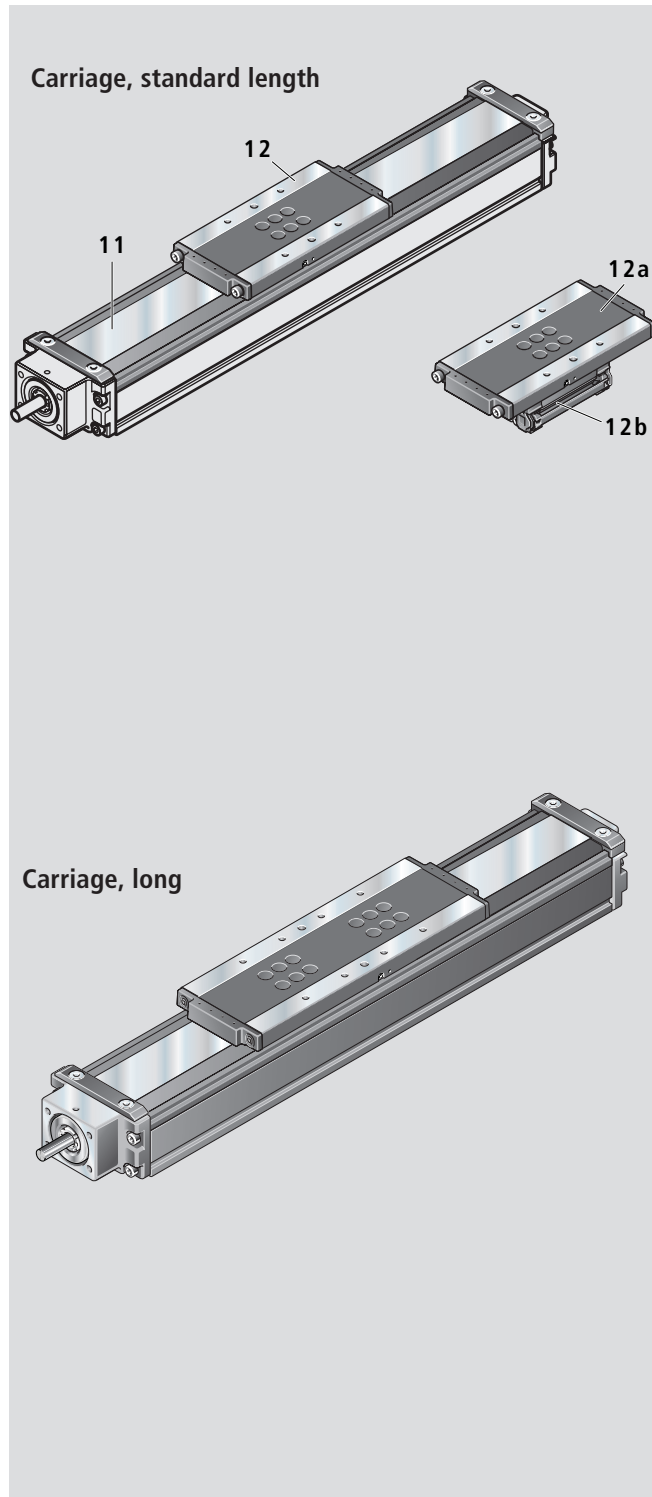

Attachments for all PSK modules

- 6 Switch
- 7 Cable duct
- 8 Switching cam

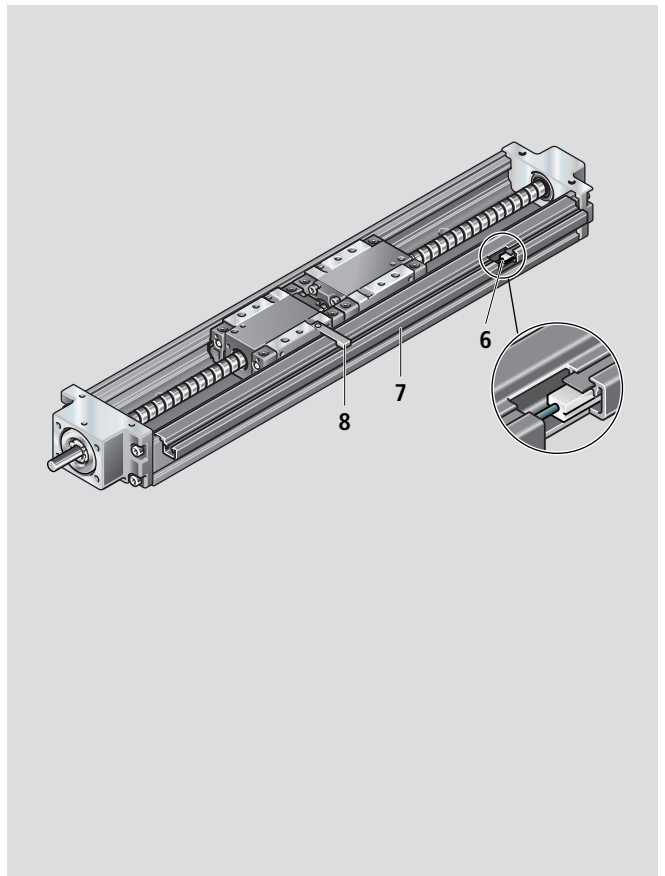

Rexroth – Precision Modules PSK

Structure

Fixed bearing end block

Version with ball screw journal (A)

- 1 End block with preloaded bearing
- 2 Tapped mounting hole
- 3 Centering feature

Version with integrated motor mount (B)

- 1 End block with integrated motor mount and preloaded bearing
- 2 Tapped mounting hole
- 3 Centering feature
- 4 Mount type D, for motor attachment in accordance with NEMA

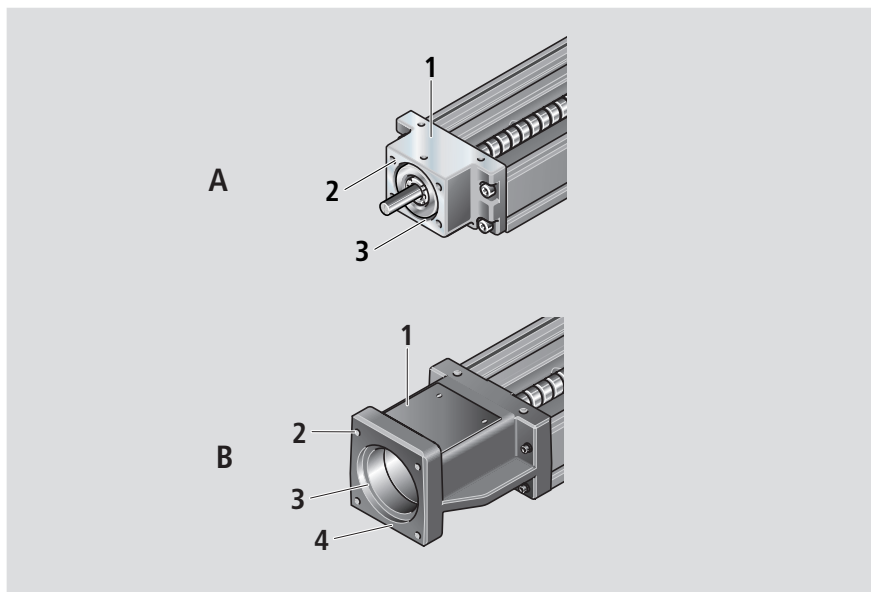

Motor attachment

Motor attachment with mount and coupling

A motor can be attached with a mount and coupling to all Precision Modules equipped with Precision Ball Screw Assemblies.

The motor mount serves both to attach the motor to the Precision Module and as an enclosed housing for the coupling.

The coupling transmits the motor drive torque free of stresses to the Precision Module's ball screw journal.

Fixed bearing end block with integrated motor mount and coupling

- 1 Motor
- 2 Fixed bearing end block with integrated motor mount
- 3 Coupling
- 5 Precision module

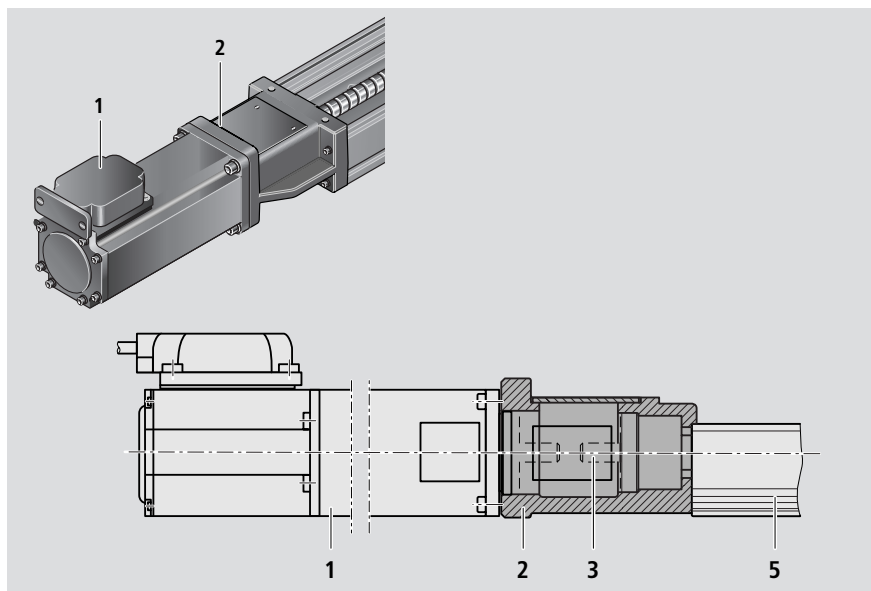

Fixed bearing end block with attached motor mount and coupling

- 1 Motor
- 2 Motor mount
- 3 Coupling
- 4 Fixed bearing end block
- 5 Precision module

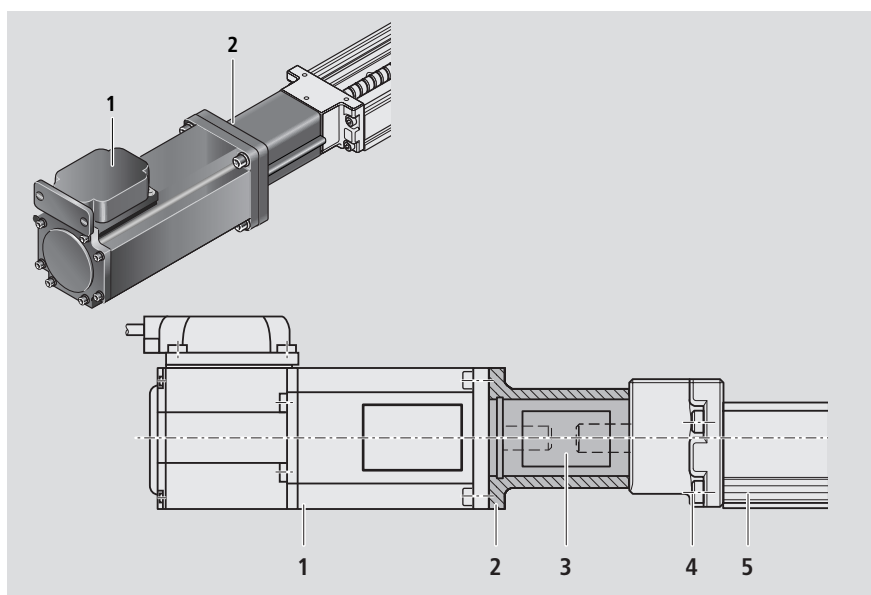

Motor attachment with timing belt

As an alternative, the motor (4) can be attached to the Precision Modules PSK 60 and PSK 90 as a side drive with timing belt (2).

In this case, the overall length is shorter than when a mount and coupling are used to attach the motor.

The compact enclosed housing provides belt protection and secures the motor.

The following gear ratios are available:

$$i = 1 : 1$$

$$i = 1 : 1.5$$

The timing belt side drive can be mounted in four directions:

- top, bottom
- left, right

- 1 Precision module
- 2 Extruded anodized aluminum profile
- 3 Toothed belt
- 4 AC servomotor
- 5 Pre-tensioning of the toothed belt:
Apply pre-tensioning force F_V to the motor (F_V will be specified on delivery).
- 6 Pulleys
- 7 Cover plate
- 8 Cover
- 9 Ball screw journal with support bearing

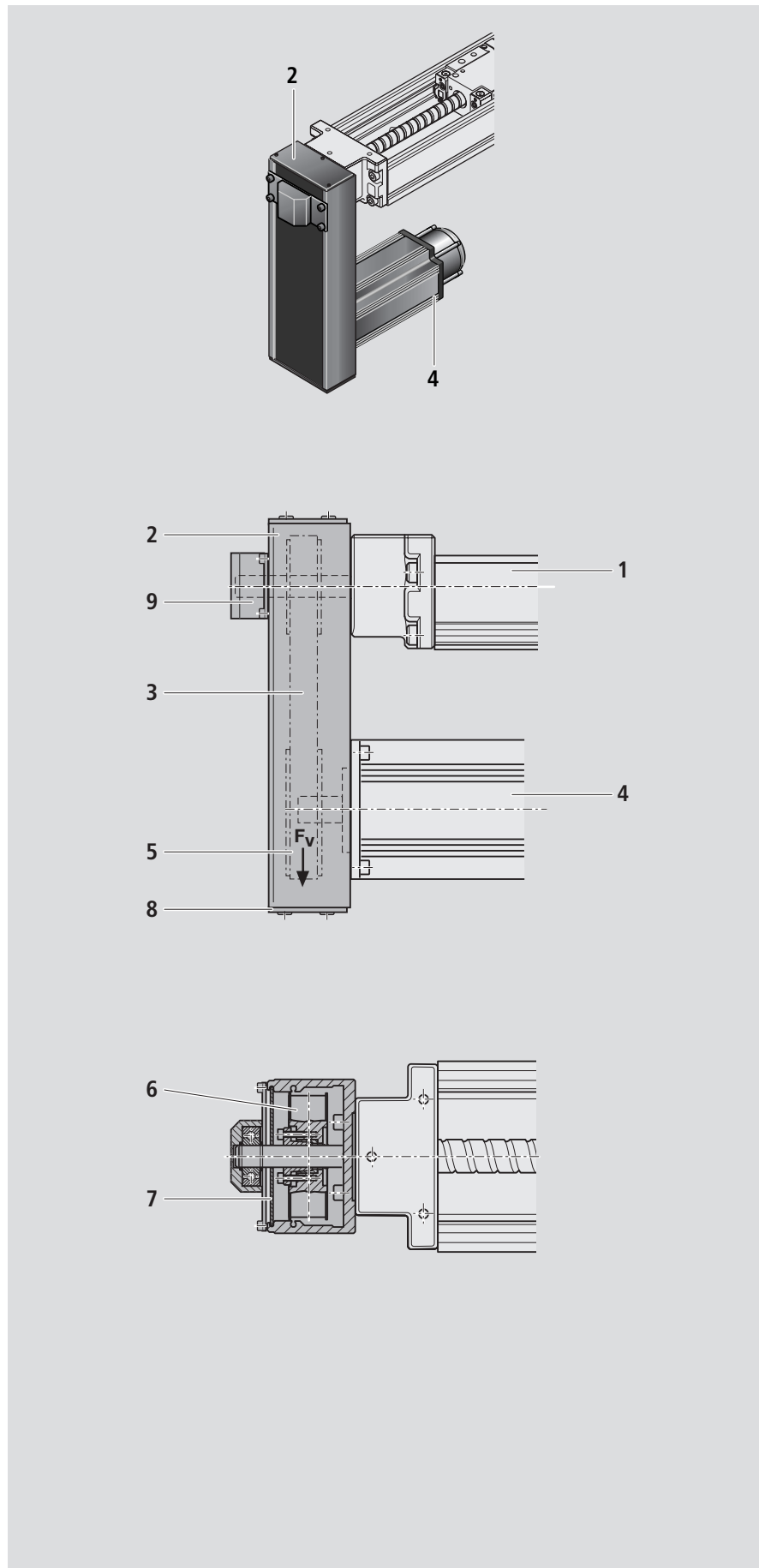

Rexroth – Precision Modules PSK

Technical Data

Dynamic characteristics

Precision module	Type of cover	Carriage length	No. of carriages	Guideway			Ball screw		Fixed bearing
				Dynamic load capacity C (N)	Dynamic moments		d ₀ x P	Dynamic load capacity C (N)	Dynamic load capacity C (N)
					M _t (Nm)	M _L (Nm)			
PSK 50	w/o and plate	standard	1 carr.*	7 300	150	35	8 x 2.5	2 200	1 600
			2 carr.	11 850	244	5.93 · l _m			
	strip	standard	1 carr.	7 300	150	35			
		long	1 carr.	11 850	244	356			
PSK 60	w/o and plate	standard	1 carr.	7 300	170	35	12 x 2	2 240	4 000
			2 carr.	11 850	276	5.93 · l _m			
		long	1 carr.	9 000	210	60	12 x 5	3 800	
			2 carr.	14 620	341	7.31 · l _m			
	strip	standard	1 carr.	9 000	210	60	12 x 10	2 500	
		long	1 carr.	14 620	341	541			
PSK 90	w/o and plate	standard	1 carr.	21 300	710	150	16 x 5	12 300	13 400
			2 carr.	34 600	1 153	17.3 · l _m			
		long	1 carr.	27 500	910	270	16 x 10	9 600	
			2 carr.	44 670	1 478	22.34 · l _m			
	strip	standard	1 carr.	21 300	710	150	16 x 16	6 300	
			2 carr.	34 600	1 153	1 557			
		long	1 carr.	21 300	710	150			
			2 carr.	34 600	1 153	1 557			

* carr. = carriage

l_m = center-to-center distance between carriages in mm

General technical data

Precision module	Planar moment of inertia		Max. length L _{max} (mm)	Min. c-to-c distance l _{m min} (mm)		Mass (kg)			
	I _x (cm ⁴)	I _y (cm ⁴)		standard length	long	without cover without motor	without cover with motor	with cover plate	with sealing strip
PSK 50	1.69	13.5	600	60	-	0.0035 · L + m _b	0.0038 · L + 0.179 + m _b	0.0041 · L + 0.204 + m _b	0.0042 · L + 0.208 + m _b
PSK 60	5.38	34.48	940	60	75	0.0062 · L + m _b	0.0069 · L + 0.254 + m _b	0.0072 · L + 0.281 + m _b	0.0073 · L + 0.272 + m _b
PSK 90	22.34	145.8	940	90	110	0.0125 · L + m _b	0.0138 · L + 0.638 + m _b	0.0146 · L + 0.726 + m _b	0.0147 · L + 0.736 + m _b

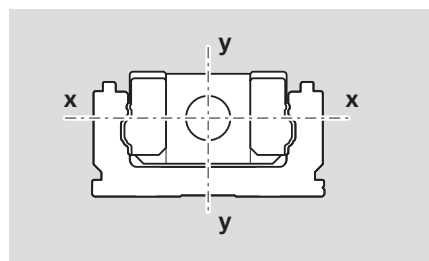

Mass

Mass calculation does not include motor or switches.

Mass formula:

Mass (kg/mm) x length L (mm) + mass of all parts of fixed length (kg) + moved mass m_b (kg)

Modulus of elasticity E

$$E = 210,000 \text{ N/mm}^2$$

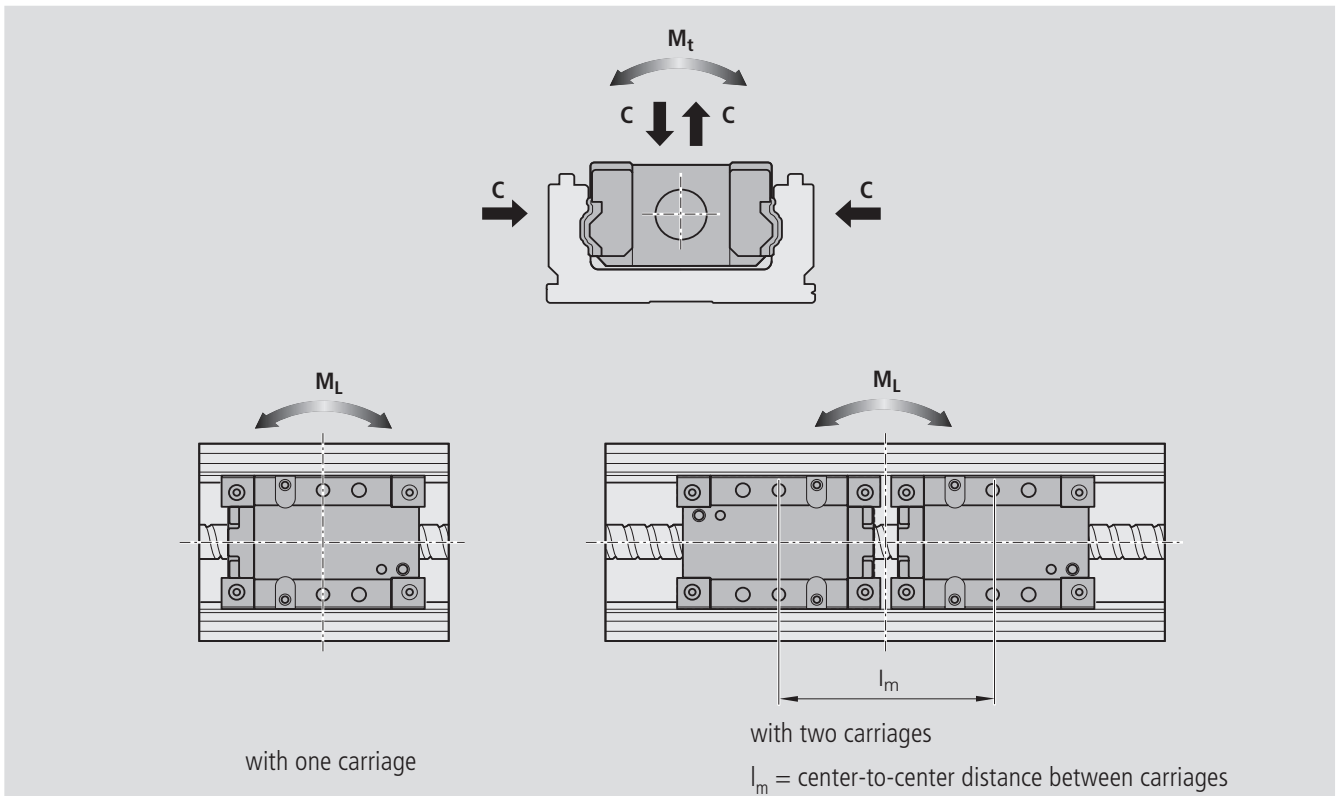

Notes on dynamic load capacities and moments

The dynamic load capacities and moments are based on 100,000 m travel. However, a travel of just 50,000 m is often taken as a basis. If this is the case, for comparison purposes: Multiply value **C**, **M_t** and **M_L** from the Rexroth table by 1.26.

Maximum permissible loads

The maximum permissible forces and moments are equal to half the dynamic characteristics (**C**, **M_t**, **M_L**).

Moved mass m_b

* carr. = carriage

Precision module	Carriage version	Carriage length	Moved mass m _b (kg)						
			without cover without motor		without cover with motor		with cover plate		with sealing strip
			1 carr.*	2 carr.	1 carr.	2 carr.	1 carr.	2 carr.	1 carr.
PSK 50	Steel version	standard	0.20	0.40	0.22	0.42	0.29	0.56	-
	Al version	standard	0.11	0.21	0.12	0.23	0.19	0.37	0.20
		long	-	-	-	-	-	-	0.37
PSK 60	Steel version	standard	0.25	0.49	0.27	0.52	0.38	0.73	-
		long	0.34	0.69	0.37	0.71	0.51	1.00	-
	Al version	standard	0.12	0.24	0.15	0.27	0.25	0.48	0.33
long		0.17	0.33	0.19	0.36	0.33	0.64	0.58	
PSK 90	Steel version	standard	0.77	1.54	0.85	1.62	1.09	2.10	-
		long	1.04	2.08	1.11	2.15	1.43	2.79	-
	Al version	standard	0.38	0.76	0.46	0.84	0.70	1.32	0.80
long		0.49	0.98	0.57	1.06	0.89	1.70	1.40	

Rexroth – Precision Modules PSK

Technical Data

Maximum permissible drive torque M_{per}

The M_{per} values shown apply in the following conditions:

- horizontal operation
- ball screw journal without keyway
- no radial load on ball screw journal

Observe the rated torque of coupling used!

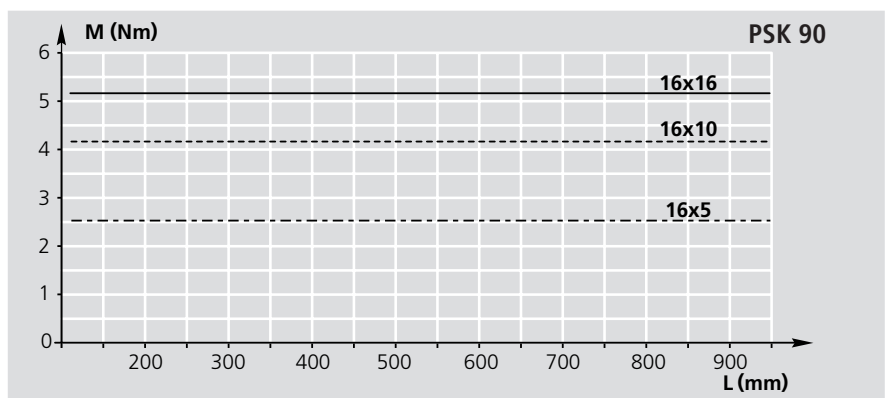
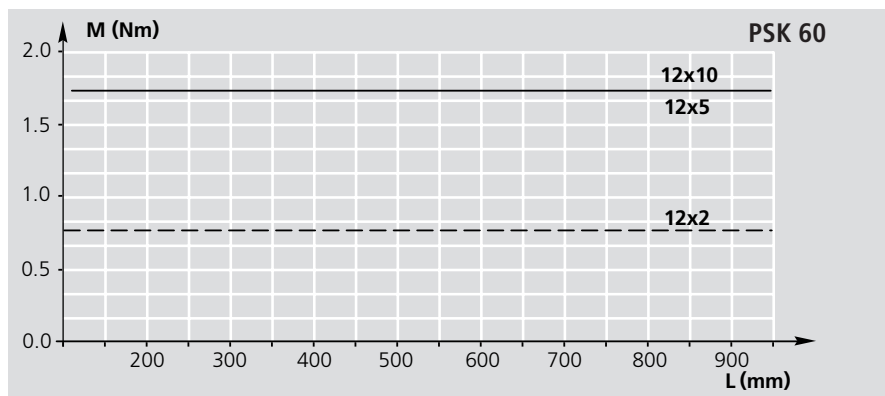
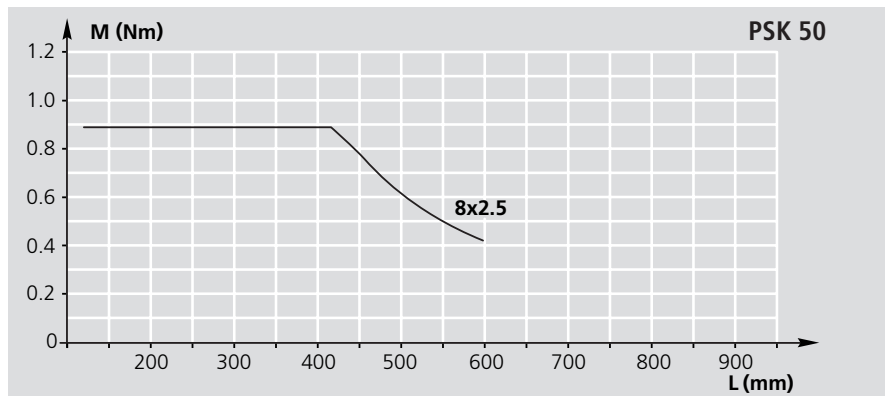

Ball screw journal with keyway

Due to the notch effect and the reduction of the effective diameter, observe the maximum values for the drive torque given in the graphs!

For PSK 90:

If a keyway is used, the applicable value will be the lower figure when comparing the graph and the table!

Precision Module	M_{per} (Nm)
PSK 90	3.2

Permissible velocity v

Observe the motor speed!

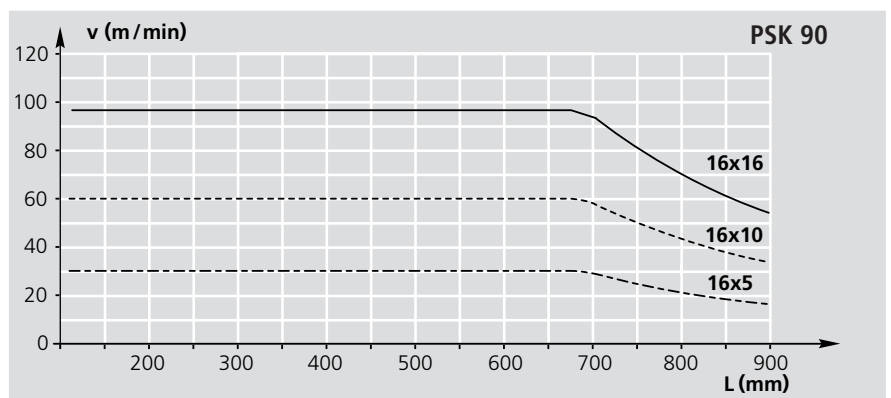
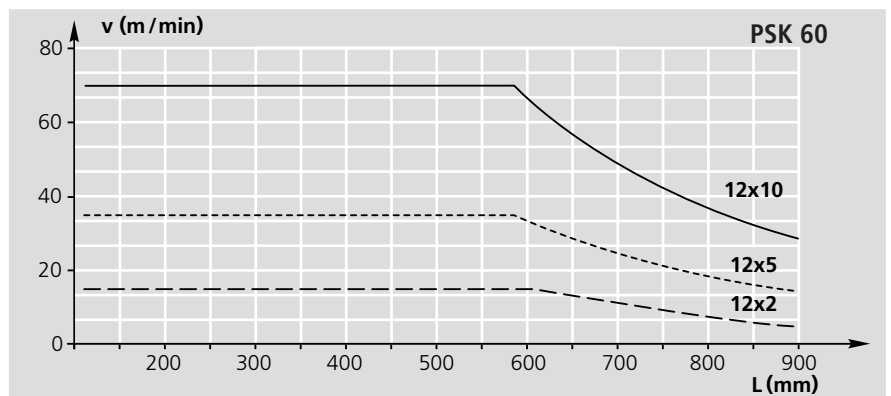
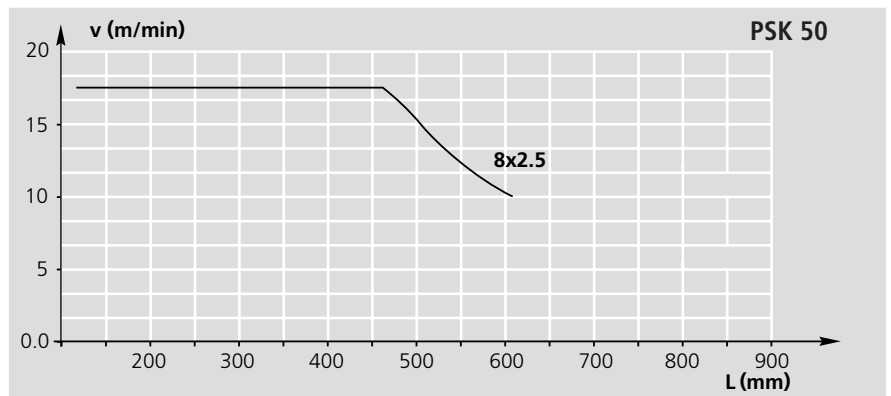

Rexroth – Precision Modules PSK

Technical data

Drive data of side drive with timing belt, fixed bearing end

for motor attachment via timing belt side drive

Motor type		MKD 25B / MSM 030B / MSM 030C					MKD 41B / MSM 040B					
Friction moment M_{RRV} (Nm)		0.35					0.4					
		Permissible torque up to length L = ... at			Reduced mass moment of inertia at		Permissible torque up to length L = ... at			Reduced mass moment of inertia at		
Reduction $i = \dots$			$i = 1$	$i = 1.5$	$i = 1$	$i = 1.5$		$i = 1$	$i = 1.5$	$i = 1$	$i = 1.5$	
Precision module	Ball screw $d_0 \times P$	L (mm)	M_{Rv} (Nm)	M_{Rv} (Nm)	J_{Rv} (10^{-6} kgm ²)	J_{Rv} (10^{-6} kgm ²)	L (mm)	M_{Rv} (Nm)	M_{Rv} (Nm)	J_{Rv} (10^{-6} kgm ²)	J_{Rv} (10^{-6} kgm ²)	
PSK 60	12 x 2	940	0.80	0.50	45.6	17.7						
	12 x 5	940	1.60	1.10								
	12 x 10	940	1.60	1.10								
PSK 90	16 x 5	940	2.40	1.60	40.0	14.0	940	2.40	1.60	234	98.9	
	16 x 10	940	2.50	1.70			940	3.90	2.60			
	16 x 16	940	2.50	1.70			940	4.80	3.20			

M_{Rv} = Permissible system torque for side drive with timing belt on the motor journal (observe max. motor torque M_{max})

M_{RRV} = Friction moment, side drive with timing belt on motor journal

J_{Rv} = Reduced mass moment of inertia, side drive with timing belt

i = Reduction, side drive with timing belt

Technical data, AC servomotors

Motor type		MKD 25B-144 KG1	MKD 41B-144 KG1
Maximum effective speed n_{max}	(min ⁻¹)		
Rated torque M_N	(Nm)	0.9	2.7
Maximum torque M_{max}	(Nm)		
Mass moment of inertia $J_M + J_{Br}$	(10^{-6} kgm ²)	30 + 8	170 + 16
Braking torque M_{Br}	(Nm)	1.0	2.2
Mass with brake m_{Br}	(kg)	2.25	4.65

See catalog "Controllers, Motors, Electrical Accessories, Servomotors" 82 710.

Technical data, ECODRIVE Cs motors

Motor type		MSM 030 B	MSM 030 C	MSM 040 B
Maximum effective speed n_{max}	(min ⁻¹)	3 000	3 000	3 000
Rated torque M_N	(Nm)	0.64	1.30	2.40
Maximum torque M_{max}	(Nm)	1.91	3.80	7.10
Mass moment of inertia $J_M + J_{Br}$	(10^{-6} kgm ²)	10 + 3	17 + 3	67 + 8
Braking torque M_{Br}	(Nm)	1.27	1.27	2.45
Mass, motor + brake $m_M + m_{Br}$	(kg)	0.96 + 0.4	1.5 + 0.4	3.1 + 0.7

Friction moment M_R at motor journal

Precision module	Ball screw $d_0 \times P$	Friction moment M_R (Nm) for carriage version			
		without cover or with cover plate 1 or 2 carriages		with sealing strip 1 carriage	
		Standard length	Long	Standard length	Long
PSK 50	8 x 2.5	0.10	–	0.10	0.11
PSK 60	12 x 2	0.12	0.12	0.12	0.13
	12 x 5	0.13	0.14	0.14	0.15
	12 x 10	0.15	0.16	0.16	0.18
PSK 90	16 x 5	0.30	0.31	0.30	0.31
	16 x 10	0.30	0.33	0.32	0.35
	16 x 16	0.31	0.37	0.34	0.39

Mass moment of inertia J_s for system with external load

$$J_s = [k_1 + k_2 \cdot L + k_3 (m_b + m_{fr})] \cdot 10^{-6}$$

J_s mass moment of inertia for system with external load (kgm²)

k_1, k_2, k_3 Constants, (see table)

m_b Moved mass (kg) (see "Technical Data")

m_{fr} External load (kg)

L Length of PSK module (mm)

Precision module	Ball screw $d_0 \times P$	Constants		
		k_1	k_2	k_3
PSK 50	8 x 2.5	0.485	0.002	0.158
PSK 60	12 x 2	0.971	0.013	0.101
	12 x 5	0.959	0.011	0.633
	12 x 10	0.959	0.011	2.533
PSK 90	16 x 5	3.678	0.031	0.633
	16 x 10	3.678	0.031	2.533
	16 x 16	3.702	0.034	6.485

Coupling data

Precision module	for motor attachment	Coupling data		
		Rated torque M_k (Nm)	Mass moment of inertia J_k (10 ⁻⁶ kgm ²)	Weight (kg)
PSK 50	MSM 030B	3.70	7.00	0.075
	MSI 032	1.90	1.20	0.014
	MSM 020B			
PSK 60	MSM 030B	3.70	7.00	0.075
	MKD 25	1.90	1.20	0.014
	MSI 040			
PSK 90	MKD 41	9.00	61.00	0.260
	MSM 040B			
	MKD 25	10.00	35.00	0.170
	MSM 030C			
	MSI 055			

Rexroth – Precision Modules PSK

Technical Data, Design Calculations

Nominal service life

Nominal service life in meters: $L_{10} = \left(\frac{C}{F_m} \right)^3 \cdot 10^5$	L_{10} = Nominal service life in meters (m)
Nominal service life in hours: $L_{10h} = \frac{L_{10}}{60 \cdot v}$	L_{10h} = Nominal service life in hours (h)
	C = Dynamic load capacity (N)
	F_m = Mean equivalent dynamic load (N)
	v = Velocity (from "Permissible velocity" graph) (m/min)

Friction moment

Motor attachment via mount and coupling

$M_R = M_{RS}$	M_R = Friction moment at motor journal (Nm)
	M_{RS} = Friction moment, system (Nm)
	M_{RRV} = Friction moment, side drive with timing belt at motor journal (Nm)
	i = Reduction

Motor attachment via side drive with timing belt

$$M_R = \frac{M_{RS}}{i} + M_{RRV}$$

Mass moment of inertia

For handling: $6 \cdot J_M \geq J_{fr}$	J_{fr} = External mass moment of inertia (kgm ²)
For processing: $1.5 \cdot J_M \geq J_{fr}$	J_M = Mass moment of inertia of motor (kgm ²)

Motor attachment via mount and coupling

$J_{fr} = J_S + J_K + J_{Br}$	J_{tot} = Total mass moment of inertia (kgm ²)
$J_{tot} = J_{fr} + J_M = J_S + J_K + J_{Br} + J_M$	J_{fr} = External mass moment of inertia (kgm ²)
	J_S = Mass moment of inertia of system with external load (kgm ²)
	J_K = Mass moment of inertia of coupling (kgm ²)
	J_{Br} = Mass moment of inertia of motor brake (kgm ²)
	J_M = Mass moment of inertia of motor (kgm ²)
	J_{RV} = Reduced mass moment of inertia of side drive with timing belt at motor journal (kgm ²)
	L = Length of PSK module (mm)
	i = Reduction

Motor attachment via side drive with timing belt

$$J_{fr} = \frac{J_S}{i^2} + J_{RV} + J_{Br}$$

$$J_{tot} = J_{fr} + J_M = \frac{J_S}{i^2} + J_{RV} + J_M + J_{Br}$$

Speed

If a geared motor is attached, the moment of inertia of the gears and the gear transmission ratio must be included in the design calculation.

$n_1 = \frac{i \cdot v \cdot 1000}{P}$	v = Permissible velocity (m/min)
$n_1 < n_{max}$	n_1 = Speed (1/min)
$v < \text{permissible velocity from graph}$	n_{max} = Maximum effective motor speed (1/min)
	P = Screw lead (mm)
	i = Reduction

Rexroth – Precision Modules PSK

Calculation Example

Starting data

A mass of 20 kg is to be moved 390 mm at a maximum velocity of 40 m/min.

Module selected on the basis of the technical data and mounting dimensions:

PSK 90 without cover and with a standard length steel carriage; motor attachment via integrated mount and coupling; motor type MSI 055 with brake.

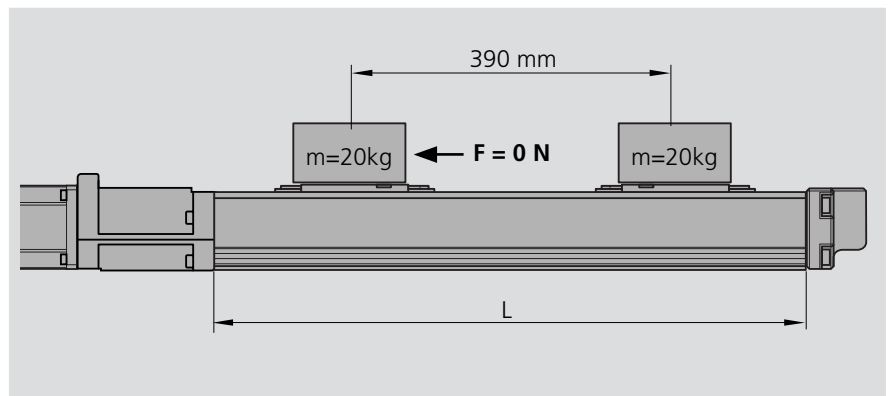

When dimensioning the drive, the motor-controller combination must always be considered, because the motor type and the performance data (e.g. max. effective speed and maximum torque) depend on the controller or the control system used.

Estimation of PSK module length L:

Excess travel = $2 \cdot P = 2 \cdot 16 \text{ mm} = 32 \text{ mm}$ (in accordance with the formula given in "PSK 90 Components and Ordering Data")

Selection of ball screw assembly:

Permissible ball screw assemblies according to "permissible velocity" graph at $v = 40 \text{ m/min}$: ball screw 16 x 10 and 16 x 16

Ball screw assembly selected: **ball screw 16 x 10** with $v_{\text{max}} = 60 \text{ m/min}$

Generally, the smallest lead should be preferred (resolution, braking path, length).

Permissible drive torque of ball screw 16 x 10: $M_{\text{per}} = 4.1 \text{ Nm}$ (according to "permissible drive torque" graph)

Calculating the PSK module length L:

Excess travel = $2 \cdot P = 2 \cdot 10 \text{ mm} = 20 \text{ mm}$

Length $L = (\text{stroke} + 2 \cdot \text{excess travel}) + 100 \text{ mm} = (390 \text{ mm} + 2 \cdot 20 \text{ mm}) + 100 \text{ mm} = 530 \text{ mm}$

Selected: preferred length **$L = 540 \text{ mm}$** ; hole spacing in frame: 70 mm / 4 x 100 mm / 70 mm

Friction moment M_R : $M_R = M_{RS} = 0.30 \text{ Nm}$ (see "Technical Data")

Mass moment of inertia J: $J_{\text{fr}} = J_S + J_K + J_{Br}$

$J_K = 35 \cdot 10^{-6} \text{ kgm}^2$; $J_{Br} = 3 \cdot 10^{-6} \text{ kgm}^2$ (see "Technical Data" and "Motors")

$J_S = [k_1 + k_2 \cdot L + k_3 \cdot (m_b + m_{fr})] \cdot 10^{-6}$; $m_b = 0.77 \text{ kg}$ (see "Technical Data")

$J_S = [3.678 + 0.031 \cdot 540 \text{ mm} + 2.533 \cdot (0.77 \text{ kg} + 20 \text{ kg})] = 73.03 \cdot 10^{-6} \text{ kgm}^2$

$J_{\text{fr}} = (73.03 + 35 + 3) \cdot 10^{-6} \text{ kgm}^2 = 111.03 \cdot 10^{-6} \text{ kgm}^2$

For handling: $J_M \geq \frac{J_{\text{fr}}}{6} = \frac{111.03 \cdot 10^{-6} \text{ kgm}^2}{6} = 18.5 \cdot 10^{-6} \text{ kgm}^2$

Speed: $n = \frac{i \cdot v \cdot 1000}{P} = \frac{1 \cdot 40 \text{ m/min} \cdot 1000}{10 \text{ mm}} = 4000 \text{ min}^{-1}$

Result:

PSK 90 without cover with one steel carriage in standard length:

Motor MSI 055, attachment via integrated mount and coupling

Preferred length $L = 540 \text{ mm}$; hole spacing in frame: 70 mm / 40 x 100 mm / 70 mm

Ball screw 16 x 10 with $v_{\text{max}} = 60 \text{ m/min}$ and $M_{\text{per}} = 4.1 \text{ Nm}$

Friction moment $M_R = 0.30 \text{ Nm}$

Motor data: Mass moment of inertia: $J_M = 29 \cdot 10^{-6} \text{ kgm}^2 > 18.5 \cdot 10^{-6} \text{ kgm}^2$

Speed: $n_M = 7000 \text{ min}^{-1} > 4000 \text{ min}^{-1}$

Torque: $M_M = 3.0 \text{ Nm} < 4.1 \text{ Nm}$

For final motor selection, the drive and performance data have to be recalculated as specified in the catalogs "Controls, Motors, Electrical Accessories, ..." 82 710 and 82 720.

Rexroth – Precision Modules PSK

Accuracy

General Note

All accuracy figures apply to the module when screwed down and assume an ideally flat mounting base. The figures do not take account of any shape deviations in the mounting base surface.

Accuracy P_1



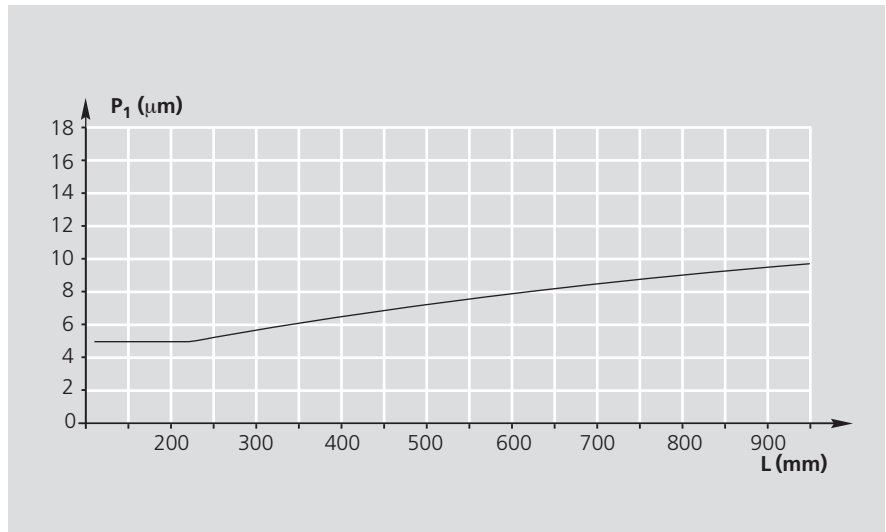
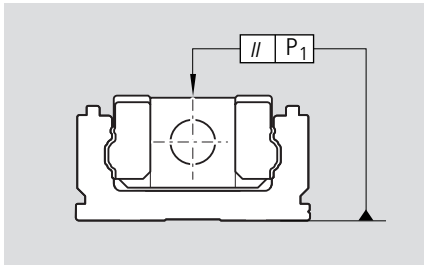

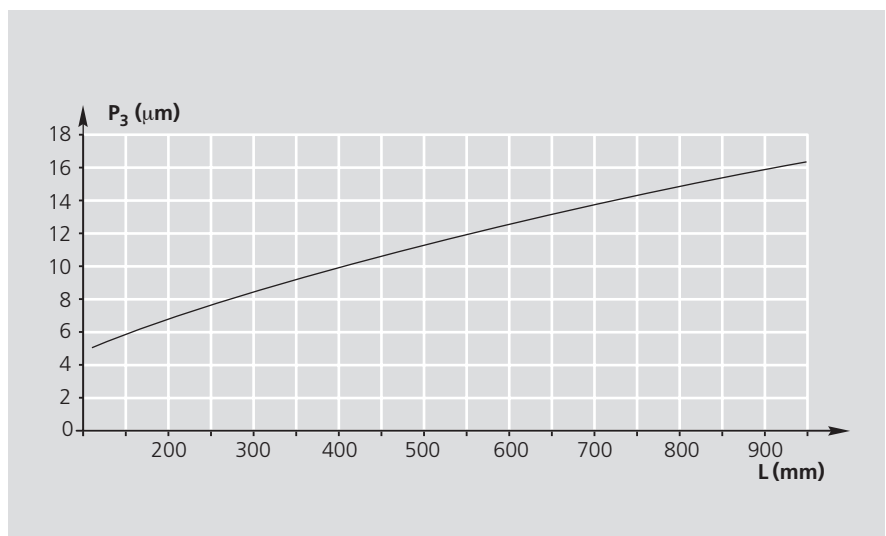
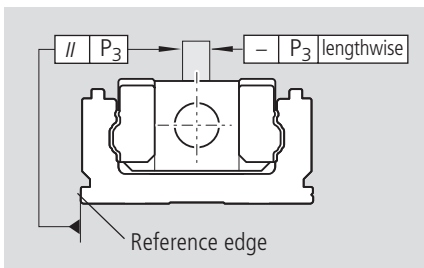

Measured at the carriage center

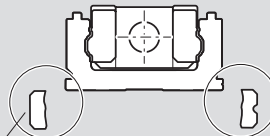

Accuracy P_3

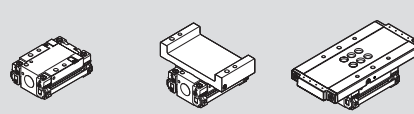

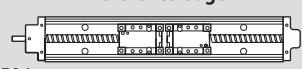
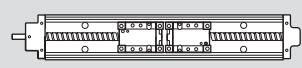
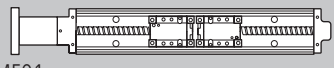
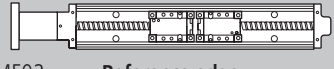
STAR – Precision Module PSK 50 Components and Ordering Data

Part number, length 1465-200-00, ... mm  Reference edge	... Type (and dimension drawing)	Guide- way = .. 	Drive unit = .. 		Carriage = .. 								
			Screw journal	Ball screw size $d_0 \times P$ 8 x 2.5	For cover option	Steel		Aluminum					
						Standard length 1 carr.*	2 carr.	Standard length 1 carr.	2 carr.	Long 1 carr.			
without drive (OA)  OA01	OA01	Length = L ① L = 150 mm ⑩ L = 200 mm ⑪ L = 250 mm ⑫ L = 300 mm ⑬	without screw journal	⑤0	without cover	①	②	⑪	⑫	--			
with ball screw, without motor mount (OF) Reference edge  OF01  OF02 Reference edge	OF01 OF02 (14.26.00)		without cover	①	②	⑪	⑫	--	cover plate	⑫	--		
	with ball screw and motor mount (MF) Reference edge  MF01  MF02 Reference edge		MF01 MF02 (14.26.11) (14.26.12)	cover plate	②1	②2	③1	③2		--	sealing strip	--	④1
			with ball screw and integrated motor mount (MF) MF10 MF11 Reference edge  Reference edge  Reference edge	MF10 MF11 (14.26.16) (14.26.17) (14.26.18)	without cover	①	②	⑪		⑫		--	cover plate
dia. 5	①			cover plate	②1	②2	③1	③2	--	sealing strip	--	④1	
				without cover	①	②	⑪	⑫	--		cover plate	⑫	
cover plate	②1		②2	③1	③2	--	sealing strip	--	④0	--		④1	
sealing strip	--		--	④0	--	④1							
without cover	①		②	⑪	⑫	--	cover plate	⑫	--	sealing strip	--	④1	
cover plate	②1		②2	③1	③2	--		sealing strip	--		④0	--	④1
sealing strip	--		--	④0	--	④1							

For order example see "Inquiry/Order Form" section.

* carr. = carriage

Switch mounting arrangements

A cable duct is required to mount the switches.

For more information on switch mounting and switch types, see the section on "Switch Mounting Arrangements".

Please check whether the selected combination is a permissible one (load capacities, moments, maximum speed, motor data, etc.)!

Motor attachment = ..		Motor = ..		Cover = ..			1st, 2nd, 3rd switch = ..	Documentation = ..		
Gear ratio i =	Attachment kit ¹⁾	for motor	Motor type	with-out cover	with cover plate	with sealing strip	Cable duct = ..	Switching cam = ..	Standard report	Measurement report
	00	--	00	00						
	00	--	00	00	00	--	without switch and cable duct 00		01	02 Friction moment
				00	01	--	Switch: Reed contact 21 - ...			03 Lead deviation
				00	--	02	Hall sensor 22 - ...			04 Running accuracy
	01	MSM 030B	71 70 ²⁾	00	--	--	Switch type Mounting side			05 Positioning accuracy
	02	VRDM 368	27	00	01	--	Cable duct 26			
				00	--	02	Switching cam for: - without cover 32 - with cover plate			
	31	NEMA 17-D	00	00	--	--	Switching cam for sealing strip 34			
	33	MSI 032	77 76 ²⁾	00	01	--				
	34	MSM 020B	69 68 ²⁾	00	--	02				

1) Attachment kit can also be supplied without motor (enter "00" for motor on order form).
 2) Motor without brake

Mounting side for switches:
 Switches may be mounted on the left (L) or right (R) side of the Precision Module.

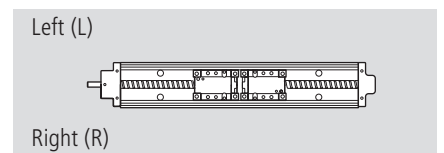

Rexroth – Precision Module PSK 50

Lengths and Hole Spacing

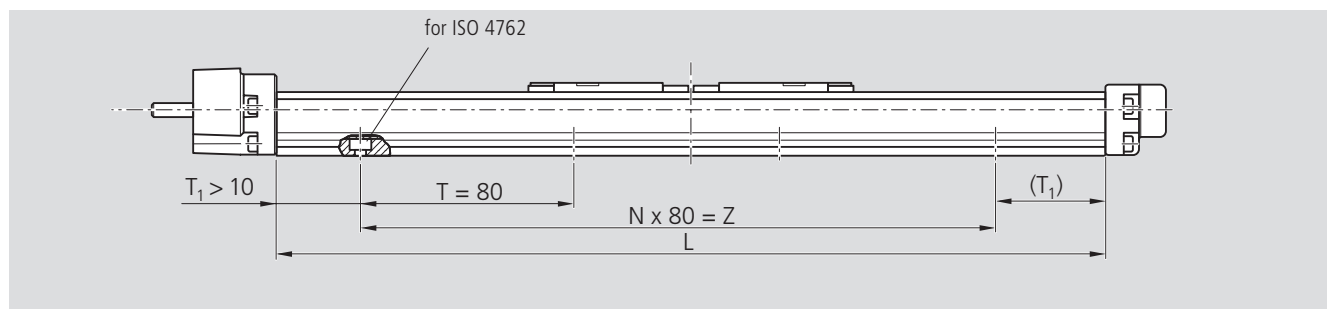

Length L

	Number of carriages	Carriage version	
		Standard length	Long
without cover and with cover plate	one carriage	$L = (\text{stroke} + 2 \cdot \text{excess travel}) + 70 \text{ mm}$	
	two carriages	$L = (\text{stroke} + 2 \cdot \text{excess travel}) + l_m + 70 \text{ mm}$ $l_{m \text{ min}} = 60 \text{ mm}$	
with sealing strip	one carriage	$L = (\text{stroke} + 2 \cdot \text{excess travel}) + 127 \text{ mm}$	$L = (\text{stroke} + 2 \cdot \text{excess travel}) + 187 \text{ mm}$

l_m = center-to-center distance between carriages (observe $l_{m \text{ min}}$)
 Stroke = maximum travel of carriage center between the outermost switch activation points.

In most cases the recommended limit for excess travel (braking path) is:

Excess travel = $2 \cdot \text{screw lead } P$
 Example:
 Ball screw 8×2.5 ($d_0 \times P$),
 Excess travel = $2 \cdot 2.5 = 5 \text{ mm}$

Preferred lengths of frame

Length L	T_1	T	N	Z	for ISO 4762 screws
150	35	80	1	80	M4
200	20	80	2	160	
250	45	80	2	160	
300	30	80	3	240	

Variable length

$$N_1 = \frac{L}{T} = \frac{L}{80}$$

$$N = \text{INT}(N_1) \text{ (whole number of } N_1)$$

$$T_1 = \frac{L - T \cdot N}{2} = \frac{L - 80 \cdot N}{2}$$

$T_1 > T_{1 \text{ min}} \rightarrow N, T_1$
 $T_1 \leq T_{1 \text{ min}} \rightarrow N = N - 1$
 $T_1 = T_1 + 40 \text{ mm}$

Result:
 Hole pattern: $T_1 / N \cdot 80 / T_1$

Example:
 $L = 260 \text{ mm}$

$$N_1 = \frac{L}{T} = \frac{260}{80} = 3.25$$

$$N = 3$$

$$T_1 = \frac{260 - 80 \cdot 3}{2} = 10$$

$$T_1 \leq T_{1 \text{ min}} \rightarrow N = 3 - 1 = 2$$

$$T_1 = 10 + 40 = 50$$

Result:
 50 mm / 2 · 80 mm / 50 mm

Calculating the hole pattern for the frame

Applies to all cover options

Precision module length L (mm)
 Hole spacing T = 80 mm
 Minimum end space $T_{1 \text{ min}} = 10 \text{ mm}$

Rexroth – Precision Module PSK 50

Dimension Drawings without Cover

All dimensions in mm

Diagrams to different scales

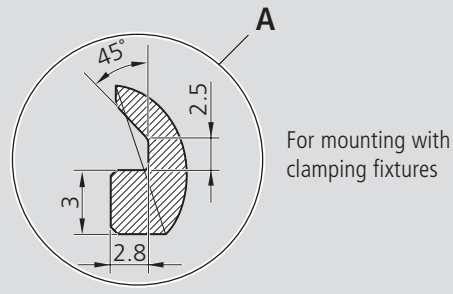
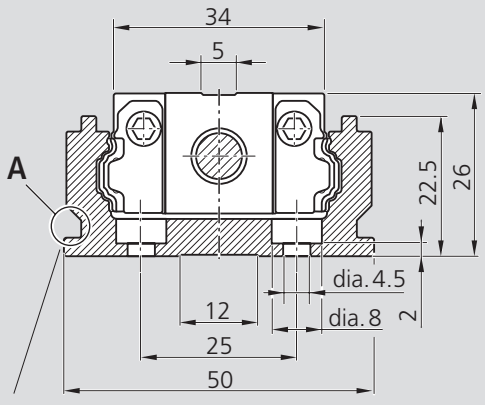
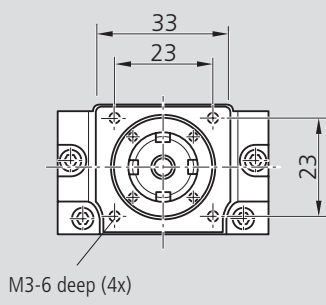
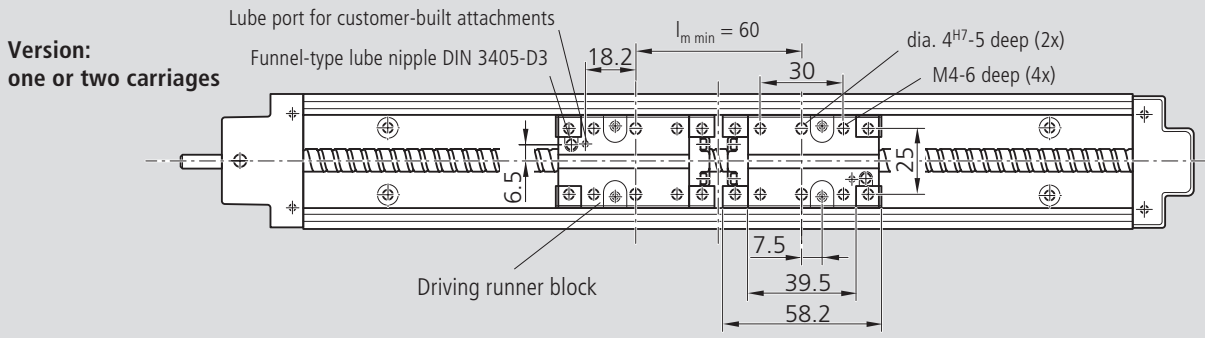
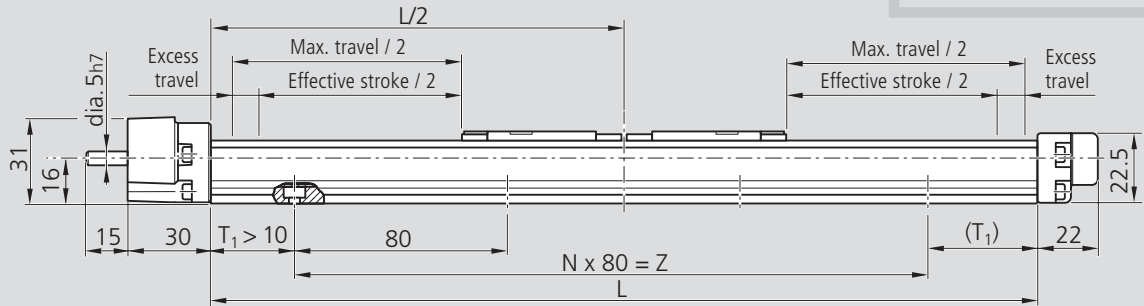
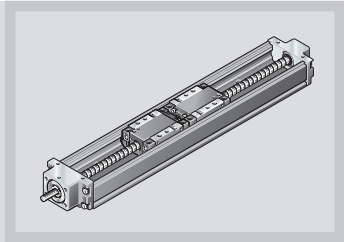

Reference edge

Rexroth – Precision Module PSK 50

Dimension Drawings with Cover Plate

All dimensions in mm

Diagrams to different scales

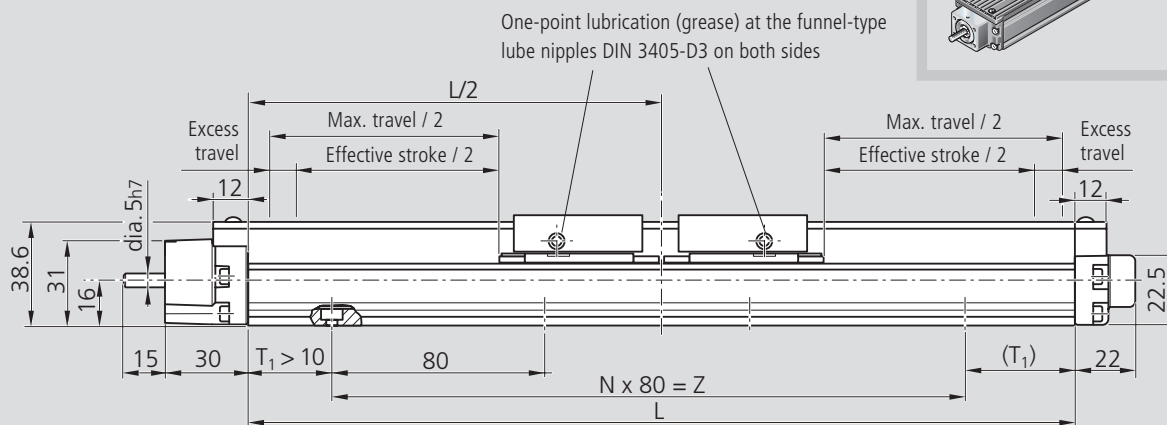
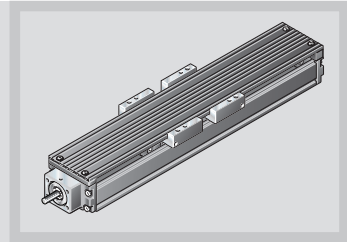

Version:
one or two carriages

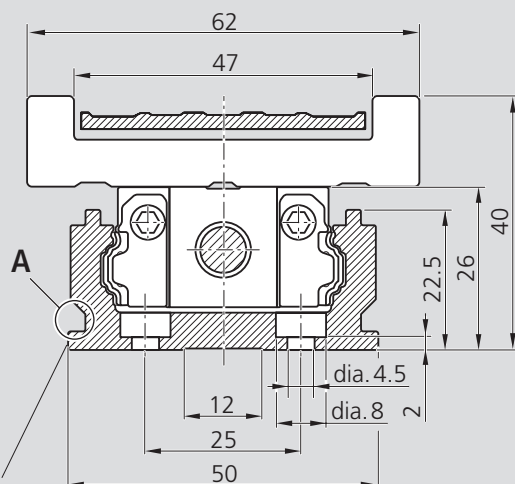
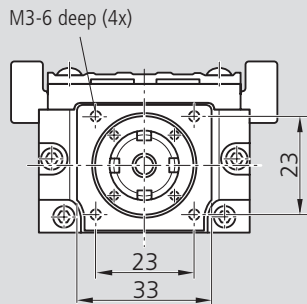
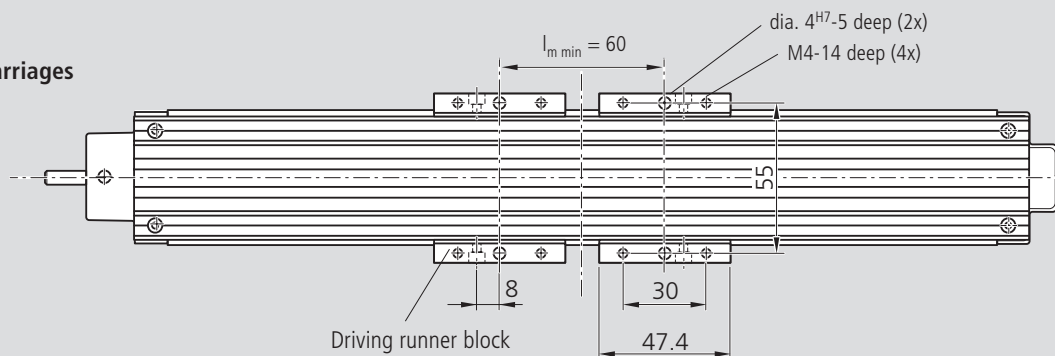

Reference edge

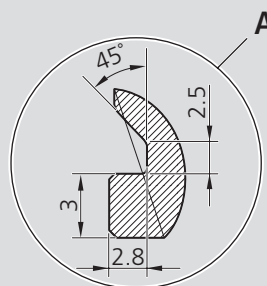

For mounting with clamping fixtures

Rexroth – Precision Module PSK 50

Dimension Drawings with Sealing Strip

All dimensions in mm

Diagrams to different scales

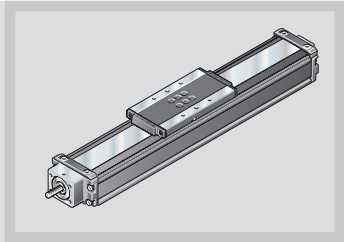

One-point lubrication (grease) at the funnel-type lube nipples DIN 3405-D3 on both sides

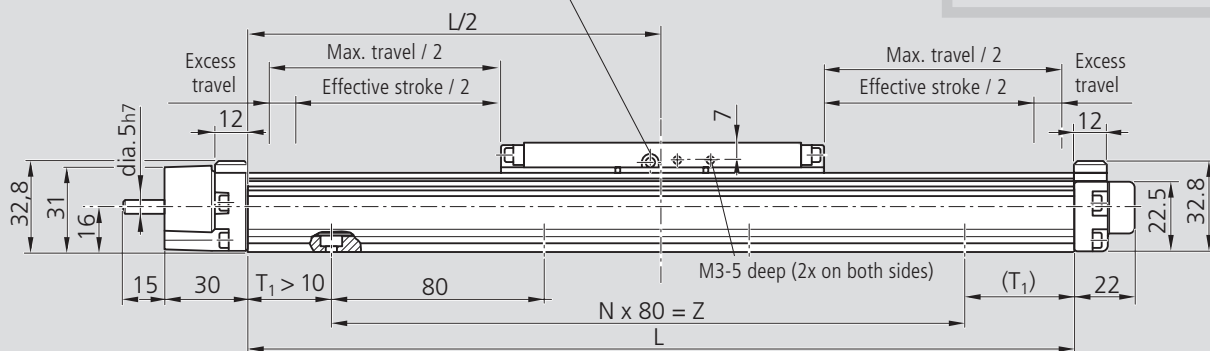

Version:
carriage, standard length

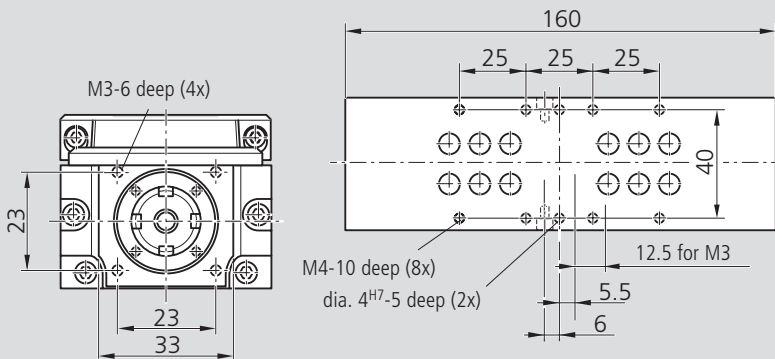
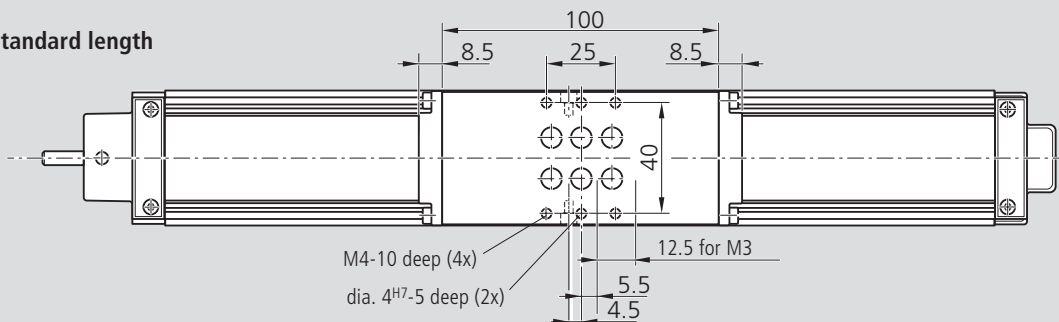

Version:
carriage, long

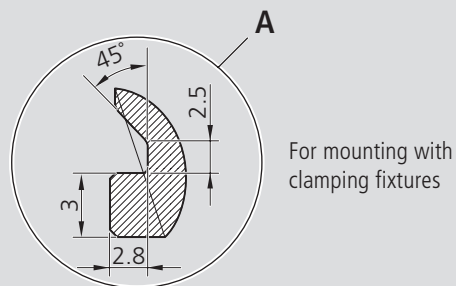
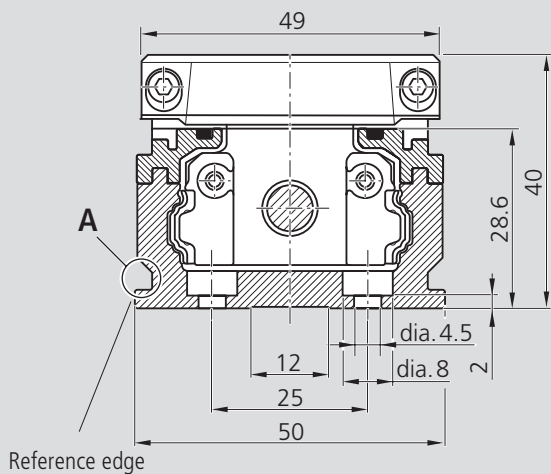

Rexroth – Precision Module PSK 50 Dimension Drawings

14.26.00

Type OF01 and OF02

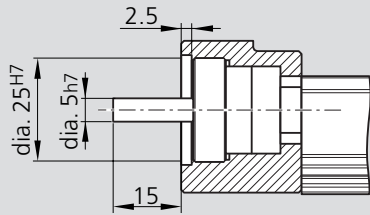

14.26.11

Type MF01 and MF02
Motor VRDM 368 with mount and coupling

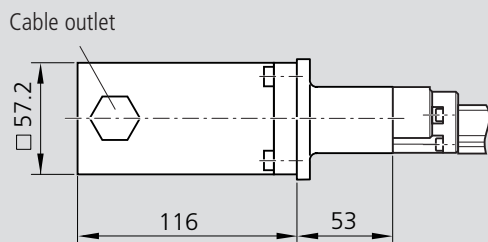

14.26.12

Type MF01 and MF02
Motor MSM 030B with mount and coupling

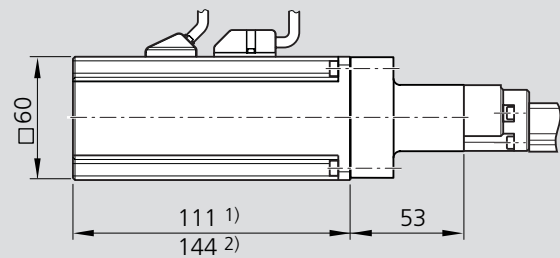

For further information and dimensions, see "Motors".

¹⁾ without brake

²⁾ with brake

14.26.16

Type MF10 and MF11
Integrated motor mount (NEMA 17 - type D)

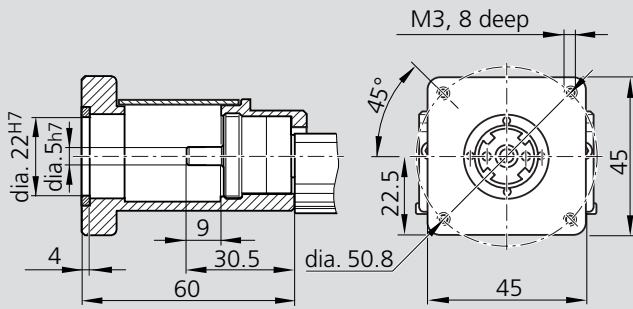

14.26.17

Type MF10 and MF11
Motor MSM 020B with integrated mount and coupling

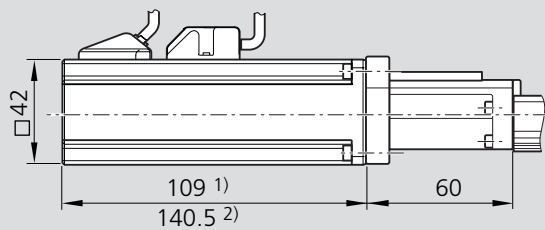

14.26.18



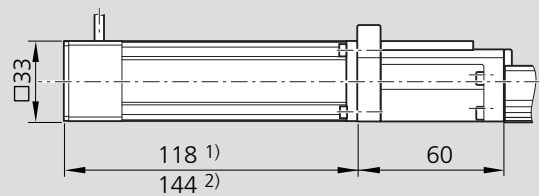

Type MF10 and MF11
Motor MSI 032 with integrated mount and coupling

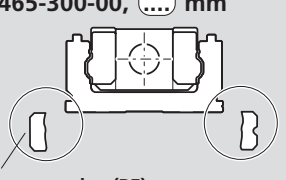

¹⁾ without brake ²⁾ with brake

Rexroth – Precision Module PSK 60

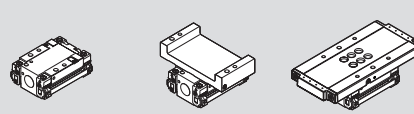
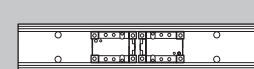
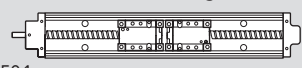
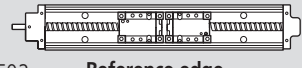
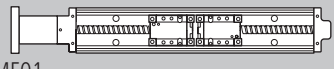
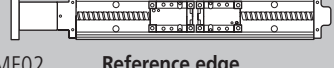
Components and Ordering Data

Part number, length 1465-300-00, ... mm 	... Type (and dimension drawing)	Guide- way = .. 	Drive unit = .. 	Carriage = .. 												
				Screw journal	Ball screw size d ₀ x P	For cover option	Steel		Aluminum							
Standard	Long	Standard	Long													
Reference edge (RE)				1 carr.* 2 carr.		1 carr. 2 carr.		1 carr. 2 carr.								
without drive (OA)  OA01	OA01	Length = L ① L = 150 mm ⑩ L = 200 mm ⑪ L = 250 mm ⑫ L = 300 mm ⑬ L = 400 mm ⑮ L = 500 mm ⑰ L = 600 mm ⑲ L = 700 mm ⑳	without screw journal	12 x 2 12 x 5 12 x 10 ⑤0	without cover	①	②	③	④	⑪	⑫	⑬	⑭			
with ball screw, without motor mount (OF) Reference edge  OF01  OF02 Reference edge	OF01 OF02 (14.36.00)		dia. 6	③	①	②	without cover	①	②	③	④	⑪	⑫	⑬	⑭	
						cover plate	⑲	⑳	㉑	㉒	㉓	㉔	㉕	㉖	㉗	
						sealing strip	--	--	--	--	④0	--	④1	--	--	
with ball screw and motor mount (MF) Reference edge  MF01  MF02 Reference edge	MF01 MF02 (14.36.11) (14.36.13)		dia. 6	③	①	②	without cover	①	②	③	④	⑪	⑫	⑬	⑭	
						cover plate	⑲	⑳	㉑	㉒	㉓	㉔	㉕	㉖	㉗	
						sealing strip	--	--	--	--	④0	--	④1	--	--	
with ball screw and integrated motor mount (MF) MF10 MF11 Reference edge  MF10  MF11 Reference edge	MF10 MF11 (14.36.16) (14.36.17) (14.36.18)		dia. 6	③0	③1	③2	without cover	①	②	③	④	⑪	⑫	⑬	⑭	
						cover plate	⑲	⑳	㉑	㉒	㉓	㉔	㉕	㉖	㉗	
						sealing strip	--	--	--	--	④0	--	④1	--	--	
with ball screw and timing belt side drive (RV) RE left RE right RV01 RV02 RV03 RV04 RV05 RE RV06 RE RV07 RE RV08 RE	RV01 RV02 RV03 RV04 RV05 RV06 RV07 RV08 (14.36.20)		RV01 to RV08	for MKD 25	⑤3	⑤1	⑤2	without cover	①	②	③	④	⑪	⑫	⑬	⑭
				for MSM 030B	⑤3	⑤1	⑤2	cover plate	⑲	⑳	㉑	㉒	㉓	㉔	㉕	㉖
						sealing strip	--	--	--	--	④0	--	④1	--	--	

For order example see "Inquiry/Order Form" section.

* carr. = carriage

Switch mounting arrangements

A cable duct is required to mount the switches.

For more information on switch mounting and switch types, see the section on "Switch Mounting Arrangements".

Please check whether the selected combination is a permissible one (load capacities, moments, maximum speed, motor data, etc.)!

Motor attachment = ..		Motor = ..		Cover = ..		1st, 2nd, 3rd switch = ..		Documentation = ..	
Gear ratio i =	Attachment kit ¹⁾	for motor	Motor type	with- out cover	with cover plate	with sealing strip	Cable duct Switching cam	Standard report	Measure- ment report
	00	--	00	00					
	00	--	00	00	01		without switch and cable duct 00	01	02 Friction moment
				00			Switch: Reed contact 21 - ... Hall sensor 22 - ...		03 Lead deviation
	02	VRDM 368	27	00			Switch type Mounting side		04 Running accuracy
	03	MSM 030B	71 70 ²⁾	00	01		Cable duct 25		05 Positioning accuracy
				00			Switching cam for: - without cover 30 - with cover plate		
	31	NEMA 23-D	00	00			Switching cam for sealing strip 31		
	32	MKD 25B	50	00	01				
	33	MSI 040	79 78 ²⁾	00		02			
	i=1 11	MKD 25B	50	00					
	i=1.5 12			00	01				
	i=1 13	MSM 030B	71 70 ²⁾	00					
	i=1.5 14			00		02			

1) Attachment kit can also be supplied without motor (enter "00" for motor on order form).
2) Motor without brake

Mounting side for switches:
Switches may be mounted on the left (L)
or right (R) side of the Precision Module.

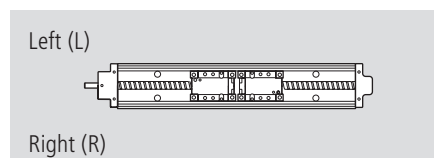

Rexroth – Precision Module PSK 60

Lengths and Hole Spacing

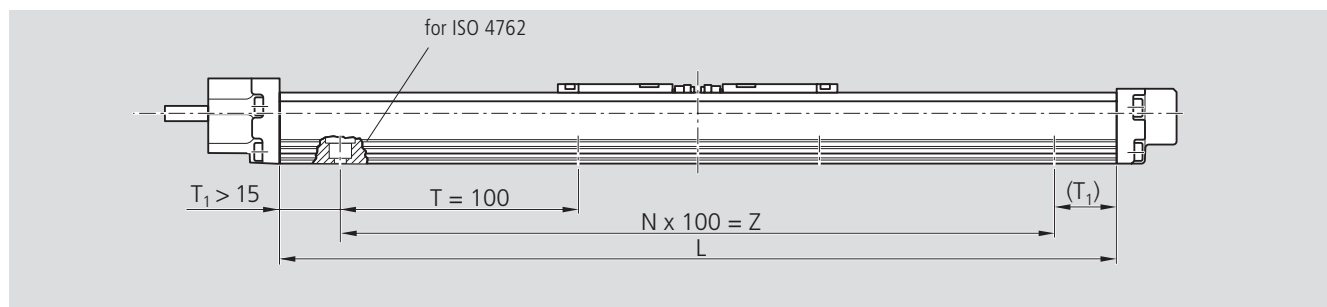

Length L

	Number of carriages	Carriage version	
		Standard length	Long
without cover and with cover plate	one carriage	$L = (\text{stroke} + 2 \cdot \text{excess travel}) + 70 \text{ mm}$	$L = (\text{stroke} + 2 \cdot \text{excess travel}) + 85 \text{ mm}$
	two carriages	$L = (\text{stroke} + 2 \cdot \text{excess travel}) + l_m + 70 \text{ mm}$ $l_{m \text{ min}} = 60 \text{ mm}$	$L = (\text{stroke} + 2 \cdot \text{excess travel}) + l_m + 85 \text{ mm}$ $l_{m \text{ min}} = 75 \text{ mm}$
with sealing strip	one carriage	$L = (\text{stroke} + 2 \cdot \text{excess travel}) + 160 \text{ mm}$	$L = (\text{stroke} + 2 \cdot \text{excess travel}) + 215 \text{ mm}$

l_m = center-to-center distance between carriages (observe $l_{m \text{ min}}$)
 Stroke = maximum travel of carriage center between the outermost switch activation points.

In most cases the recommended limit for excess travel (braking path) is:

Excess travel = $2 \cdot \text{screw lead } P$
 Example:
 Ball screw 12×10 ($d_0 \times P$),
 Excess travel = $2 \cdot 10 = 20 \text{ mm}$

Preferred lengths of frame

Length L	T_1	T	N	Z	for ISO 4762 screws
150	25	100	1	100	M5
200	50	100	1	100	
250	25	100	2	200	
300	50	100	2	200	
400	50	100	3	300	
500	50	100	4	400	
600	50	100	5	500	
700	50	100	6	600	

Variable length

Calculating the hole pattern for the frame

Applies to all cover options

Precision module length L (mm)
 Hole spacing T = 100 mm
 Minimum end space $T_{1 \text{ min}} = 15 \text{ mm}$

$$N_1 = \frac{L}{T} = \frac{L}{100}$$

$$N = \text{INT}(N_1) \text{ (whole number of } N_1)$$

$$T_1 = \frac{L - T \cdot N}{2} = \frac{L - 100 \cdot N}{2}$$

$T_1 > T_{1 \text{ min}} \rightarrow N, T_1$

$T_1 \leq T_{1 \text{ min}} \rightarrow N = N - 1$
 $T_1 = T_1 + 50 \text{ mm}$

Result:
 Hole pattern: $T_1 / N \cdot 100 / T_1$

Example:
 L = 430 mm

$$N_1 = \frac{L}{T} = \frac{430}{100} = 4.3$$

$$N = 4$$

$$T_1 = \frac{430 - 100 \cdot 4}{2} = 15$$

$T_1 \leq T_{1 \text{ min}} \rightarrow N = 4 - 1 = 3$
 $T_1 = 15 + 50 = 65$

65 mm / 3 · 100 mm / 65 mm

Rexroth – Precision Module PSK 60

Dimension Drawings without Cover

All dimensions in mm

Diagrams to different scales

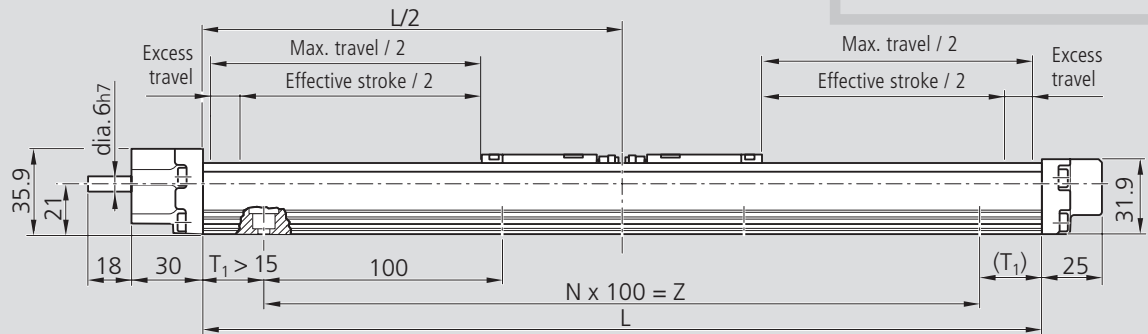
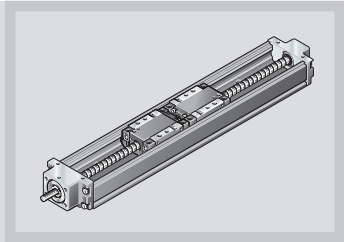

Version:
one or two carriages,
standard length

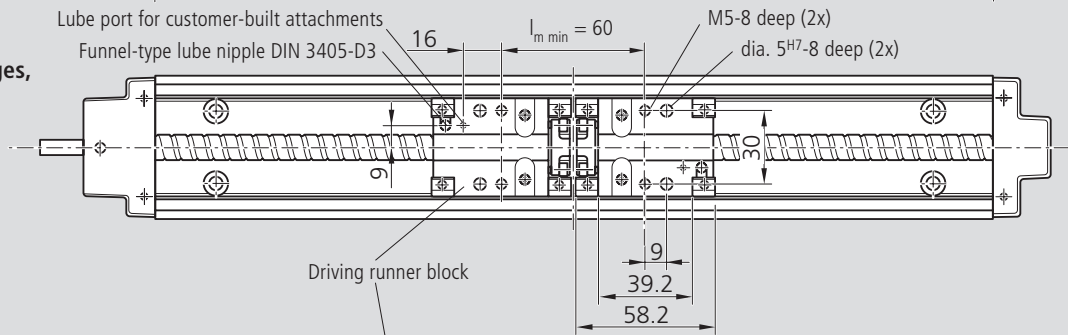

Version:
one or two carriages,
long

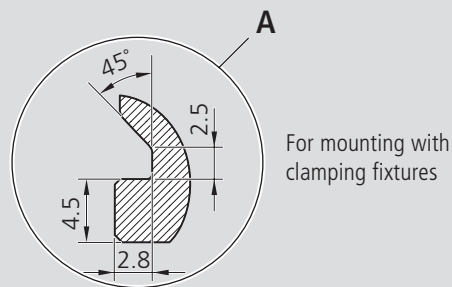
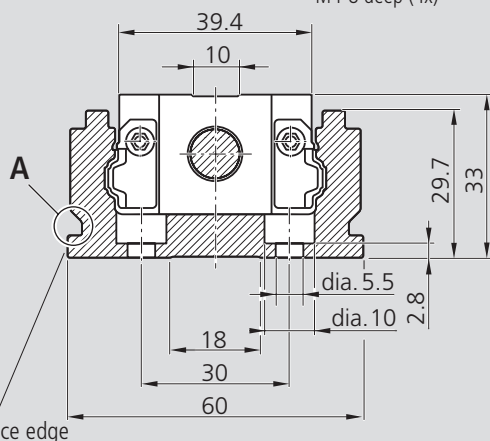
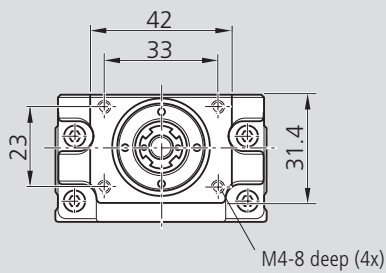
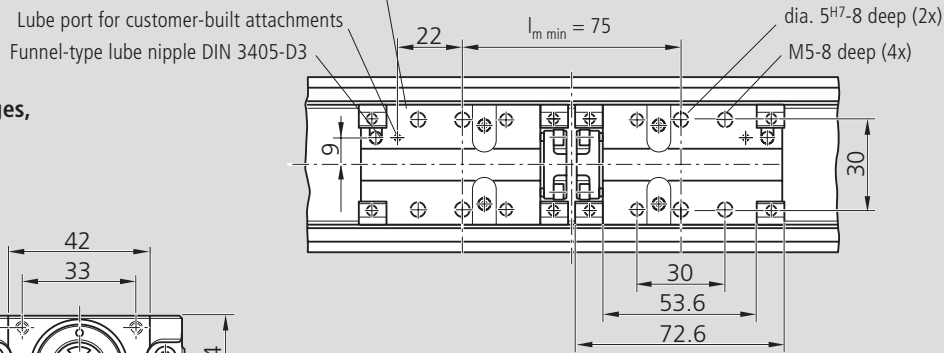

Reference edge

Rexroth – Precision Module PSK 60

Dimension Drawings with Sealing Strip

All dimensions in mm

Diagrams to different scales

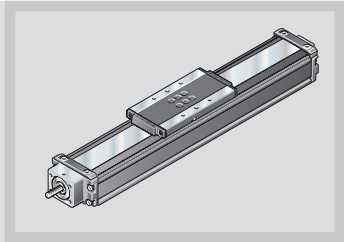

One-point lubrication (grease) at the funnel-type lube nipples DIN 3405-D3 on both sides

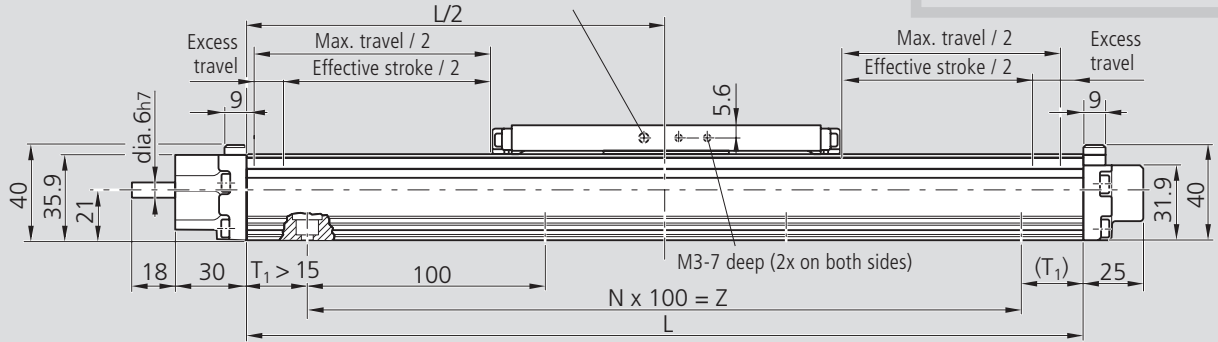

Version:
carriage, standard length

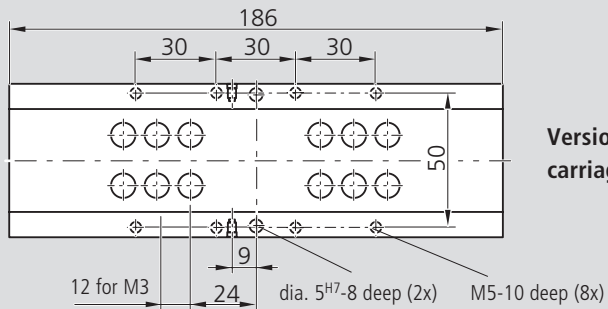
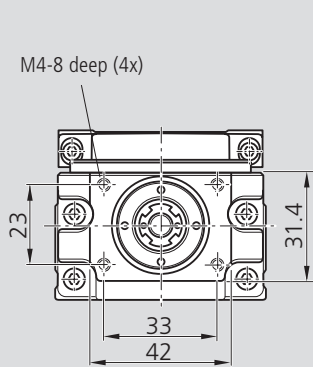
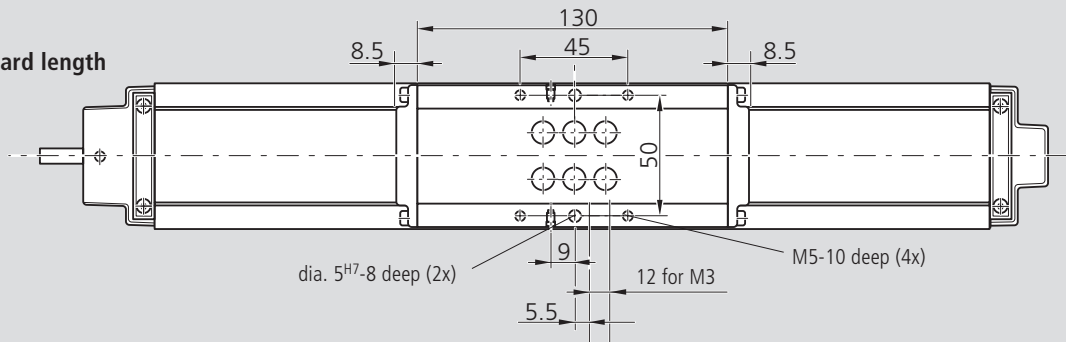

Version:
carriage, long

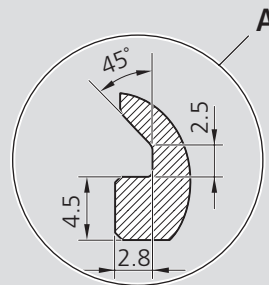
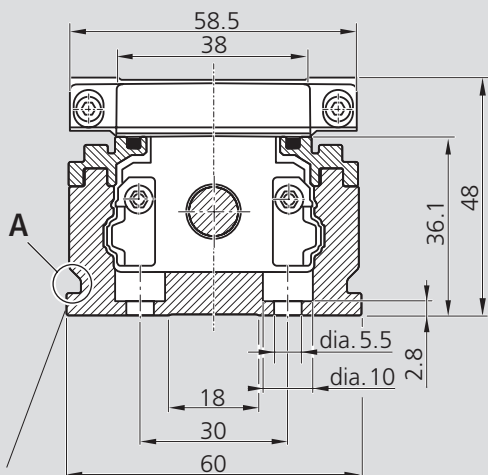

For mounting with clamping fixtures

Reference edge

Rexroth – Precision Module PSK 60

Dimension Drawings

14.36.00

Type OF01 and OF02

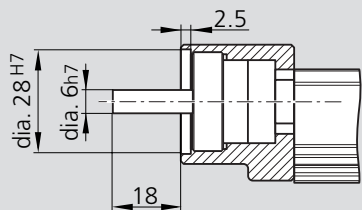

14.36.11

Type MF01 and MF02
Motor VRDM 368 with mount and coupling

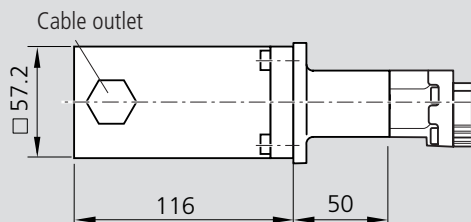

14.36.13

Type MF01 and MF02
Motor MSM 030B with mount and coupling

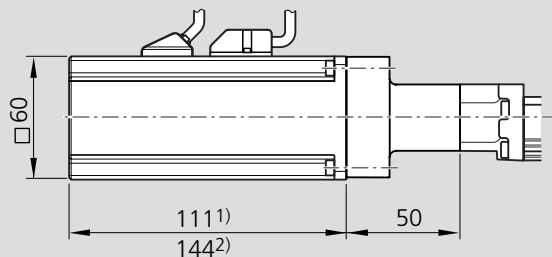

14.36.16

Type MF10 and MF11
Integrated motor mount (NEMA 23 - type D)
M4, 10 deep

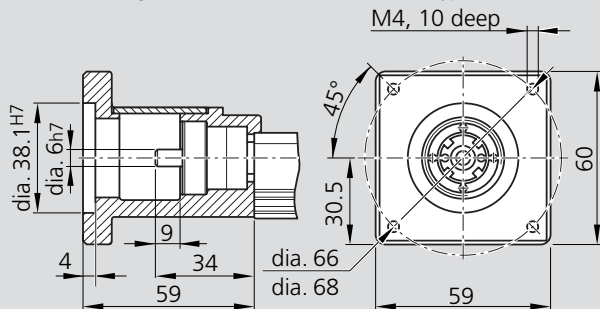

14.36.17

Type MF10 and MF11
Motor MKD with integrated mount and coupling

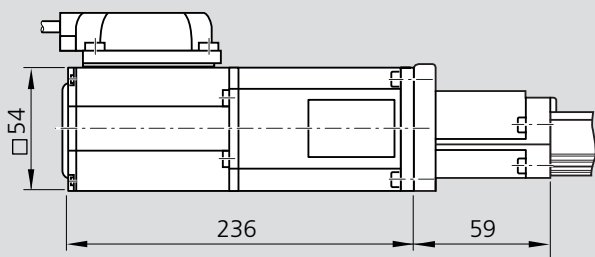

14.36.18

Type MF10 and MF11
Motor MSI 040 with integrated mount and coupling

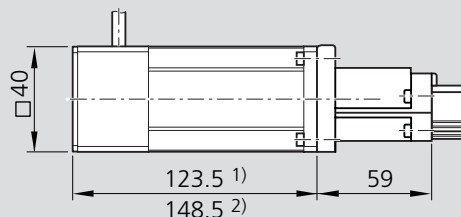

For further information and dimensions, see "Motors".

¹⁾ without brake

²⁾ with brake

14.36.20

Type RV01 to RV08



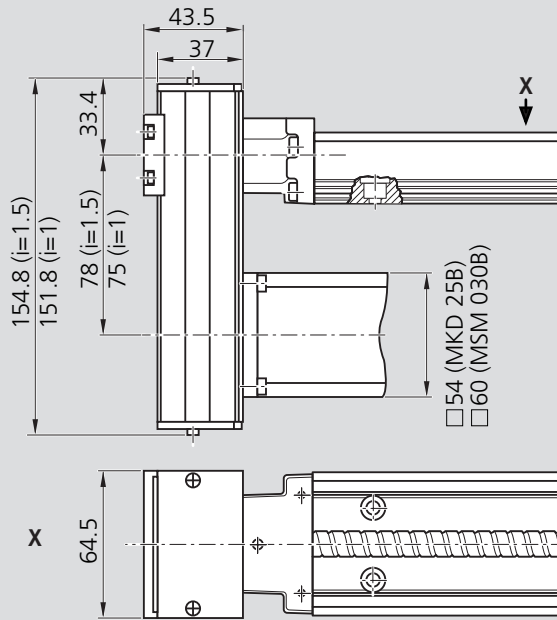







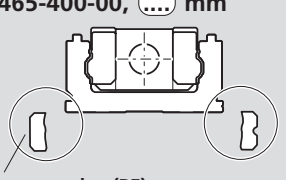

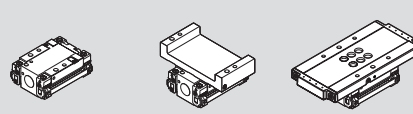
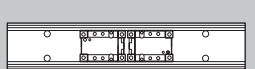
Motors MKD 25B and MSM 030B with side drive and timing belt

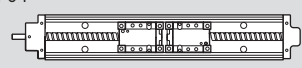
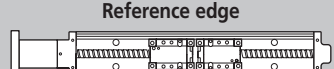

Motor not shown in drawing

Rexroth – Precision Module PSK 90

Components and Ordering Data

Part number, length 1465-400-00, ... mm 	... Type (and dimension drawing)	Guide- way = ... 	Drive unit = .. 	Carriage = .. 									
				Screw journal	Ball screw size $d_0 \times P$	For cover option	Steel		Aluminum				
							Standard 1 carr.* 2 carr.	Long 1 carr. 2 carr.	Standard 1 carr. 2 carr.	Long 1 carr. 2 carr.			
without drive (OA)  OA01	OA01	Length = L ① L = 340 mm ⑩ L = 440 mm ⑫ L = 540 mm ⑭ L = 640 mm ⑯ L = 740 mm ⑱ L = 840 mm ⑳ L = 940 mm ㉒	without screw journal	16 x 5 16 x 10 16 x 16	without cover	① ② ③ ④ ⑪ ⑫ ⑬ ⑭							
with ball screw, without motor mount (OF) Reference edge  OF01	OF01 OF02 (14.46.00)			dia. 9	① ② ③	with- out cover	① ② ③ ④ ⑪ ⑫ ⑬ ⑭						
 OF02	Reference edge			dia. 9 with keyway	⑪ ⑫ ⑬	cover plate	②① ②② ②③ ②④ ③① ③② ③③ ③④						
with ball screw and motor mount (MF) Reference edge  MF01	MF01 MF02 (14.46.11) (14.46.12)			dia. 9	① ② ③	sealing strip	-- -- -- -- ④① -- ④② --						
 MF02	Reference edge					with- out cover	① ② ③ ④ ⑪ ⑫ ⑬ ⑭						
with ball screw and integrated motor mount (MF) MF10 MF11 Reference edge  Reference edge 	MF10 MF11 (14.46.16) (14.46.17) (14.46.18)			dia. 9	③① ③② ③③	cover plate	②① ②② ②③ ②④ ③① ③② ③③ ③④						
with ball screw and timing belt side drive (RV) RE left RE right RV01 RV02  RV03 RV04  RV05 RE RV06 RE  RV07 RE RV08 RE 	RV01 to RV04 (14.46.20) RV05 to RV08 (14.46.21) RV01 to RV04 (14.46.30) RV05 to RV08 (14.46.31)			for MKD 25, MSM 030C	⑥① ⑥② ⑥③	with- out cover	① ② ③ ④ ⑪ ⑫ ⑬ ⑭						
				for MKD 25, MSM 030C	⑥① ⑥② ⑥③	cover plate	②① ②② ②③ ②④ ③① ③② ③③ ③④						
				for MKD 41, MSM 040B	⑤① ⑤② ⑤③	sealing strip	-- -- -- -- ④① -- ④② --						
				for MKD 41, MSM 040B	⑤① ⑤② ⑤③								

For order example see "Inquiry/Order Form" section.

* carr. = carriage

Switch mounting arrangements

A cable duct is required to mount the switches.

For more information on switch mounting and switch types, see the section on "Switch Mounting Arrangements".

Please check whether the selected combination is a permissible one (load capacities, moments, maximum speed, motor data, etc.)!

Motor attachment = ..		Motor = ..		Cover = ..			1st, 2nd, 3rd switch = ..	Documentation = ..	
Gear ratio i =	Attachment kit ¹⁾	for motor	Motor type	with- out cover	with cover plate	with sealing strip	Cable duct Switching cam	Standard report	Measure- ment report
	00	--	00	00					
	00	--	00	00	01		without switch and cable duct 00	01	02 Friction moment
				00		02	Switch: Reed contact 21 - ... Hall sensor 22 - ...		03 Lead deviation
				00			Switch type Mounting side		04 Running accuracy
				00	01		Cable duct 25		
	03	MKD 41B	10	00			Switching cam for: - without cover 30 - with cover plate	05 Positioning accuracy	
	04	VRDM 397 VRDM 3910	28 29	00	01		Switching cam for sealing strip 31		
	06	MSM 40B	75 74 ²⁾	00		02			
	31	NEMA 23-D	00	00					
	32	MKD 25B	50	00	01				
	33	MSM 030C	73 72 ²⁾	00					
	34	MSI 055	81 80 ²⁾	00		02			
	i = 1.0 20	MKD 25B	50						
	i = 1.5 22								
	i = 1.0 21	MSM 030C	73 72 ²⁾	00					
	i = 1.5 23								
	i = 1.0 24	MKD 25B	50						
	i = 1.5 26								
	i = 1.0 25	MSM 030C	73 72 ²⁾						
	i = 1.5 27								
	i = 1.0 10	MKD 41B	10	00	01				
	i = 1.5 12								
	i = 1.0 11	MSM 040B	75 74 ²⁾						
	i = 1.5 13								
	i = 1.0 14	MKD 41B	10	00		02			
	i = 1.5 16								
	i = 1.0 15	MSM 040B	75 74 ²⁾						
	i = 1.5 17								

1) Attachment kit can also be supplied without motor (enter "00" for motor on order form).
2) Motor without brake

Mounting side for switches:
Switches may be mounted on the left (L)
or right (R) side of the Precision Module.

Left (L)

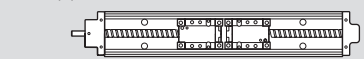

Right (R)

Rexroth – Precision Module PSK 90

Lengths and Hole Spacing

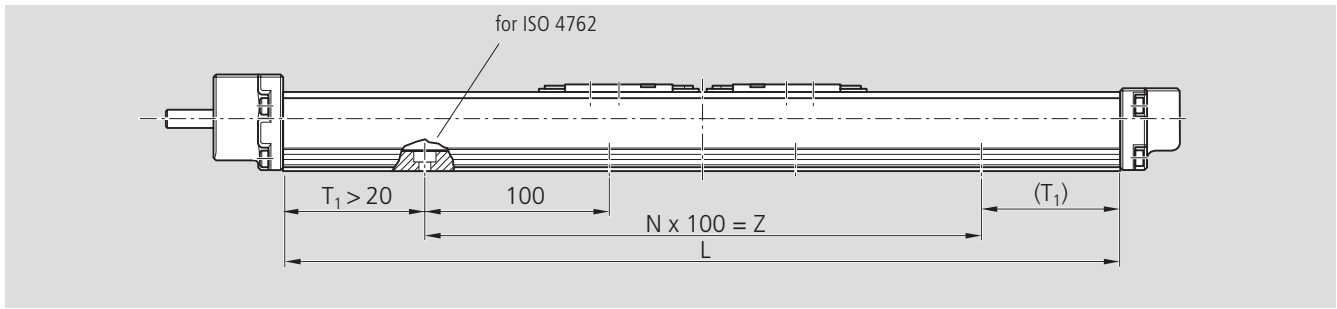

Length L

	Number of carriages	Carriage version	
		Standard length	Long
without cover and with cover plate	one carriage	$L = (\text{stroke} + 2 \cdot \text{excess travel}) + 100 \text{ mm}$	$L = (\text{stroke} + 2 \cdot \text{excess travel}) + 120 \text{ mm}$
	two carriages	$L = (\text{stroke} + 2 \cdot \text{excess travel}) + l_m + 100 \text{ mm}$ $l_{m \text{ min}} = 90 \text{ mm}$	$L = (\text{stroke} + 2 \cdot \text{excess travel}) + l_m + 120 \text{ mm}$ $l_{m \text{ min}} = 110 \text{ mm}$
with sealing strip	one carriage	$L = (\text{stroke} + 2 \cdot \text{excess travel}) + 190 \text{ mm}$	$L = (\text{stroke} + 2 \cdot \text{excess travel}) + 265 \text{ mm}$

l_m = center-to-center distance between carriages (observe $l_{m \text{ min}}$)
 Stroke = maximum travel of carriage center between the outermost switch activation points.

In most cases the recommended limit for excess travel (braking path) is:

Excess travel = $2 \cdot \text{screw lead } P$
 Example:
 Ball screw 16×10 ($d_0 \times P$),
 Excess travel = $2 \cdot 10 = 20 \text{ mm}$

Preferred lengths of frame

Length L	T_1	T	N	Z	for ISO 4762 screws
340	70	100	2	200	M6
440	70	100	3	300	
540	70	100	4	400	
640	70	100	5	500	
740	70	100	6	600	
840	70	100	7	700	
940	70	100	8	800	

Variable length

Calculating the hole pattern for the frame

Applies to all cover options

Precision module length L (mm)
 Hole spacing T = 100 mm
 Minimum end space $T_{1 \text{ min}} = 20 \text{ mm}$

$$N_1 = \frac{L}{T} = \frac{L}{100}$$

$N = \text{INT}(N_1)$ (whole number of N_1)

$$T_1 = \frac{L - T \cdot N}{2} = \frac{L - 100 \cdot N}{2}$$

$$T_1 > T_{1 \text{ min}} \rightarrow N, T_1$$

$$T_1 \leq T_{1 \text{ min}} \rightarrow N = N - 1$$

$$T_1 = T_1 + 50 \text{ mm}$$

Result:
 Hole pattern: $T_1 / N \cdot 100 / T_1$

Example:

$L = 440 \text{ mm}$

$$N_1 = \frac{L}{T} = \frac{440}{100} = 4.4$$

$N = 4$

$$T_1 = \frac{440 - 100 \cdot 4}{2} = 20$$

$$T_1 \leq T_{1 \text{ min}} \rightarrow N = 4 - 1 = 3$$

$$T_1 = 20 + 50 = 70$$

70 mm / 3 · 100 mm / 70 mm

Rexroth – Precision Module PSK 90

Dimension Drawings without Cover

All dimensions in mm

Diagrams to different scales

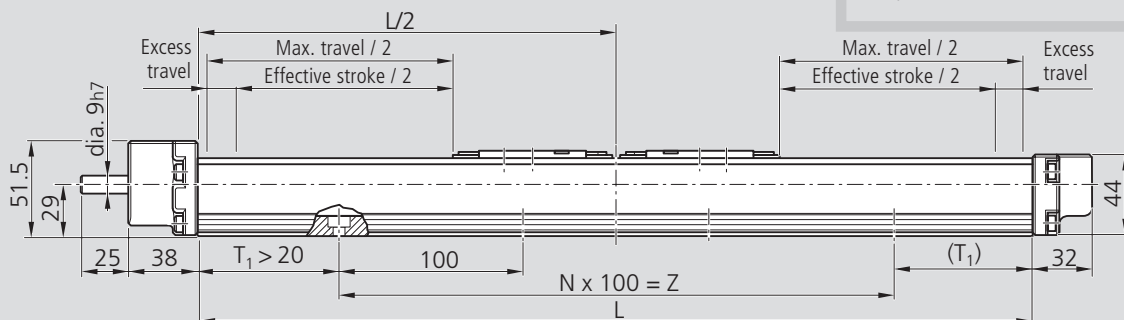
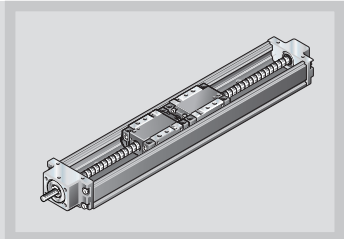

Version:
one or two carriages,
standard length

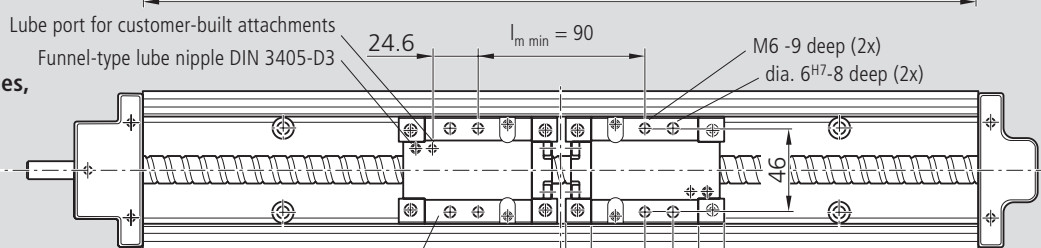

Version:
one or two carriages,
long

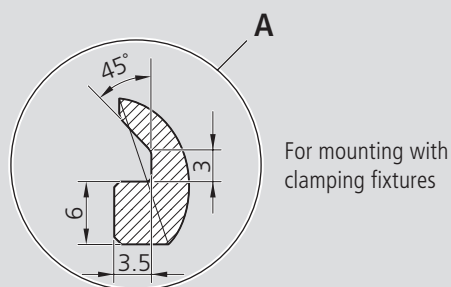
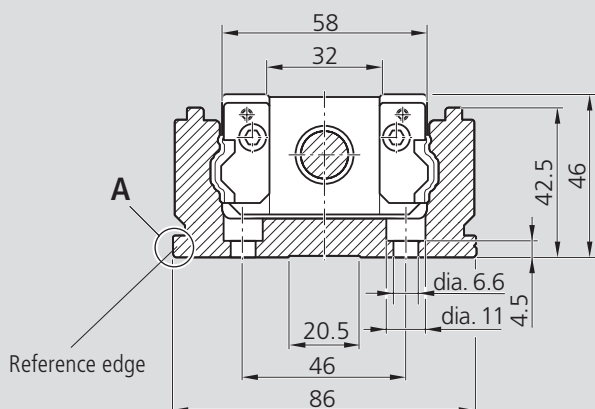
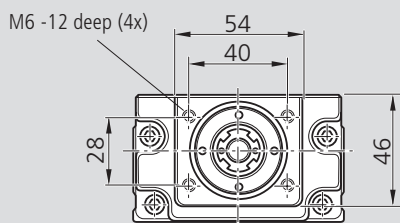
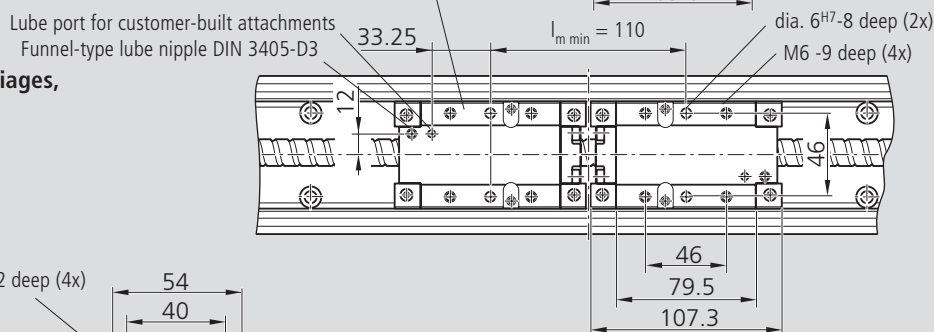

For mounting with clamping fixtures

Rexroth – Precision Module PSK 90

Dimension Drawings with Cover Plate

All dimensions in mm

Diagrams to different scales

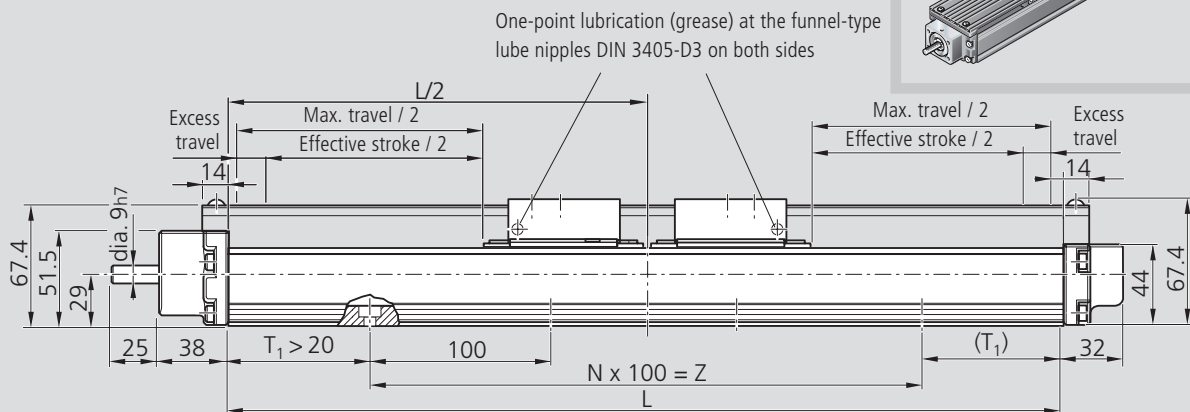
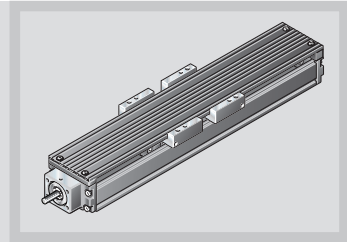

Version:
one or two carriages,
standard length

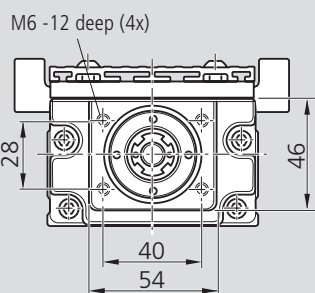
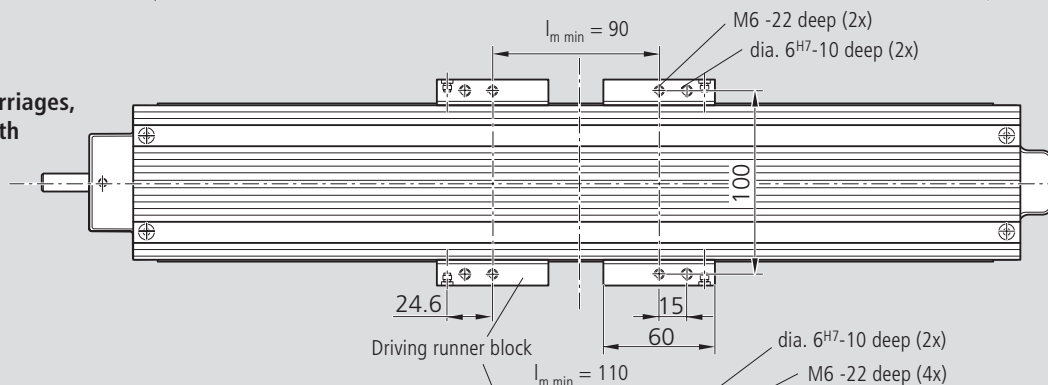

Version:
one or two carriages,
long

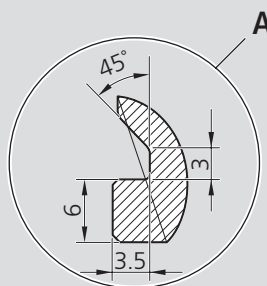
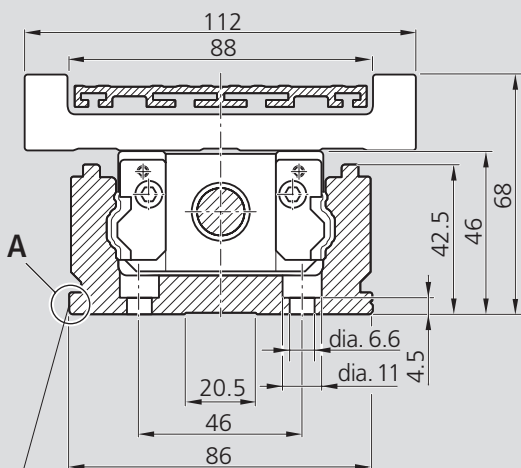
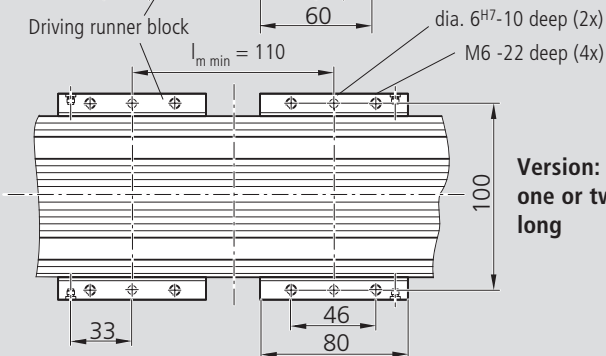

For mounting with
clamping fixtures

Rexroth – Precision Module PSK 90

Dimension Drawings with Sealing Strip

All dimensions in mm

Diagrams to different scales

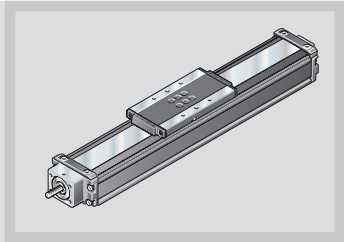

One-point lubrication (grease) at the funnel-type lube nipples DIN 3405-D3 on both sides

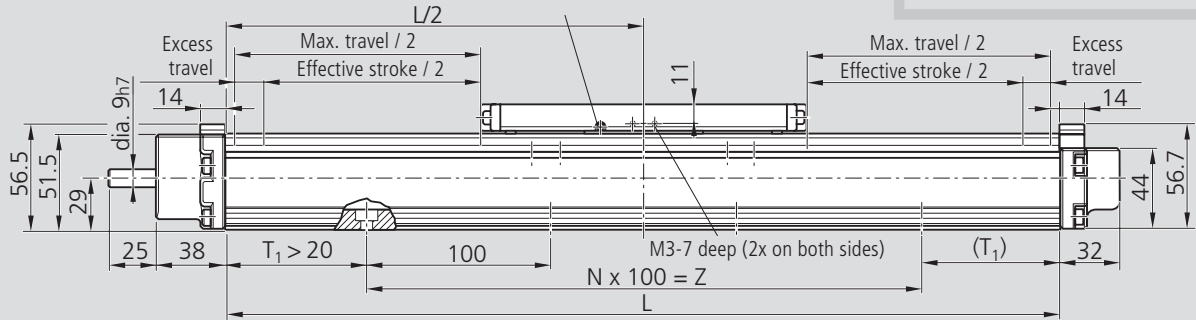

Version:
carriage, standard length

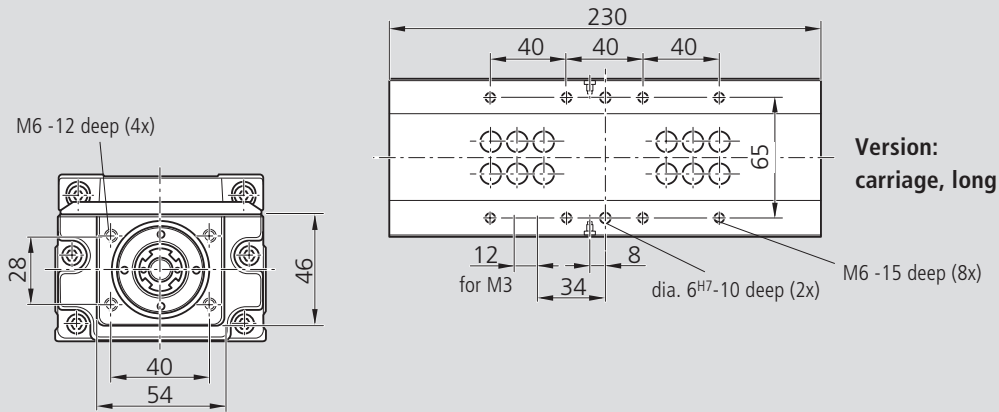
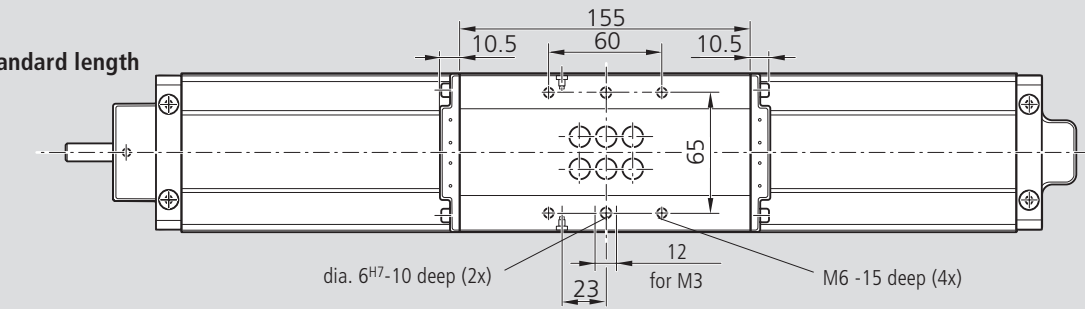

Version:
carriage, long

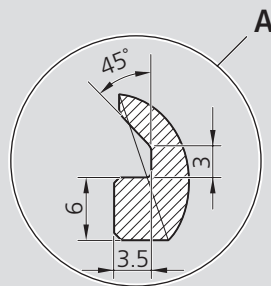
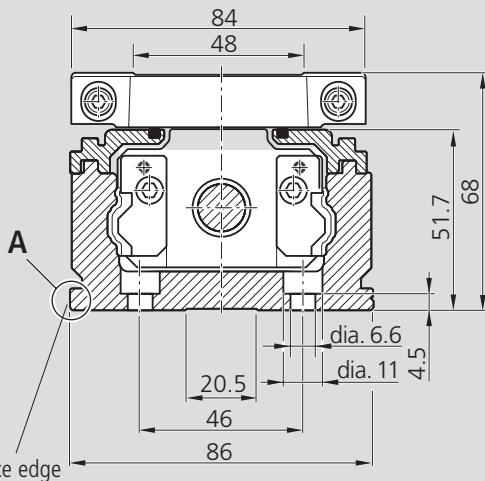

For mounting with clamping fixtures

Rexroth – Precision Module PSK 90

Dimension Drawings

14.46.00

Type OF01 and OF02

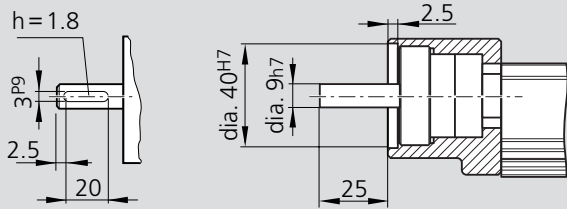

14.46.11

Type MF01 and MF02
Motor VRDM 39... with mount and coupling

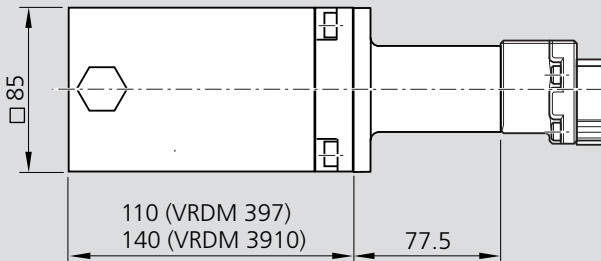

14.46.12

Type MF01 and MF02
Motor MKD 41B and MSM 040B with mount and coupling

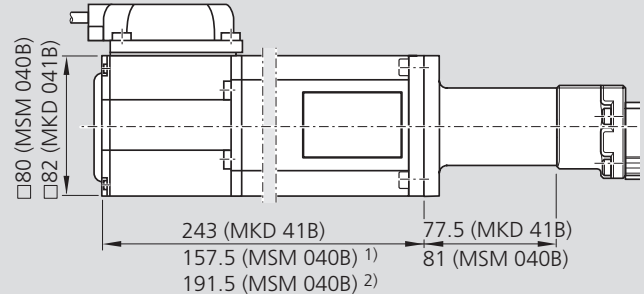

14.46.16

Type MF10 and MF11
Integrated motor mount (NEMA 23 - type D)

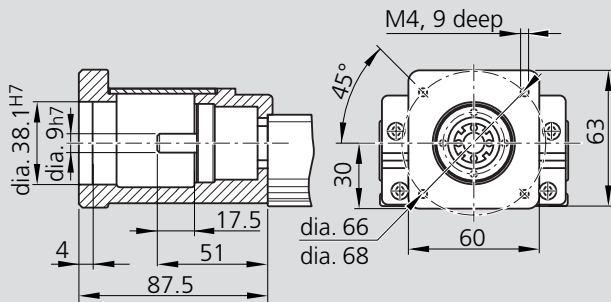

14.46.17

Type MF10 and MF11
Motors MKD 25B and MSM 030C with integrated mount and coupling

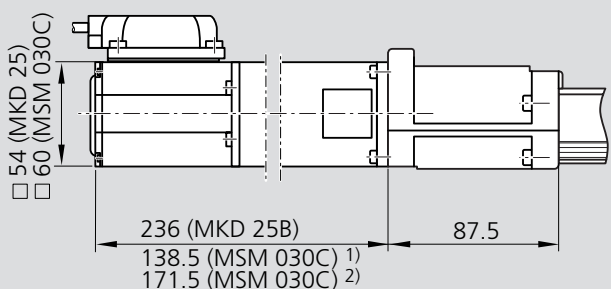

14.46.18

Type MF01 and MF02
Motor MSI 055 with integrated mount and coupling

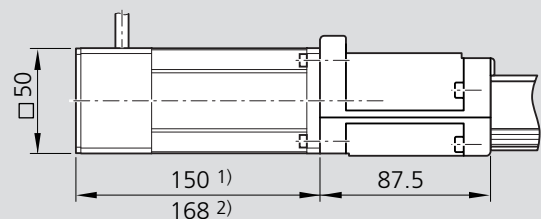

For further information and dimensions, see "Motors".

¹⁾ without brake

²⁾ with brake

14.46.20

Type RV01 and RV04
Motors MKD 25B and MSM 030C with side drive and timing belt

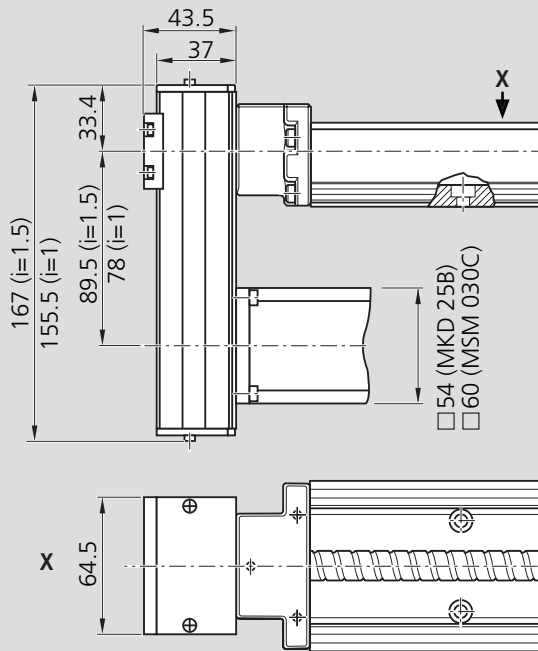

Motor not shown in drawing

14.46.21

Type RV05 and RV08
Motors MKD 25B and MSM 030C with side drive and timing belt

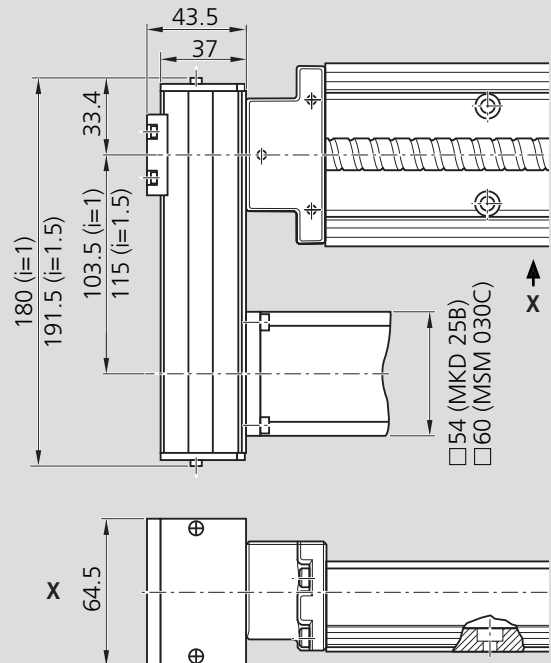

Motor not shown in drawing

14.46.30

Type RV01 and RV04
Motors MKD 41B and MSM 040B with side drive and timing belt

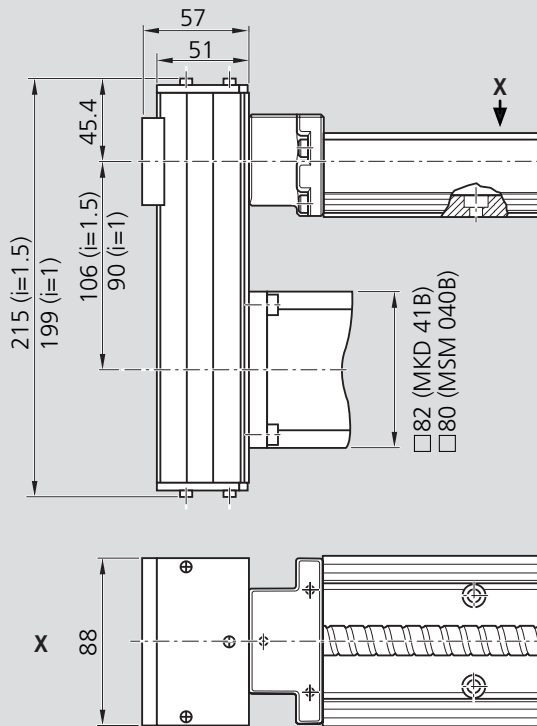

Motor not shown in drawing

14.46.31

Type RV05 and RV08
Motors MKD 41B and MSM 040C with side drive and timing belt

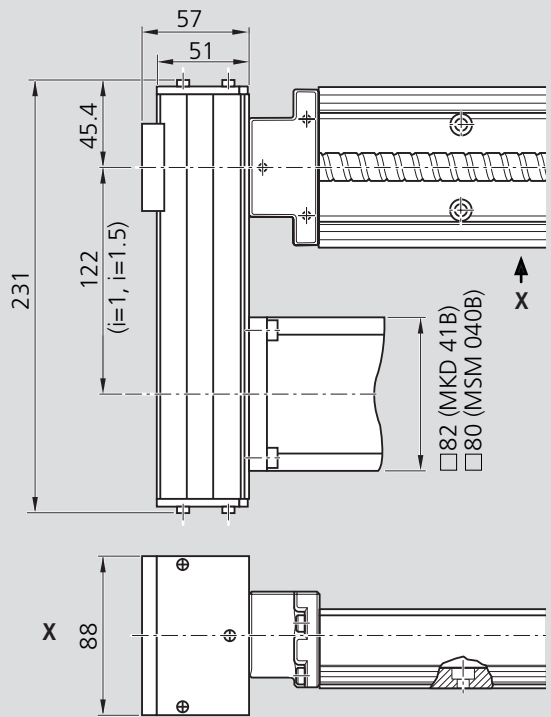

Motor not shown in drawing

Rexroth – Precision Modules PSK

Switch Mounting Arrangements

Overview of the switching system

- 1 Switch
- 2 Cable duct
(aluminum alloy, black anodized)
- 3 Switching cam

⚠ Short stroke: take the length of switch into consideration!

For two-carriages versions:
switch actuation by the driving runner block on the motor side.

Mounting side for switches:

Switches may be mounted on the left (L) or right (R) side of the module.

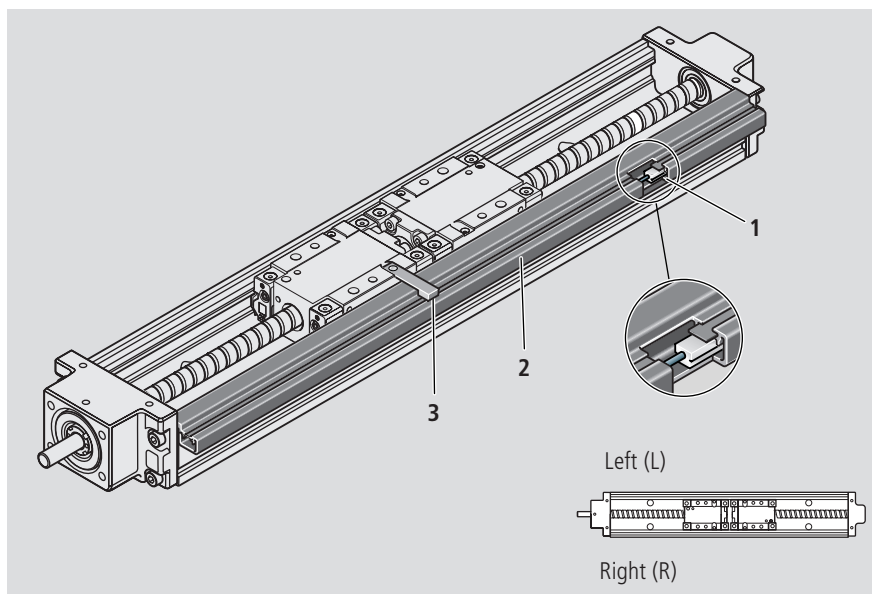

Switches

Miniature switches with potted cable.

Type:

- Hall sensor PNP NC or
- Reed contact (changeover)

On request:

- Hall sensor PNP NO
- Hall sensor NPN NC
- Hall sensor NPN NO

Mounting instructions:

Switches may only be mounted on one side (left or right) of the Precision Module.

A cable duct is required to mount the switches. Insert the switches into the T-slot in the cable duct and fix them in place using set screws.

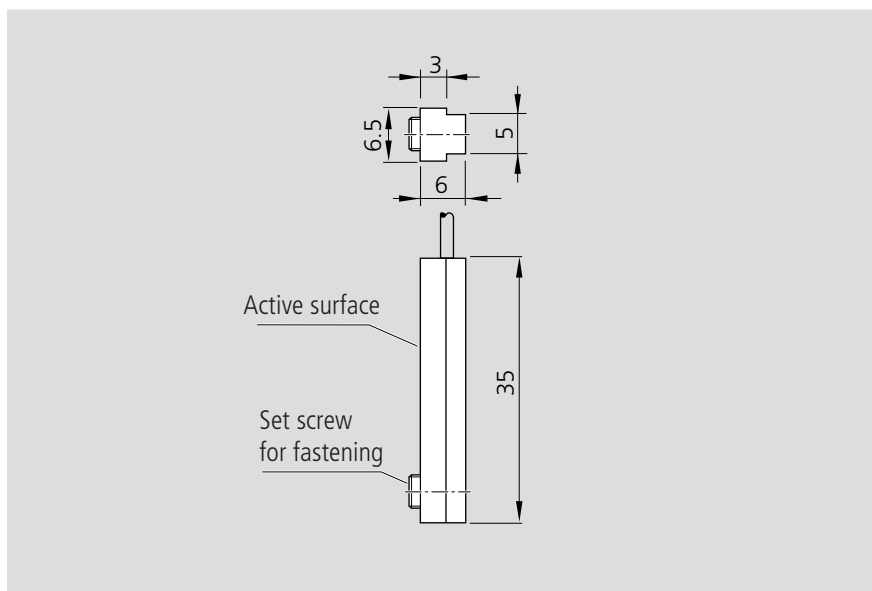

Hall sensor	
Type of contact	PNP NC
Service voltage	3.8 – 30 V DC
Power consumption	max. 10 mA
Output current	max. 20 mA
Cable length	2000 mm
Housing protection	IP 66
Short-circuit protection	No

Reed contact	
Type of contact	changeover
Switching voltage	max. 100 V DC
Switching current	max. 0.5 A
Cable length	2000 mm
Housing protection	IP 66

Pin allocation

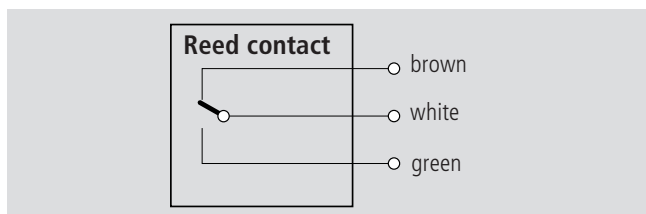
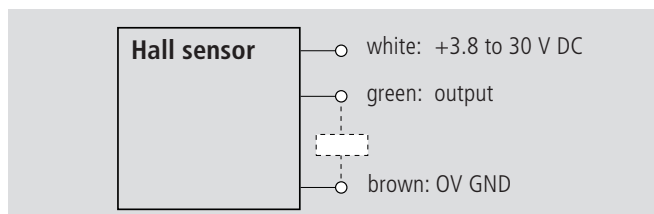

Rexroth – Precision Modules PSK Switch Mounting Arrangements

Cable duct

Function:

- to accommodate and secure switches
- to house cables

Mounting instructions:

Snap the cable duct into the T-slots on the frame and fix it in place using set screws (supplied along with the duct).

	PSK 50 (mm)	PSK 60 (mm)	PSK 90 (mm)
A	21.7	25.2	25.2
B	15.0	15.0	15.0
C	11.5	11.5	11.5
D	16.5	16.5	16.5
M	M2	M2.5	M2.5

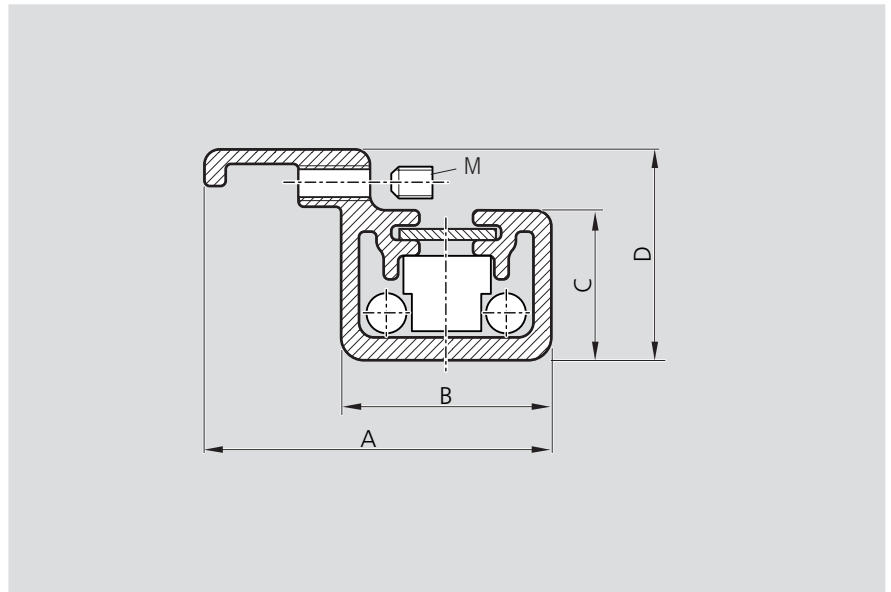

Installation dimensions for versions without cover and with cover plate

	PSK 50 (mm)	PSK 60 (mm)	PSK 90 (mm)
E	15.2	18.5	15.4
F	25.8	33.0	45.8
G	18.6	21.6	21.6
H	6.0	6.0	6.0

Install. dim. for version with sealing strip

	PSK 50 (mm)	PSK 60 (mm)	PSK 90 (mm)
E	15.2	15.8	15.2
F	28.1	35.7	50.2
G	11.2	12.0	12.0
H	12.5	14.0	14.0
I	4.3	1.9	7.1

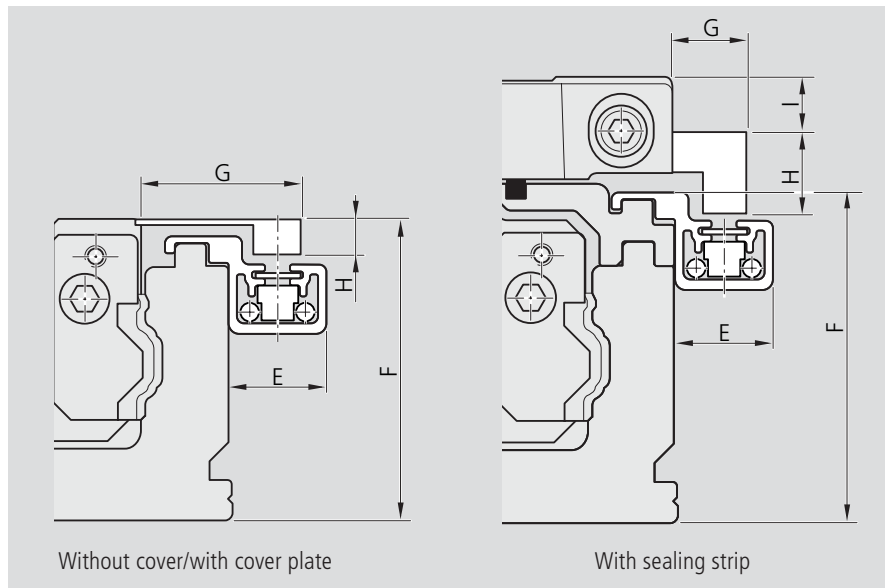

Ordering data for switches and mounting components

The part numbers are listed in the table below.

Mounting components can also be ordered individually.

Item		Part numbers		
		PSK 50	PSK 60	PSK 90
1	Switch			
	– Reed contact	8616-018-03		8616-018-03
	– Hall sensor	8616-019-03		8616-019-03
2	Cable duct	0396-620-20		0396-620-19
3	Switching cam			
	– for without cover and with cover plate	1419-000-10		1419-000-04
	– for sealing strip	1419-000-11		1419-000-05

Rexroth – Precision Modules PSK Motors

MKD servomotors

Dimensions and part numbers

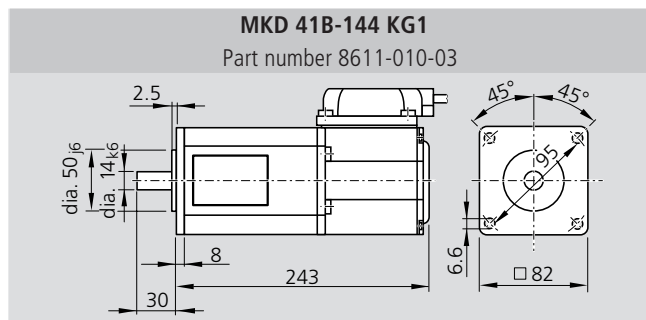
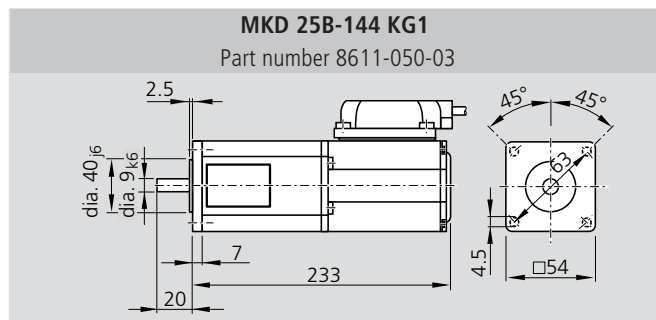

Motor data

Motor	MKD 25B	MKD 41B
Maximum effective speed n_{max} (min ⁻¹)	⚡	⚡
Rated torque M_N (Nm)	0.9	2.7
Maximum torque M_{max} (Nm)	⚡	⚡
Mass moment of inertia $J_M + J_{Br}$ (10 ⁻⁶ kgm ²)	30 + 8	170 + 16
Braking torque M_{Br} (Nm)	1.0	2.2
Mass with brake m_{Br} (kg)	2.25	4.65

⚡ See "Controllers – Servomotors" and "Controllers – Stepping Motors" catalogs.

VRDM three-phase stepping motors

Dimensions and part numbers

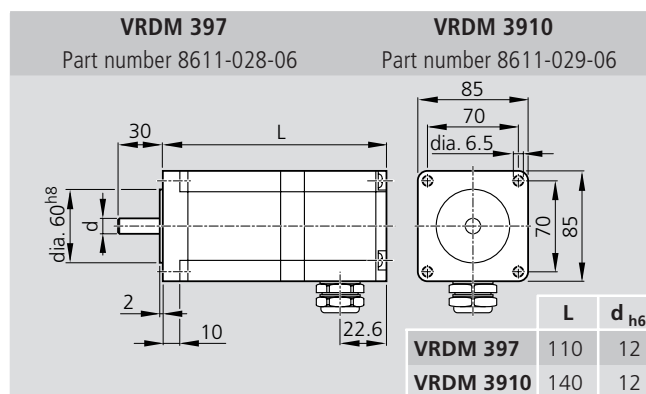
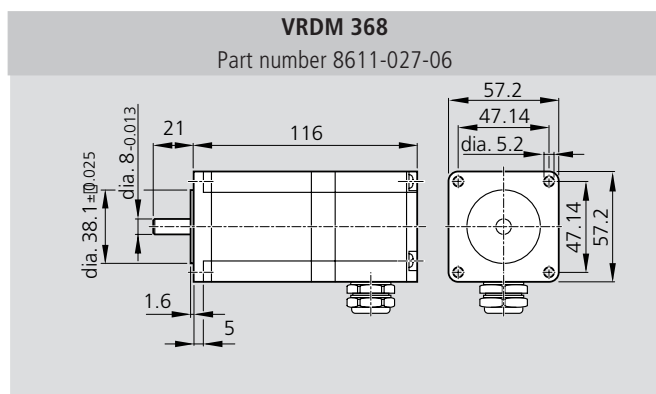

Motor data

Motor	VRDM 368 50 LWB	VRDM 397 50 LWB	VRDM 3910 50 LWB
Number of steps	200 / 400 / 500 / 1000		
Stepping angle (°)	1.8 / 0.9 / 0.72 / 0.36		
Maximum torque (Nm)	1.5	2.0	4.0
Mass moment of inertia (kgcm ²)	0.38	1.1	2.2
Braking torque (Nm)	1.74	2.26	4.52
Mass (kg)	1.1	2.05	3.1

Notes

The motors are available complete with controllers and control systems. More detailed information about motors, controllers and control systems can be found in the catalogs "Controllers – Servomotors" and "Controllers – Stepping Motors".

Rexroth – Precision Modules PSK Motors

MSM Servomotors

Dimensions, motor data and part numbers

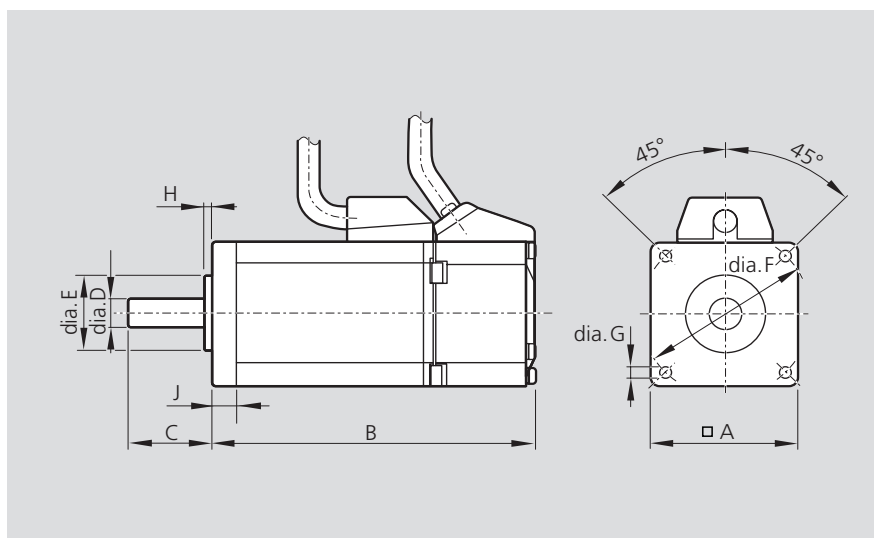

Dimensions of MSM servomotors

Values in parentheses apply to motor with holding brake

		MSM 020B	MSM 030B	MSM 030C	MSM 040B
A	[mm]	42	60	60	80
B	[mm]	109.0 (140.5)	111.0 (144.0)	138.5 (171.5)	157.5 (191.5)
C	[mm]	24	30	30	35
D _{h6}	[mm]	8	11	14	19
E _{h7}	[mm]	22	50	50	70
F	[mm]	48	70	70	90
G	[mm]	3.4	4.5	4.5	6.0
H	[mm]	2	3	3	3
J	[mm]	7	7	7	8

MSM servomotor data

Values in parentheses apply to motor with holding brake

n_{max}	Maximum effective speed
M_N	Rated torque
M_{max}	Maximum torque
J_M	Mass moment of inertia, motor
J_{Br}	Mass moment of inertia, brake
M_{Br}	Braking torque
m	Motor mass

		MSM 020B	MSM 030B	MSM 030C	MSM 040B
n_{max}	[min ⁻¹]	3 000	3 000	3 000	3 000
M_N	[Nm]	0.32	0.64	1.30	2.40
M_{max}	[Nm]	0.95	1.91	3.80	7.10
$J_M + J_{Br}$	[10 ⁻⁶ kgm ²]	3.2 + 0.4	10.0 + 3.0	17.0 + 3.0	67.0 + 8.0
M_{Br}	[Nm]	0.29	1.27	1.27	2.45
m	[kg]	0.5 (0.7)	0.96 (1.36)	1.5 (1.9)	3.1 (3.8)

Motor types and part numbers MSM servomotors

Motor type		Part number
MSM 020B-0300-NN-M0-CG0	without holding brake	8611-068-03
MSM 020B-0300-NN-M0-CG1	with holding brake	8611-069-03
MSM 030B-0300-NN-M0-CG0	without holding brake	8611-070-03
MSM 030B-0300-NN-M0-CG1	with holding brake	8611-071-03
MSM 030C-0300-NN-M0-CG0	without holding brake	8611-072-03
MSM 030C-0300-NN-M0-CG1	with holding brake	8611-073-03
MSM 040B-0300-NN-M0-CG0	without holding brake	8611-074-03
MSM 040B-0300-NN-M0-CG1	with holding brake	8611-075-03

All motors with absolute rotary encoder

Rexroth – Precision Modules PSK Motors

MSI Servomotors

Dimensions, motor data and part numbers

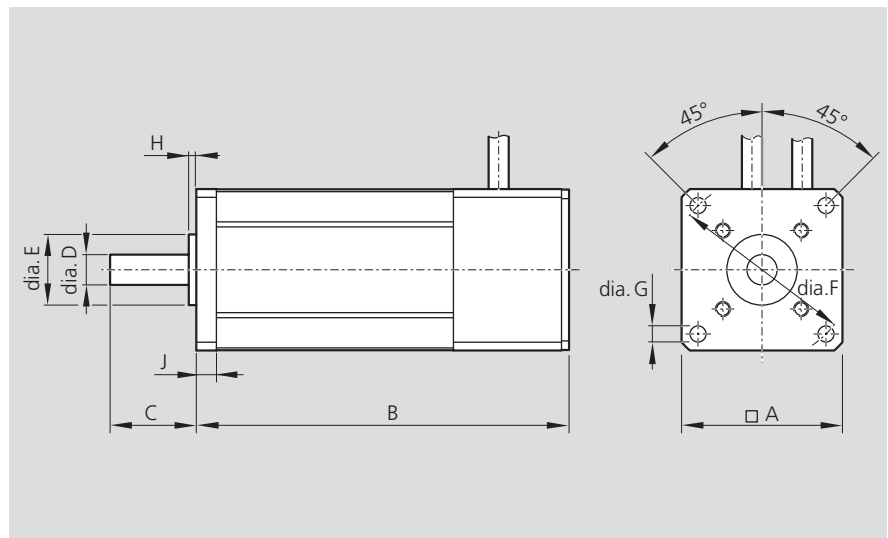

Dimensions of MSI servomotors

Values in parentheses apply to motor with holding brake

		MSI 032	MSI 040	MSI 055
A	[mm]	32	40	55
B	[mm]	118 (144.1)	123.5 (148.5)	150 (168)
C	[mm]	20	20	25
D	[mm]	6	6	9
E	[mm]	14	18	40
F	[mm]	36	48	65
G	[mm]	3.2	3.2	5.5
H	[mm]	1.5	2.5	2.5
J	[mm]	4	4	9

MSI servomotor data

Values in parentheses apply to motor with holding brake

n_{max}	Maximum effective speed
M_N	Rated torque
M_{max}	Maximum torque
J_M	Mass moment of inertia, motor
J_{Br}	Mass moment of inertia, brake
M_{Br}	Braking torque
m	Motor mass

		MSI 032	MSI 040	MSI 055
n_{max}	[min ⁻¹]	19 800	11 550	5 800
M_N	[Nm]	0.17	0.40	0.88
M_{max}	[Nm]	1.00	1.50	3.00
$J_M + J_{Br}$	[10 ⁻⁶ kgm ²]	2.5 + 1.0	6.2 + 1.0	32 + 2.2
M_{Br}	[Nm]	0.4	0.4	0.7
m	[kg]	0.48	0.82	1.41

Motor types and part numbers MSI servomotors

Motor type		Part number
MSI-032H	without holding brake	8611-076-03
MSI-032H	with holding brake	8611-077-03
MSI-040H	without holding brake	8611-078-03
MSI-040H	with holding brake	8611-079-03
MSI-055H	without holding brake	8611-080-03
MSI-055H	with holding brake	8611-081-03

All motors with absolute rotary encoder

Rexroth – Precision Modules PSK

Mounting

General information

⚠ Do not mount the Precision Module by the end blocks!
The frame is the main stress-bearing structure!

Precision Modules can be mounted either by screwing the frame directly onto the base or by using clamping fixtures. When mounting the Precision Modules, observe the maximum tightening torque values as indicated in the table.

Mounting with screws in the frame

The reference edge on the frame facilitates alignment of the Precision Modules.

Suitable for cover options:

- without cover
 - with cover plate (remove cover plate before mounting the module).
- For installation dimensions, refer to the respective dimension drawings.

Mounting with clamping fixtures

The reference edge cannot be used in the region of the clamping fixtures.
Suitable for all cover options.

Clamping fixtures

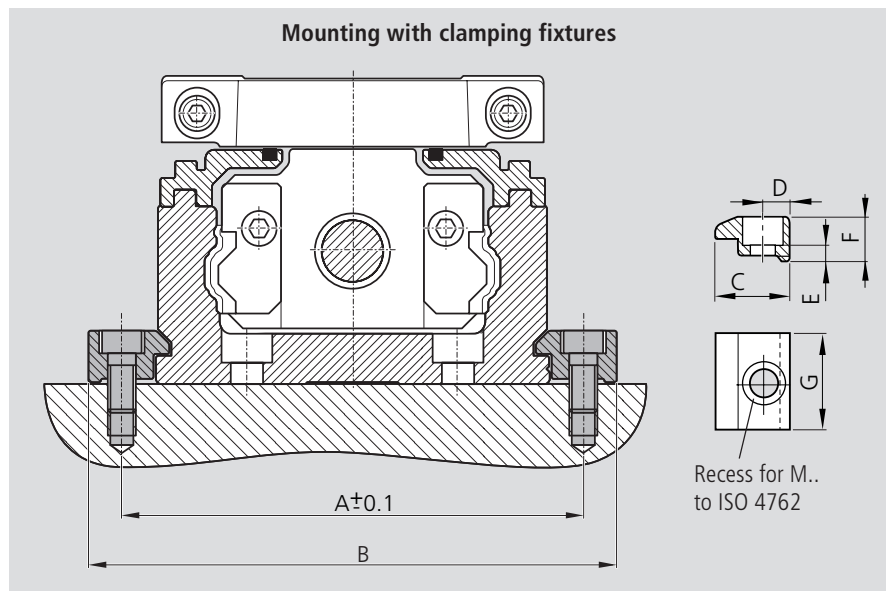
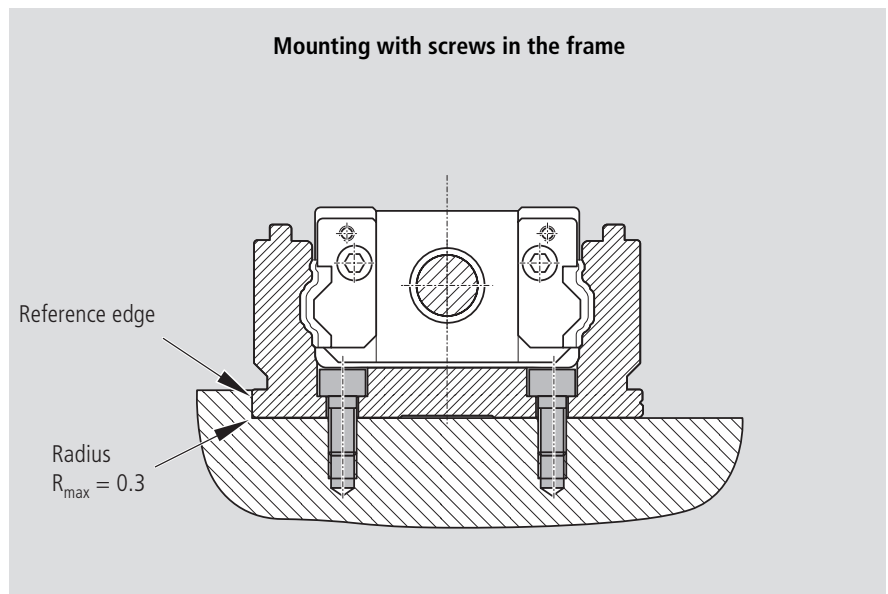

Recommended number of clamping fixtures: 3 per 500 mm and side



	Part numbers	Dimensions (mm)							
		A	B	C	D	E	F	G	M
PSK 50	1419-010-02	60	70	12.5	5.0	4.0	8.5	20.0	M4
PSK 60	1419-010-01	72	85	15.0	6.5	4.8	10.0	22.0	M5
PSK 90	1419-010-00	100	115	17.50	7.5	5.8	12.0	25.0	M6

Tightening torques of the mounting screws

with friction factor 0.125
Strength class 8.8

	8.8	M3	M4	M5	M6
	Nm	1.3	2.7	5.5	9.5

Rexroth – Precision Modules PSK

Lubrication Ports

General notes

The lubrication system on Precision Modules has been designed for grease lubrication. The lube port supplies lubricant to both the Rail System guideway and the Precision Ball Screw Assembly. If the module has two carriages, **both** of these must be lubricated.

Without cover

- One-point lubrication at either of the two funnel-type lube nipples DIN 3405-D3 per carriage.
- Lubrication through customer-built attachment: One-point lubrication through the customer-built attachment can be achieved by using the lube port in the carriage. The modules are shipped with the lube ports closed with set screws. Before using the lube ports, the set screws must be removed and O-rings inserted to seal off the customer-built attachment.

	PSK50	PSK60	PSK90
A	–	16.0	24.6
B	18.2	22.0	33.3
C	6.5	9.0	12.0
dia. D	2.5	2.5	4.0
dia. E	5.0	5.0	8.0
F	0.6 ^{+0.1}	0.7 ^{+0.1}	0.5 ^{+0.1}
M	M2.5	M3	M4

	O-ring DIN 3771	Part number
PSK 50	3 x 1	8411-118-01
PSK 60	3 x 1	8411-118-01
PSK 90	5 x 1.5	8411-108-01

Cover plate, sealing strip

One-point lubrication at either of the two funnel-type lube nipples DIN 3405-D3 per carriage.

Please contact us regarding the lubrication for short stroke applications:

PSK 50:	stroke < 70 mm
PSK 60:	stroke < 95 mm
PSK 90:	stroke < 135 mm

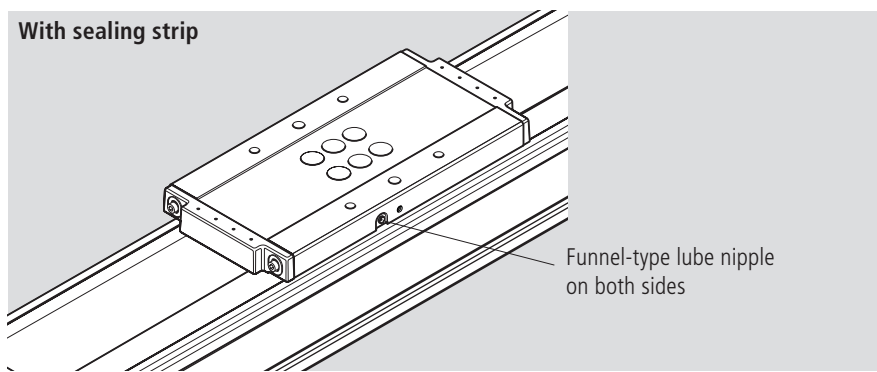
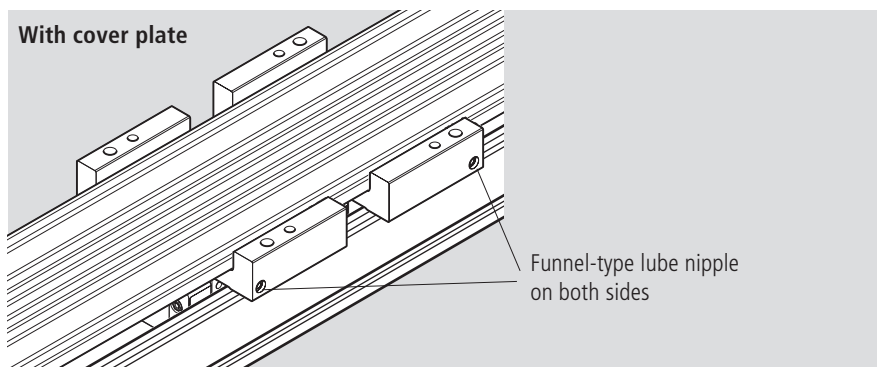
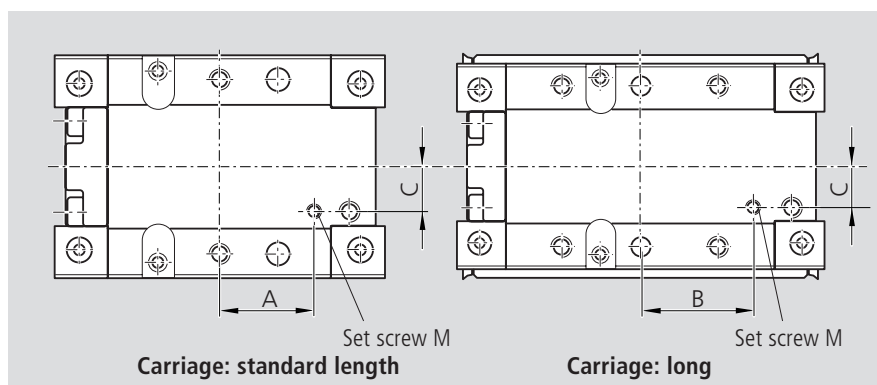
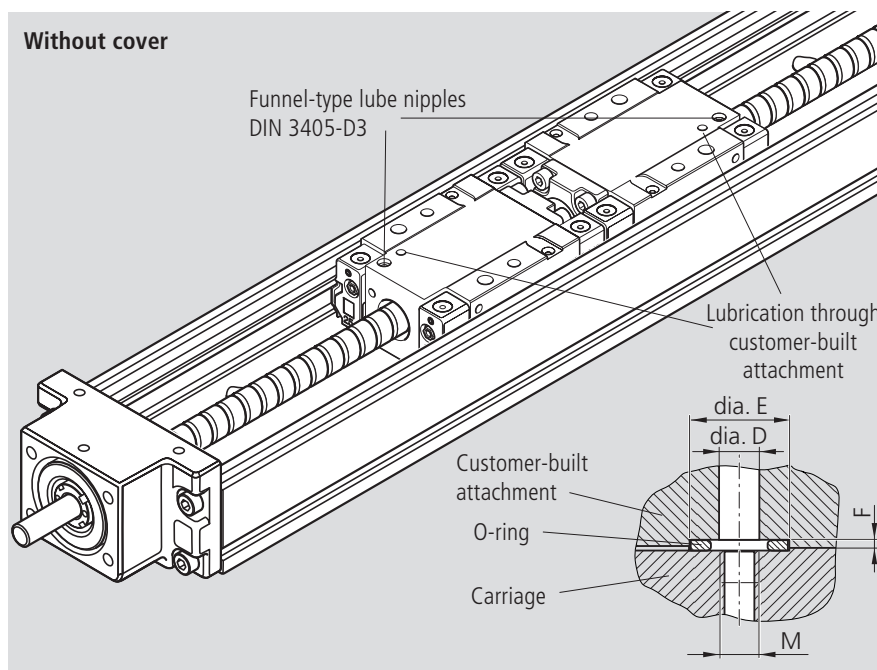

Rexroth – Precision Modules PSK

Documentation

Standard report

Option 01

The standard report serves to confirm that the checks listed in the report have been carried out and that the measured values lie within the permissible tolerances.

Checks listed in the standard report:

- Functional checks of mechanical components
- Functional checks of electrical components
- Design is in accordance with order confirmation.

Moment of friction measurement of complete system

Option 02

The moment of friction is measured along the entire travel range.

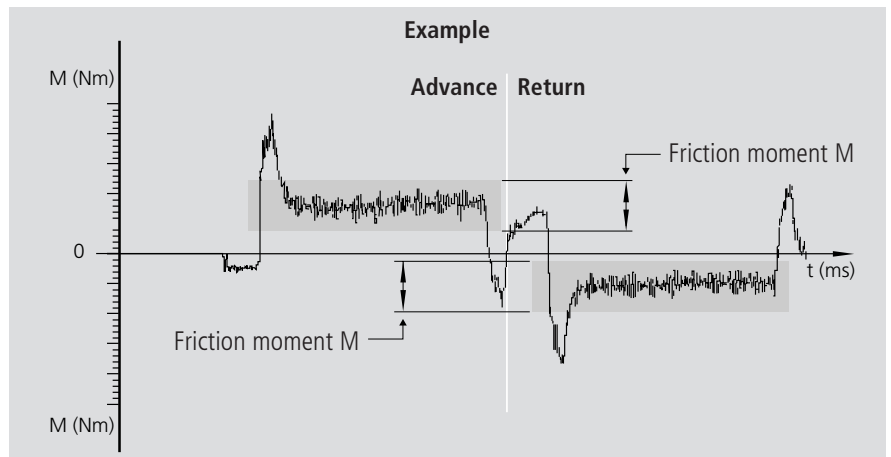

Lead deviation of ball screw

Option 03

A measurement report in table form is provided in addition to the graph (see illustration).

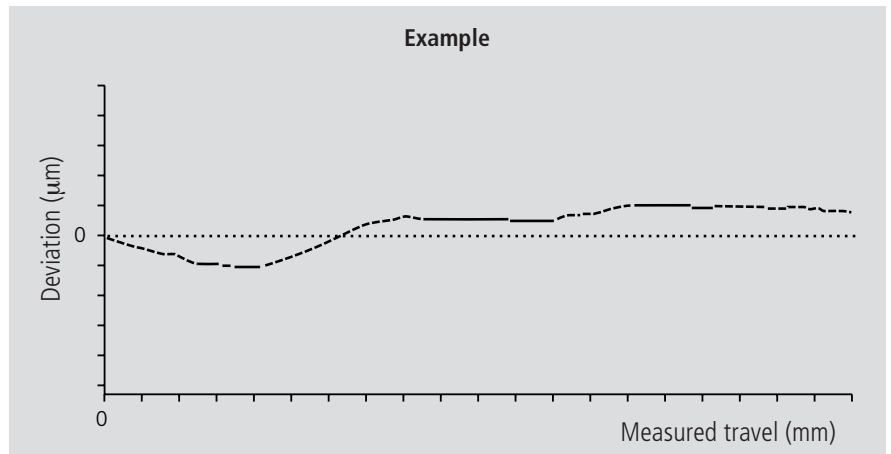

Running accuracy

Option 04

Yawing

Yawing describes the angular deviation about the vertical axis. This angular deviation is converted to a deviation in mm for a basic length and plotted in a graph. The basic length is indicated in the graph.

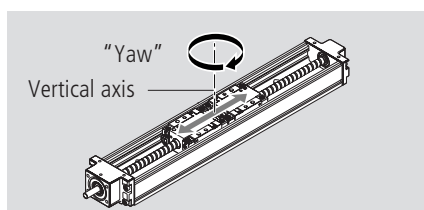

Several measurement points are approached along the travel and the yawing and pitching deviations are measured at these points.

Note:

The measurements are taken with the module screwed down and assuming an ideally flat mounting base surface.

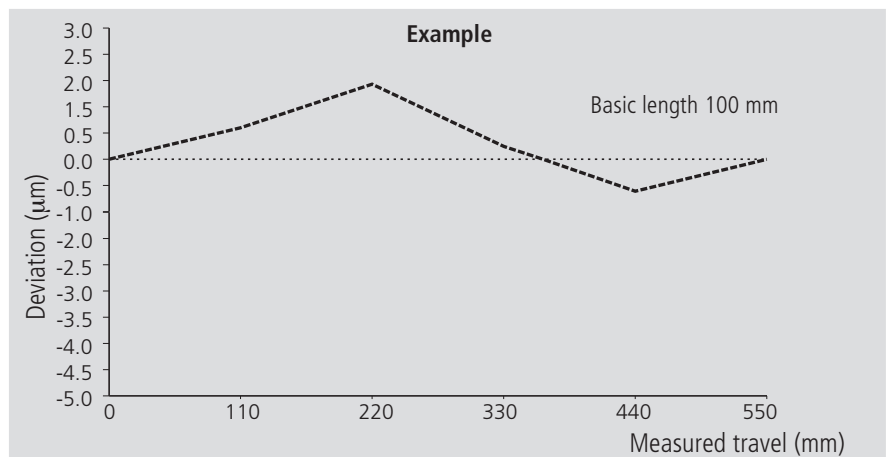

Rexroth – Precision Modules PSK

Documentation

Pitching

Pitching describes the angular deviation about the horizontal axis. This angular deviation is converted to a deviation in mm for a basic length and plotted in a graph. The basic length is indicated in the graph.

A measurement report in table form is provided in addition to the graphs (see yawing and pitching curves).

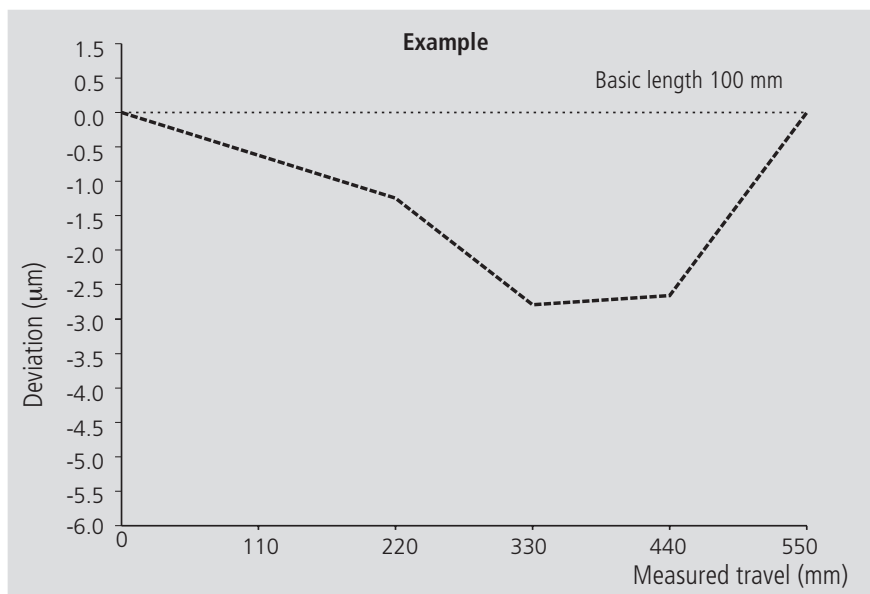
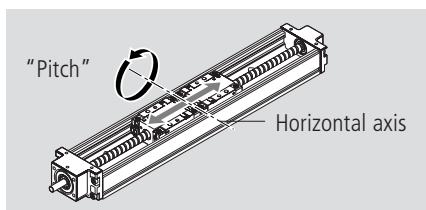

Positioning accuracy

to VDI/DGQ 3441

Option 05

Measurement points are selected at irregular intervals along the travel. This allows even periodical deviations to be detected during positioning.

Each measurement point is approached several times from both sides.

This gives the following parameters:

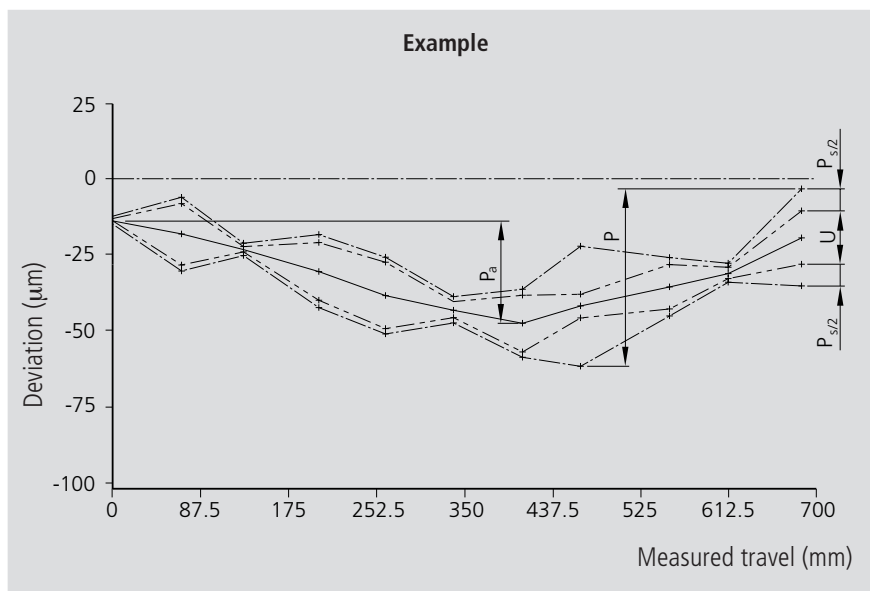

Positioning accuracy P

The positioning accuracy corresponds to the total deviation. It encompasses all the systematic and random deviations during positioning.

The positioning accuracy takes the following characteristic values into consideration:

- Position deviation
- Reversal range
- Position variation range

Position deviation P_a

The position deviation corresponds to the maximum difference arising in the mean values of all the measurement points. It describes systematic deviations.

Position variation range P_s

The position variation range describes the effects of random deviations. It is determined at every measurement point.

Reversal range U

The reversal range corresponds to the difference in mean values of the two approach directions. The reversal range is determined at every measurement point. It describes systematic deviations.

Inquiry/Order Form

Bosch Rexroth AG
Linear Motion and Assembly Technologies
D-97419 Schweinfurt, Germany

Telephone +49-9721-937-0
Telefax +49-9721-937-350
(direct)

Rexroth – Precision Module PSK

Ordering Data		Description
Ordering example: Precision Module PSK		
Precision Module PSK 90 (Part number): 1465-400-00, 740 mm		Designation PSK 90, preferred length = 740 mm
Type = MF01		with motor mount and motor, assembled as per diagram MF01
Guideway = 18		rail system
Drive unit = 03		ball screw 16 x 16
Carriage = 24		two carriages, long, steel version for cover plate
Motor attachment = 03		with motor mount for motor MKD 41B
Motor = 10		motor MKD 41B
Cover = 01		with cover plate
1st switch = 22-L		Hall sensor, for mounting on the left side
2nd switch = 21-L		Reed contact, for mounting on the left side
3rd switch = 22-L		Hall sensor, for mounting on the left side
Cable duct = 25		cable duct supplied loose
Switching cam = 30		switching cam for version without cover and with cover plate
Documentation = 01		standard report

To be completed by customer: Inquiry / Order

Precision Module PSK _____

(Part number): _____ - _____ - _____, length _____ mm

Type =
Guideway =
Drive unit =
Carriage =
Motor attachment =
Motor =
Cover =
1st switch = - + mm
2nd switch = - ± mm
3rd switch = - - mm
Cable duct = , mm
Switching cam =
Documentation =

Single parts:

(Part number): _____ - _____ - _____
 _____ - _____ - _____
 _____ - _____ - _____
 _____ - _____ - _____

Quantity: _____ pcs., _____ per month, _____ per year, per order, or _____

Remarks:

Sender

Company: _____
Address: _____

Name: _____
Department: _____
Phone: _____
Fax: _____

Bosch Rexroth AG
Linear Motion and
Assembly Technologies
Ernst-Sachs-Strasse 100
97424 Schweinfurt, Germany
Telephone +49-9721-937-0
Telefax +49-9721-937-275
(general)
Telefax +49-9721-937-350
(direct)
Internet www.boschrexroth.com/brl
e-mail info.brl@boschrexroth.de

Great care has been taken during the compilation of this publication to ensure all the information contained is accurate. We accept no responsibility however for any damage resulting from incorrect or incomplete information contained.

For deliveries and other services in the course of commercial business, the general terms and conditions for supplies and services contained in the valid price lists and the confirmations of order apply.

As our products are constantly in the process of further development, they are subject to alteration without notice.

STAR, Ball Rail and  are trademarks registered for Rexroth Star GmbH, Germany.

Roller Rail is a trademark of Rexroth Star GmbH, Germany.

Reproduction of this document, even in extract form, is only permitted with our approval.