

INDEX

TELESCOPIC RAIL: BEARINGS THAT MOVE OUTSIDE THE BOX.....	C4
PRODUCT OVERVIEW.....	C5
LOAD CAPACITIES.....	C6
WHAT MAKES ROLLON'S TELESCOPIC RAILS THE WORLD'S BEST?.....	C7
APPLICATIONS EXAMPLES.....	C8
DS SERIES.....	C10
DSS LOCKING SYSTEM.....	C12
DE SERIES.....	C14
DBN SERIES.....	C16
LTF44 SERIES.....	C18
ASN SERIES.....	C19
DMS63 SERIES.....	C22
PRODUCT SELECTION.....	C24
VERIFICATION OF STATIC LOAD.....	C25
SPEED.....	C25
OPENING AND CLOSING FORCE.....	C25
LIFETIME.....	C25
TECHNICAL APPLICATION SUGGESTIONS.....	C26
TEMPERATURE.....	C26
ANTICORROSIVE PROTECTION.....	C26
LUBRICATION.....	C26

TELESCOPIC RAIL: BEARINGS THAT MOVE OUTSIDE THE BOX

ROLLON's TELESCOPIC RAIL products are so different from existing drawer slides that we hesitate to call them by that name. The idea behind TELESCOPIC RAILS was to create a linear bearing that telescoped beyond its mounting structure. Our engineers had to think outside the box to do this since this sort of product really didn't exist.

Before ROLLON attacked the problem, drawer slides were simple, bent steel products suited for desk drawers, filing cabinets, keyboard trays and other light duty applications. In fields where high load capacities, reliability, low deflection, and smoothness of movement are important for a drawer slide-type extension, there has never really been a solution. Engineers were forced to use homemade solutions or to double up on thicker gauge bent steel drawer slides.

Drawer slides existed and linear bearings, of course, but drawer slides that could be used 24/7 with high loads and good precision were nowhere to be found. With our TELESCOPIC RAIL family, our engineers succeeded in creating a telescopic linear bearing – similar in movement to a drawer slide but in function closer to a linear bearing.

ROLLON's family of TELESCOPIC RAILS are the industry leader.

- ① TELESCOPIC RAIL products are made from cold-drawn bearing steel – never from bent sheet metal.
- ① TELESCOPIC RAIL products have hardened 60 HRc races to provide the smoothest movement at all times.
- ① TELESCOPIC RAIL work well with shocks and vibrations that render other slides inoperative immediately.
- ① TELESCOPIC RAIL products have minimal deflection at the tip of the fully extended slide – even while carrying maximum loads.
- ① TELESCOPIC RAIL products can reach strokes of over 2 m (6.5 ft) in one direction and can double that by doing the same out the other side.

The TELESCOPIC RAIL family contains the following types of products:

- Telescopic slides with hardened races
- Telescopic slides with non-hardened races
- Semi-telescopic slides with rails that extend more than half of their length out of either side of the fixed part of the slide.

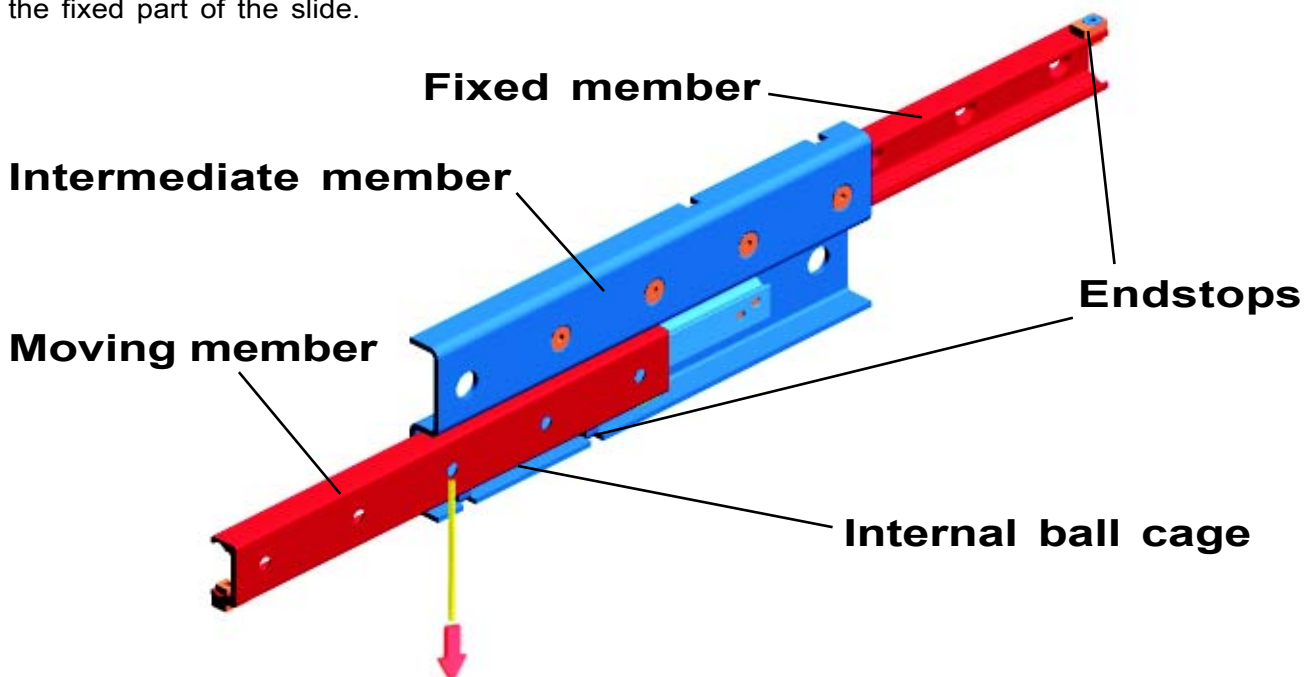

Note: This drawing refers to DS series.

PRODUCT OVERVIEW

All of the rails in the **TELESCOPIC RAIL** family are constructed from **cold-drawn carbon steel**. There are five different families which can be divided into completely telescopic slides with induction hardened races (**DS, DE, DBN**), completely telescopic slides without hardened races (**LTF44**), and semi-telescopic rails with induction hardened races (**ASN**).

• “DS” SERIES

This slide is formed by identical fixed and moving members with hardened raceways and an S-shaped intermediate member. This thin, space saving configuration gives the slides very high load capacities and rigidity.

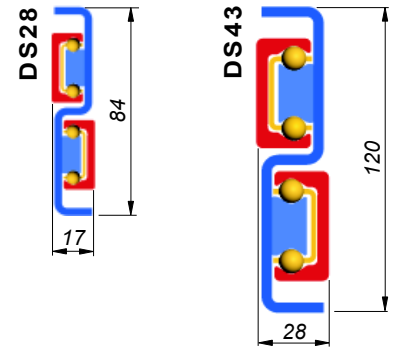

• “DE” SERIES

This slide is formed by identical fixed and moving members and an I-shaped intermediate member. This configuration's short, almost square, configuration gives the slides very rigid movements and very high radial load capacities.

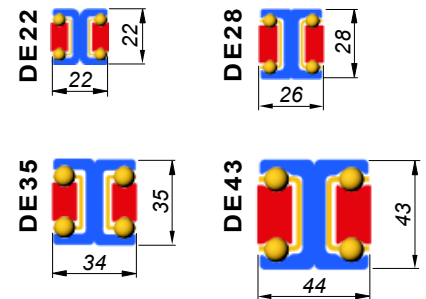

• “DBN” SERIES

This slide is formed by identical fixed and moving members with hardened, internal raceways and an almost square intermediate member. This compact configuration gives the slides similar load capacities for both radial and axial loads.

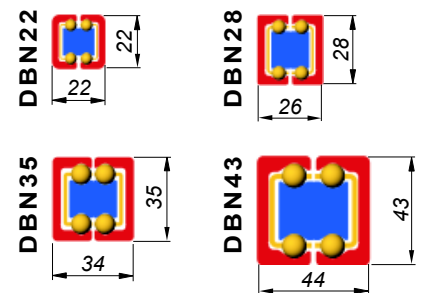

FULLY TELESCOPIC WITH NON-HARDENED RACES:

• “LTF44” SERIES

This slide is formed by a fixed member, an identical moving member and an S-shaped intermediate member. This non-hardened slide saves space due to its unique profile.

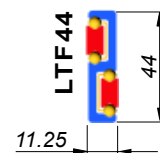

• “ASN” SERIES

This slide is formed by a fixed member and a differently shaped moving member. Both members have hardened raceways. This thin slide offers semi-telescopic movement. The moving member can extend over half its length out one side of the fixed member (it can also provide the same movement out the opposite side).

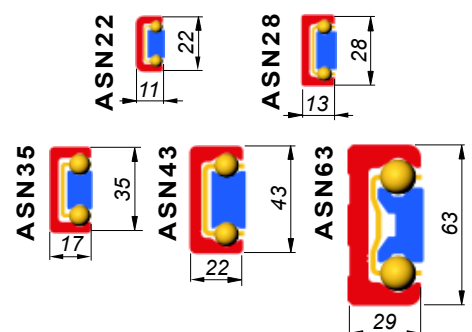

LOAD CAPACITIES

The load capacities listed below are calculated with the rails used in pairs, in their fully extended position and with the load applied in the center of mass of the moving members. Load capacities per pair are listed below in order to give an idea of the strength of the slides (Please see the following pages for a complete list of single rail load capacities).

The values in the tables refer to a pair of rails.

• “DS” SERIES

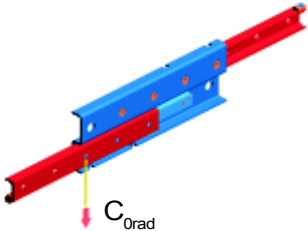

Rail type	Length	Stroke	2 x C _{0rad}
DS28	290	296	1140
DS28	1010	1034	4100
DS28	1490	1518	2800

Rail type	Length	Stroke	2 x C _{0rad}
DS43	530	556	4160
DS43	1010	1036	9240
DS43	1970	2026	5500

Note: Dimensions are in mm; “2 x C_{0rad}” is in newton and represents the maximum applicable load to a pair of rails.

• “DE” SERIES

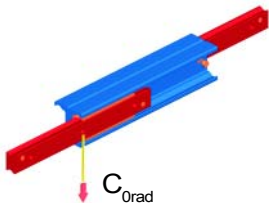

Rail type	Length	Stroke	2 x C _{0rad}
DE22	130	152	240
DE22	770	788	802
DE28	210	232	868
DE28	1010	1034	1184

Rail type	Length	Stroke	2 x C _{0rad}
DE35	210	254	798
DE35	1010	1038	2466
DE43	210	246	1226
DE43	1010	1036	4728

Note: Dimensions are in mm; “2 x C_{0rad}” is in newton and represents the maximum applicable load to a pair of rails.

• “DBN” SERIES

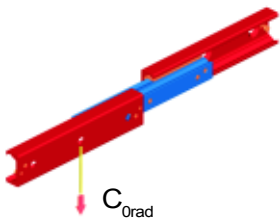

Rail type	Length	Stroke	2 x C _{0rad}
DBN22	130	152	240
DBN22	770	788	190
DBN28	210	232	868
DBN28	1010	1034	356

Rail type	Length	Stroke	2 x C _{0rad}
DBN35	210	254	798
DBN35	1010	1038	432
DBN43	210	246	1226
DBN43	1010	1036	1308

Note: Dimensions are in mm; “2 x C_{0rad}” is in newton and represents the maximum applicable load to a pair of rails.

• “LTF44” SERIES

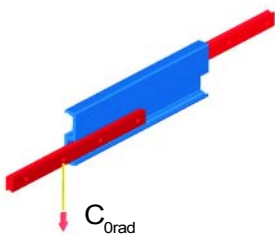

Rail type	Length	Stroke	2 x C _{0rad}
LTF44	200	210	228
LTF44	500	510	624

Rail type	Length	Stroke	2 x C _{0rad}
LTF44	750	760	948
LTF44	1000	1010	1296

Note: Dimensions are in mm; “2 x C_{0rad}” is in newton and represents the maximum applicable load to a pair of rails.

• “ASN” SERIES

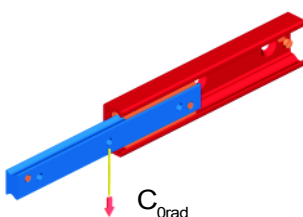

Rail type	Length	Stroke	2 x C _{0rad}
ASN22	130	76	644
ASN22	770	394	5956
ASN28	210	116	2662
ASN28	1010	517	13736
ASN35	210	127	2130
ASN35	1010	519	17348

Rail type	Length	Stroke	2 x C _{0rad}
ASN43	210	123	3300
ASN43	1010	518	25052
ASN43	1970	1013	48780
ASN63	610	333	22188
ASN63	1010	533	43250
ASN63	1970	1013	89780

Note: Dimensions are in mm; “2 x C_{0rad}” is in newton and represents the maximum applicable load to a pair of rails.

WHAT MAKES ROLLON'S TELESCOPIC RAILS THE WORLD'S BEST

- SMOOTHNESS OF MOVEMENT

When choosing a telescopic slide, this key factor is often overlooked. This is unfortunate because, in the field, it is often the most important factor. After all, a slide that moves poorly is at best, frustrating and at worst, dangerous.

Smoothness of movement is an area where **ROLLON's TELESCOPIC RAIL** slides excel. In fact, a quick analysis of the slides' characteristics reveals that the **induction hardened races** allow **smooth and sturdy movement** even at the **maximum capacity** listed in the catalog. The hardened raceways allow this same **sweet movement even when impacts, shocks, and vibrations are present**. This type of smoothness is difficult to obtain from slides made from bent sheet metal or aluminum under the best of circumstances and is near impossible to in active environments. The non-hardened raceways of lesser quality slides will tend to permanently deform or brinell in typical applications which will cause difficult, uneven movement or even failure. **ROLLON's TELESCOPIC RAIL** slides are rigid enough to allow only **minimal deflection at maximum capacity** (see below). This is important because when closing a slide, if there is deflection, the applied load must be pushed up an inclined plane. **TELESCOPIC RAIL** slides provide such smooth movement, there really is no other choice.

- HIGH LOAD CAPACITY

The load capacity is clearly one of the most important factors evaluated when choosing a telescopic slide. **ROLLON's TELESCOPIC RAIL** slides **combine high load capacity with compact dimensions**. Many drawer slide manufacturers present industrial slides in their catalogs and give them relatively high load capacities. This can cause confusion when compared to a **TELESCOPIC RAIL** slide with an obviously stiffer and higher quality design but with a similar capacity. It is therefore important to note that **the load capacities indicated in this catalog reflect the maximum working loads** that the slide will carry in a continuing, repetitive manner – ie. twenty-four hours a day, seven days a week. **ROLLON's TELESCOPIC RAIL** slides are actual telescopic linear bearings and not “drawer slides” and are therefore designed to be lasting, working components.

- EXTREMELY LIMITED DEFLECTION

All of the elements in the **TELESCOPIC RAIL** slides have been designed to remain as stiff as possible and to allow as little deflection as possible in the fully extracted position. As mentioned briefly above, **the smoothness of movement depends heavily on the lack of deflection in the extracted position**. The load on a slide that deflects when opened must be lifted and pushed up an inclined plane in order to close. Oversize actuators and motors that are often needed to compensate for this lifting and pushing movement do not need to be specified due to the **rigidity** provided by **ROLLON's TELESCOPIC RAIL** slides. The excessive manual labor and effort needed to move a deflecting drawer slide is certainly not needed to close a **TELESCOPIC RAIL** slide. The mechanical and economical advantages of our high-quality slides are notable.

- ASSEMBLING ACCURACY

ROLLON is able to guarantee **extreme quality, accuracy, and reliability** for all of the components of the **TELESCOPIC RAIL** family. Smooth movement, **lack of play**, and **low coefficient of friction** separate these rails from industrial “drawer slides” found elsewhere. When choosing a telescopic slide, there really is no other choice.

APPLICATION EXAMPLES

The slides in the **TELESCOPIC RAIL** family can be used in a multitude of application fields and in many different configurations. Although most typical applications use a pair of slides mounted parallel, the quality, high load capacities, and low deflection offered by these slides allow the design engineer an opportunity to creatively use other configurations to best solve an application.

TRAIN BATTERY EXTRACTION

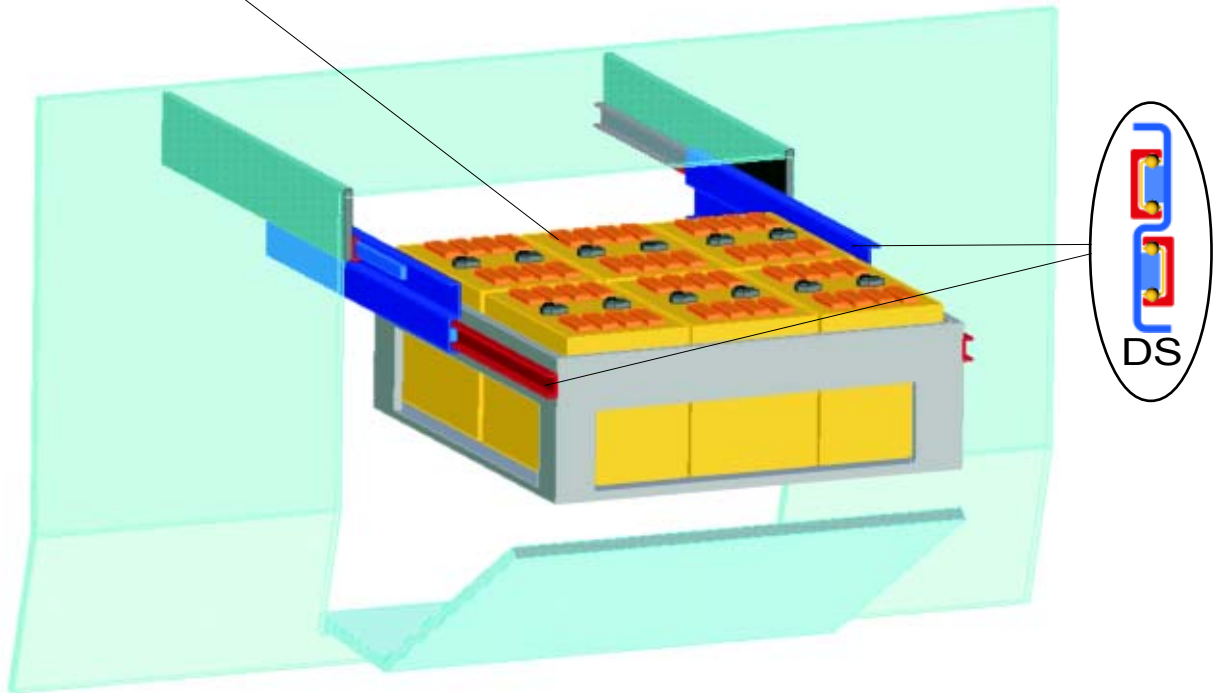

VEHICLE HANDICAP STEP

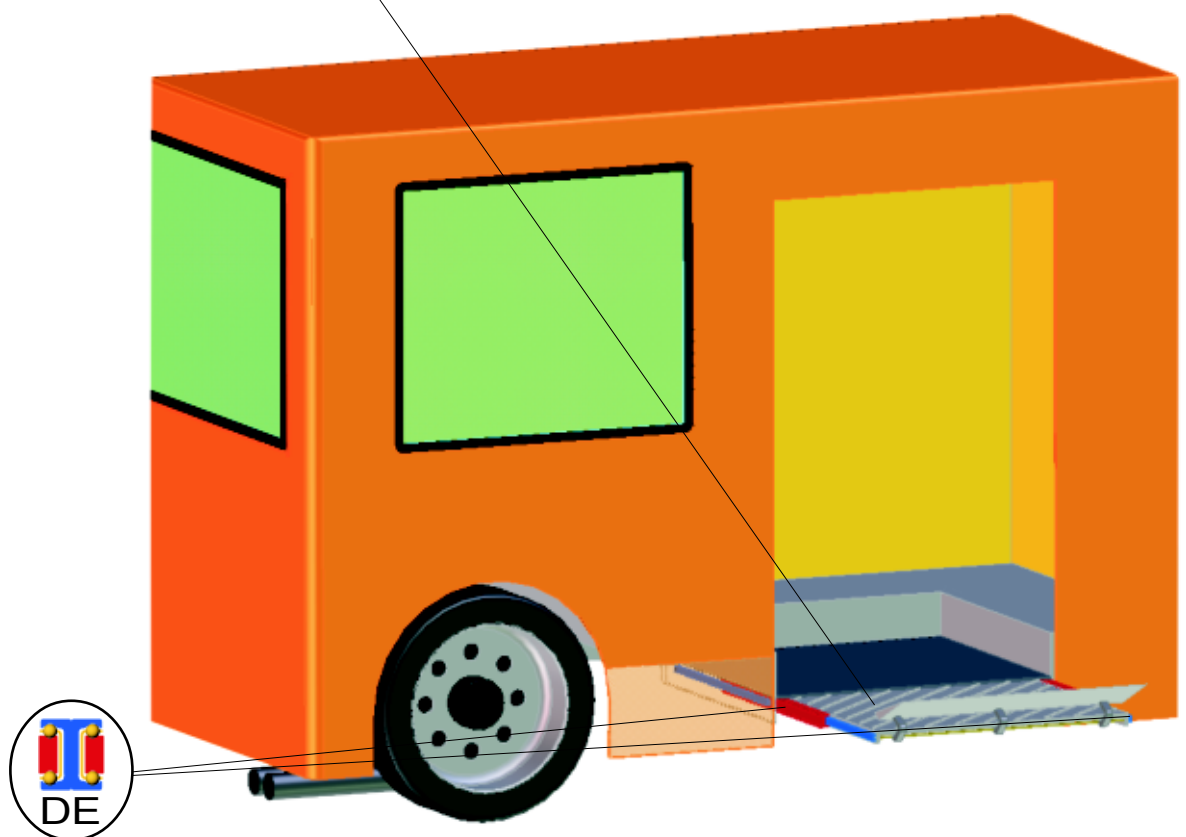

ELECTROMEDICAL BED

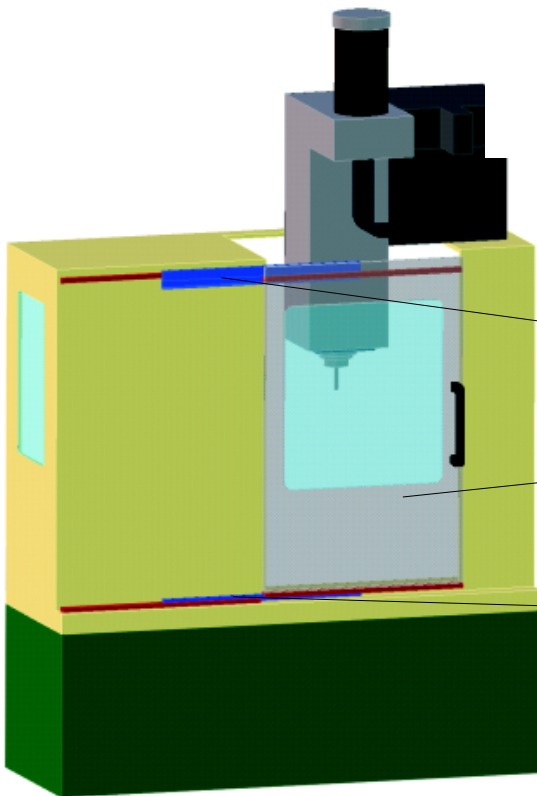
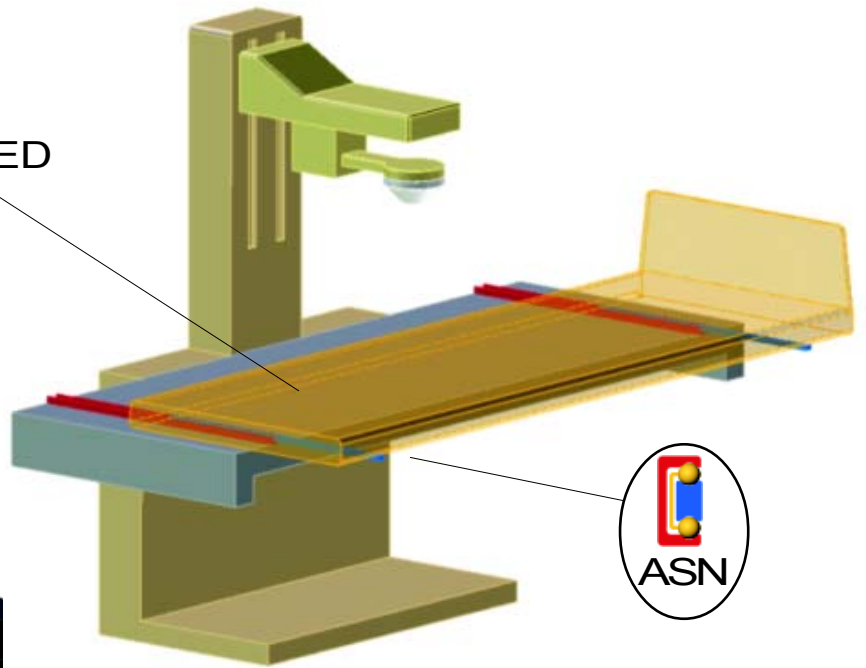

MACHINE TOOL DOOR ENCLOSURES

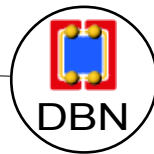

PRODUCT EXPOSITION UNITS

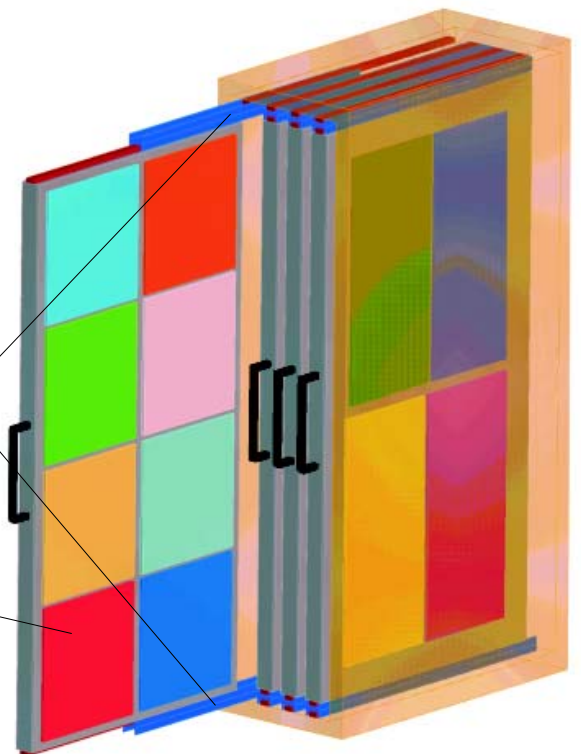

OTHER APPLICATION EXAMPLES:

- Train, subway, and light rail cars and buses: Internal and external door movements, extending luggage carriers, etc.
- Industrial automation: telescopic press arms, product extraction and retrieval systems, etc.
- Other sectors where it is necessary to extract, expand, move, or extend.

DS SERIES

The new **DS** series telescopic slide is formed by a fixed member and an identical moving member - both with hardened, internal raceways - and an **S-shaped intermediate member**. The characteristic S-shaped member gives the slide a very high moment of inertia of mass which in turn allows the slide to be very thin and yet **extremely strong and rigid**. This rigidity and high load capacity translates to **very low deflection** even when the rail is loaded and in a completely open position. This is true for both long and short strokes. The **DS** series is available in two sizes: size 28 and size 43. These sizes refer to the outside dimensions of the fixed and moving members of the slides.

The DS series rails have built in catches with rubber endstops that will stop the slide for slow manual movements. For fast or automatic movements, we suggest adding external endstops to the structure

The **DS** series rails are available with single direction or double direction strokes.

-Single direction stroke (version "S"). The moving member can extend out of only one side of the slide. It moves slightly more than its total length.

-Double direction stroke (Version "D"). The moving member can extend out of both sides of the slide. The movement allowed out each side is slightly less than the member's total length. It is important to note that the intermediate member of all "D" version slides can freely move slightly less than half its length in either direction when the slide is closed. When closing a "D" version slide, the return of the intermediate member is not automatic. When the moving element has started the stroke in the opposite direction, it will catch the intermediate member and force it to return. The members have catches with rubber endstops for this purpose.

PLEASE CONSIDER THAT INTERNAL CATCHES CANNOT BE USED TO BLOCK THE MOVING LOAD, EXTERNAL ENDSTOPS MUST BE ADDED!

The DS series slides are designed to be mounted so that the applied load acts in a radial direction in respect to the slide.

Upon request, slides with special length strokes can be ordered. For single direction stroke versions ("S" versions), special strokes can be up to 130% of the closed length of the slide while still maintaining high load capacities and low deflection. For more information, please contact our engineering department.

Order code:

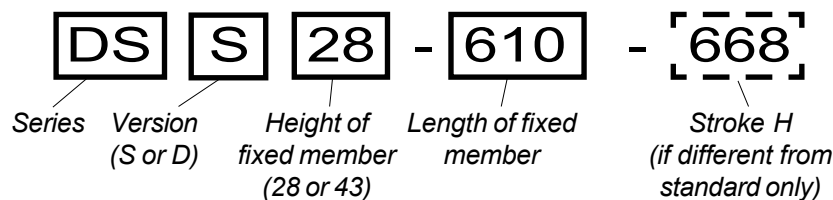

Note: For special versions, the stroke H can only vary from the standard values listed on the next page by a multiple of the following values:

DS..28...: 19 mm (Example: DSS28-930-969)

DS..43...: 30 mm (Example: DSS43-1010-1066)

Scale 1:1

DS28

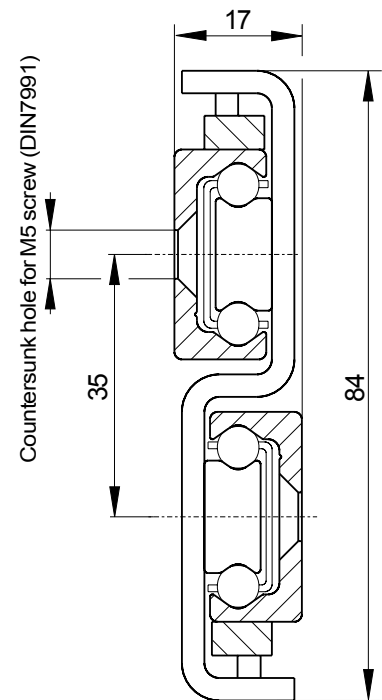

DS43

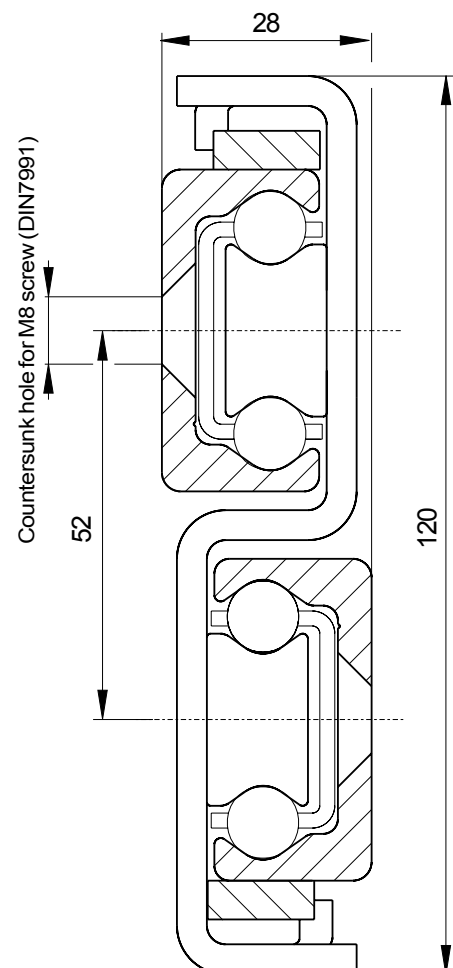

- Single direction stroke (version "S"):

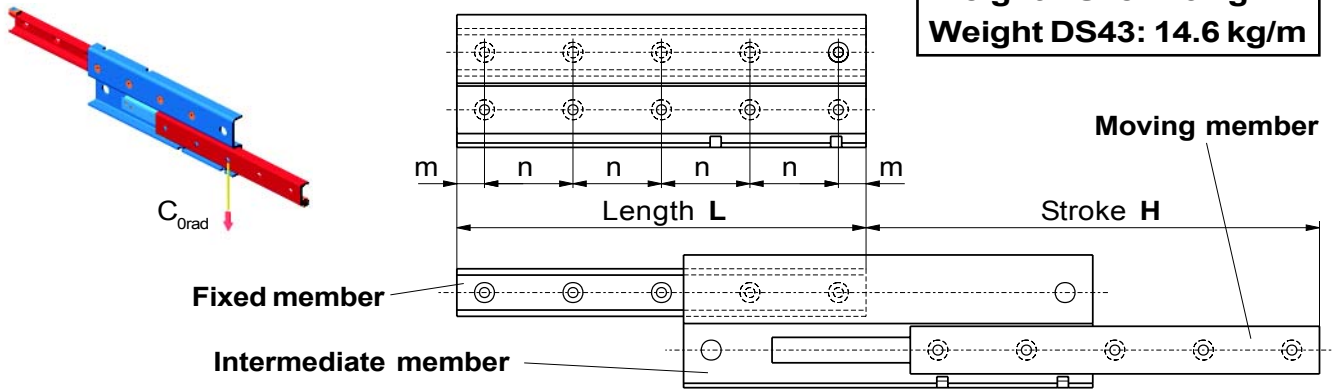

Order code	Stroke H [mm]	Fixed and moving member				C_{0rad} [N]
		L [mm]	m [mm]	n [mm]	No. holes	
DSS28-290	296	290	25	80	4	570
DSS28-370	380	370	25	80	5	770
DSS28-450	464	450	25	80	6	970
DSS28-530	548	530	25	80	7	1170
DSS28-610	630	610	25	80	8	1470
DSS28-690	714	690	25	80	9	1670
DSS28-770	798	770	25	80	10	1870
DSS28-850	864	850	25	80	11	2210
DSS28-930	950	930	25	80	12	2240
DSS28-1010	1034	1010	25	80	13	2050
DSS28-1170	1202	1170	25	80	15	1760
DSS28-1330	1350	1330	25	80	17	1580
DSS28-1490	1518	1490	25	80	19	1400

Note: Load C_{0rad} is intended for single telescopic rail

Order code	Stroke H [mm]	Fixed and moving member				C_{0rad} [N]
		L [mm]	m [mm]	n [mm]	No. holes	
DSS43-530	556	530	25	80	7	2080
DSS43-610	626	610	25	80	8	2620
DSS43-690	726	690	25	80	9	2800
DSS43-770	796	770	25	80	10	3350
DSS43-850	866	850	25	80	11	3900
DSS43-930	966	930	25	80	12	4060
DSS43-1010	1036	1010	25	80	13	4620
DSS43-1170	1206	1170	25	80	15	4610
DSS43-1330	1376	1330	25	80	17	4030
DSS43-1490	1516	1490	25	80	19	3710
DSS43-1650	1686	1650	25	80	21	3320
DSS43-1810	1856	1810	25	80	23	3010
DSS43-1970	2026	1970	25	80	25	2750

Note: Load C_{0rad} is intended for single telescopic rail

- Double direction stroke (version "D"):

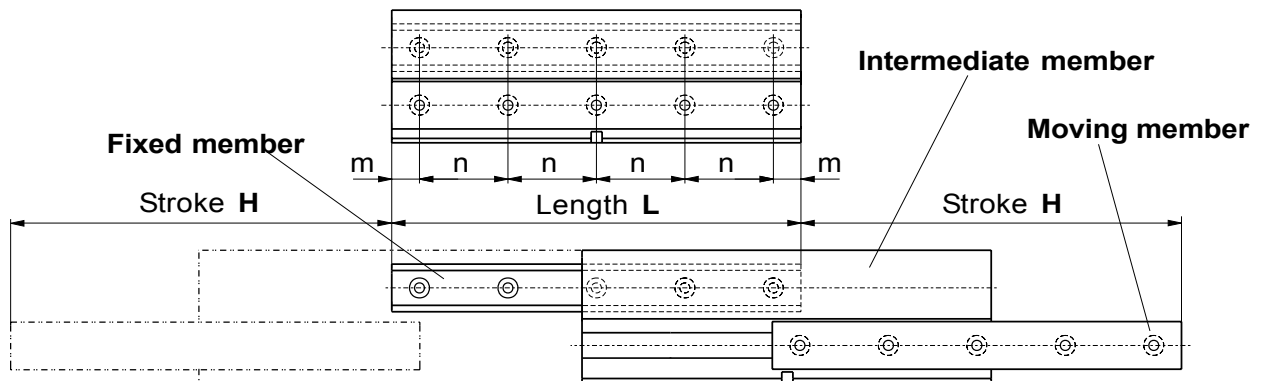

Order code	Stroke H [mm]	Fixed and moving member				C_{0rad} [N]
		L [mm]	m [mm]	n [mm]	No. holes	
DSD28-290	246	290	25	80	4	1030
DSD28-370	326	370	25	80	5	1210
DSD28-450	406	450	25	80	6	1530
DSD28-530	486	530	25	80	7	1730
DSD28-610	566	610	25	80	8	1940
DSD28-690	646	690	25	80	9	2150
DSD28-770	726	770	25	80	10	2360
DSD28-850	806	850	25	80	11	2670
DSD28-930	866	930	25	80	12	2710
DSD28-1010	966	1010	25	80	13	2360
DSD28-1170	1126	1170	25	80	15	2010
DSD28-1330	1286	1330	25	80	17	1750
DSD28-1490	1446	1490	25	80	19	1550

Note: Load C_{0rad} is intended for single telescopic rail

Order code	Stroke H [mm]	Fixed and moving member				C_{0rad} [N]
		L [mm]	m [mm]	n [mm]	No. holes	
DSD43-530	476	530	25	80	7	3020
DSD43-610	556	610	25	80	8	3550
DSD43-690	636	690	25	80	9	4090
DSD43-770	716	770	25	80	10	4300
DSD43-850	796	850	25	80	11	4830
DSD43-930	876	930	25	80	12	5370
DSD43-1010	956	1010	25	80	13	5580
DSD43-1170	1116	1170	25	80	15	5390
DSD43-1330	1276	1330	25	80	17	4690
DSD43-1490	1436	1490	25	80	19	4140
DSD43-1650	1596	1650	25	80	21	3710
DSD43-1810	1756	1810	25	80	23	3360
DSD43-1970	1916	1970	25	80	25	3080

Note: Load C_{0rad} is intended for single telescopic rail

“DSS” LOCKING SYSTEM

(only for closed position)

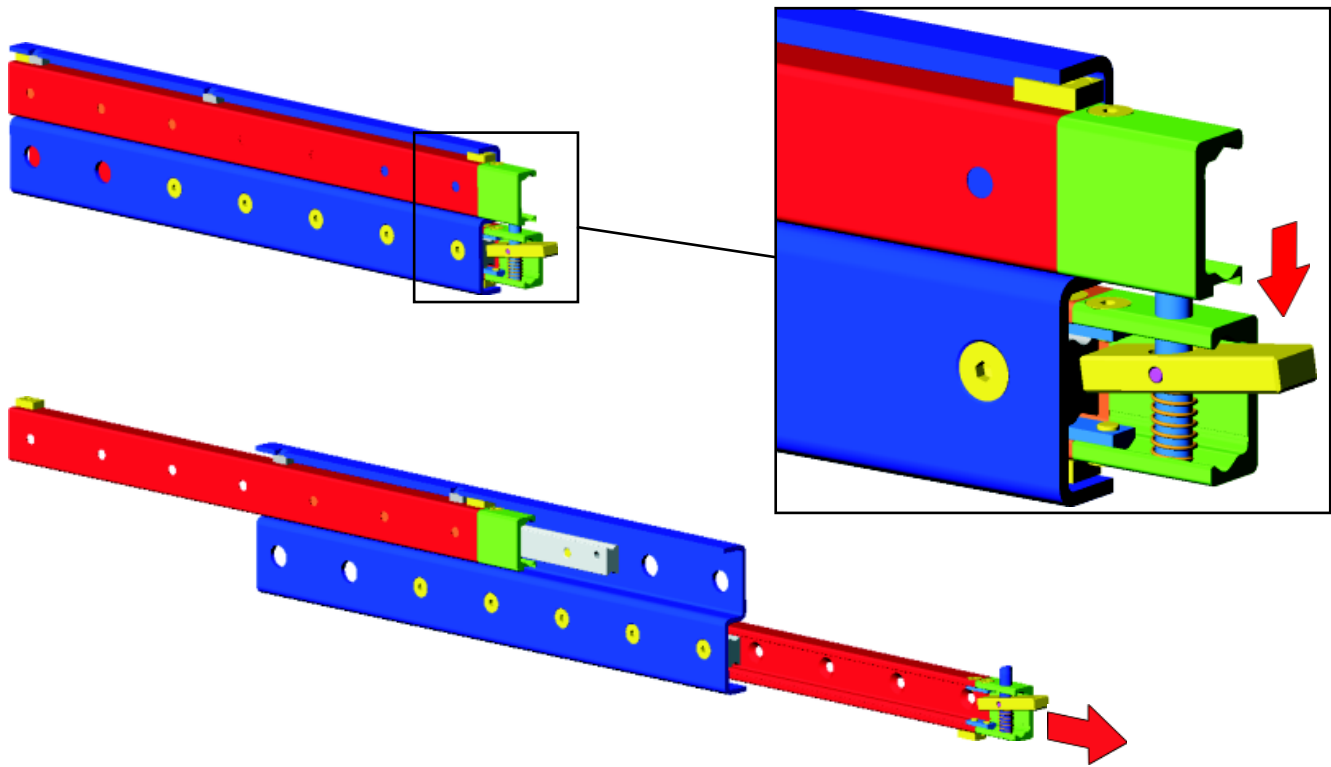

The **DSS** series **TELESCOPIC RAIL** heavy duty drawer slide comes with end-stops in the completely open and closed position. While these stops are designed to stop the slide from over extending in manual movements, they will not stop any external forces such as vibrations or inclined planes from moving the loaded slide.

In many applications it is necessary to block the rails in place in a completely closed position. Most applications in the transportation sector have this need. Whether train, bus, camper, naval, or military applications, there is frequently a need to have slide movement blocked during vehicle movement and released only when desired.

Our robust blocks are able to stop elevated longitudinal forces of up to a 3G acceleration with the maximum loads (over 2100 lbs) applied to a pair of rails. The stops themselves are simple: push down the lever and free the slide from the closed position. Like the slides, the locks are **zinc plated** but can be ordered with **chemical nickel plating** for elevated corrosion resistance.

TECHNICAL DATA:

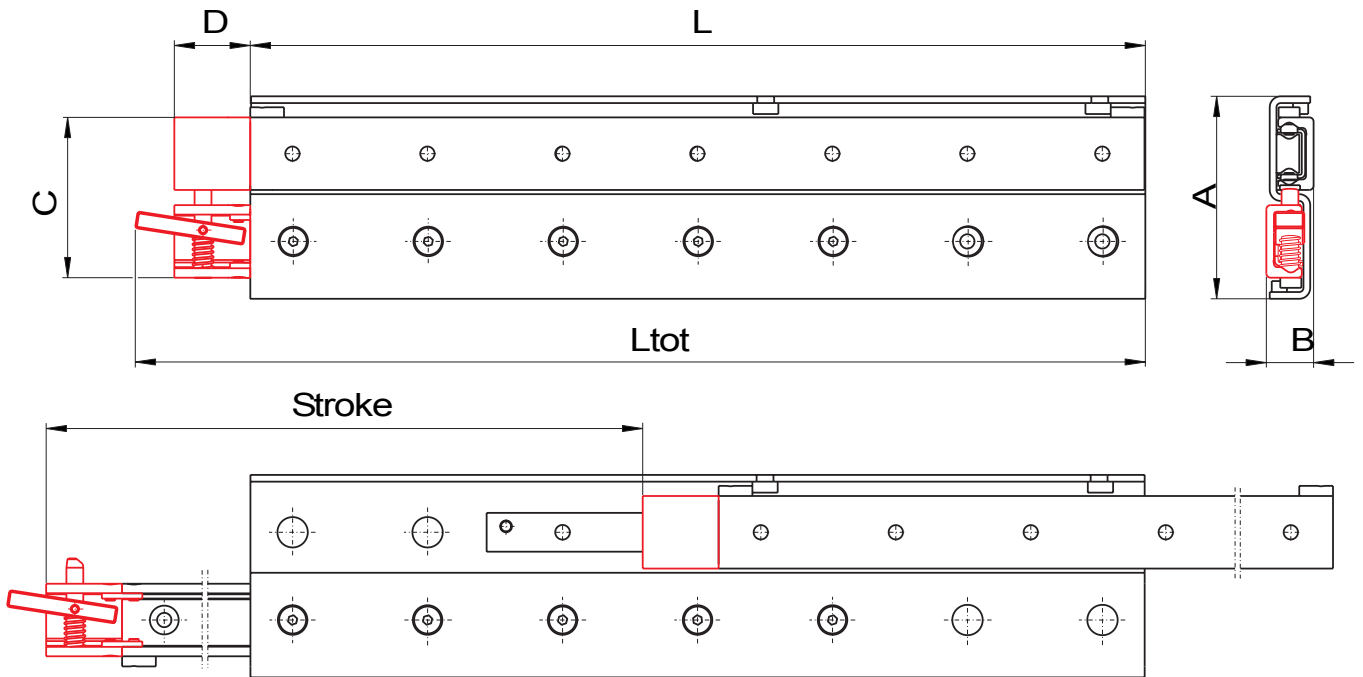

Type	L	Ltot	A	B	C	D
DSB28	from 290 to 1490*	L + 52	84	17	63	35
DSB43	from 530 to 1970*	L + 69	120	28	95	45

* For more information including information about our DSS heavy duty drawer slides (Telescopic Rail), please see page C11. Please also feel free to contact our Application Engineering Department.

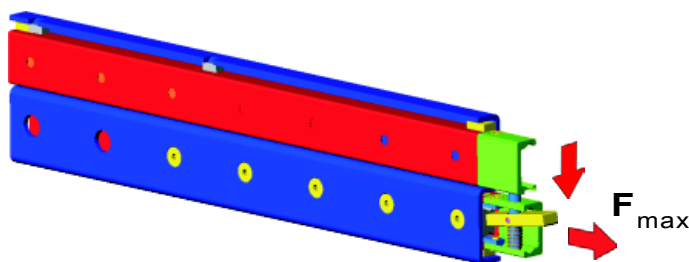

Type	F _{max} (N)
DSB28	2460
DSB43	5630

Order code (rail with locking system):

DS
B
28
-
610
-
668

Series Version with locking system Height of fixed member (28 or 43) Length of fixed member Stroke (if different from standard only)

Application examples:

- Trains: battery cages, doors
- Electronic racks
- Military
- Naval

DE SERIES

This slide is formed by identical fixed and moving members and an **I-shaped intermediate member** and is almost square. The I-shaped intermediate member allows the rails to carry high loads especially when the load is applied in a radial direction (referring to the drawings at right, the load would be vertical). The load capacity for loads applied axially is lower. When mounted, this slide offers a single direction stroke equal to slightly more than the closed length. Please consult our engineering department for more information.

Both the fixed and moving element can be supplied with **countersunk mounting holes (as in the drawings at right)** by indicating the letter "V" when ordering or with **threaded through holes (M4 for DE22, M5 for DE28, M6 for DE35 and M8 for DE43)** by indicating the letter "F" when ordering.

A **double direction stroke** is obtainable by removing the endstop screws at the end of each side of the intermediate member. The slide will not disassemble with the removal of these screws due to a system of built-in pins. (Although the pins are strong enough to stop the ballcage and to return the intermediate member, they are not designed to stop a moving member carrying a load. **External endstops must be added for this purpose**). It is important to note that when the endstop screws are removed, the intermediate member can freely move slightly more than half its length out either side. When closing a **DE** slide with the endstop screws removed, the return of the intermediate member is not automatic. When the moving element has started the stroke in the opposite direction, it will catch the intermediate member and force it to return.

The stroke H listed on the next page refers to a single direction stroke. With the endstop screws removed as explained above, the stroke is equal to 2H.

Upon request, slides with special length strokes can be ordered. Special strokes can be up to 130% of the closed length of the slide while still maintaining high load capacities and low deflection.

For more information, please contact our engineering department.

Scale 1:1

DE22

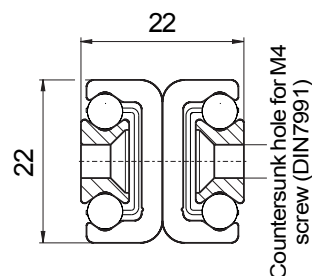

DE28

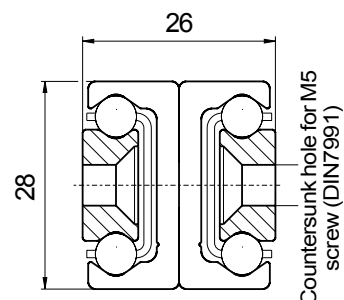

DE35

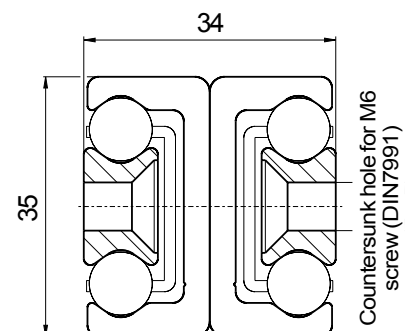

DE43

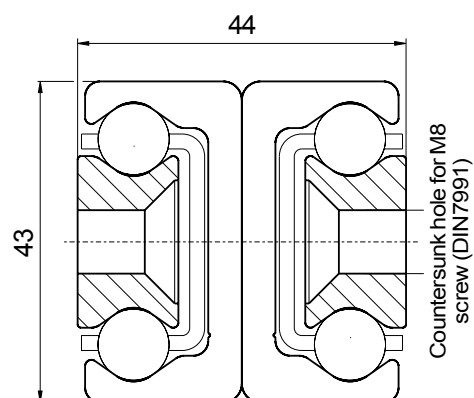

Order codes:

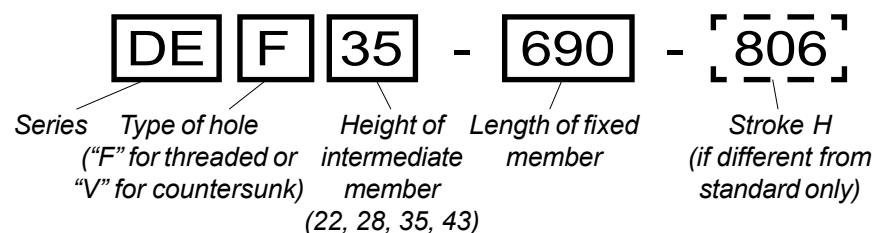

Note: For special versions, the stroke H can only vary from the standard values listed on the next page by a multiple of the following values:

DE..22....: 15 mm (Example: DEF22-210-237)

DE..35....: 24 mm (Example: DEV35-450-518)

DE..28....: 19 mm (Example: DEV28-290-315)

DE..43....: 30 mm (Example: DEF43-930-996)

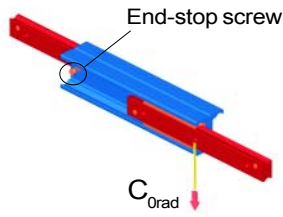

Weight DE22: 2.5 kg/m
Weight DE28: 4.0 kg/m
Weight DE35: 6.1 kg/m
Weight DE43: 10.5 kg/m

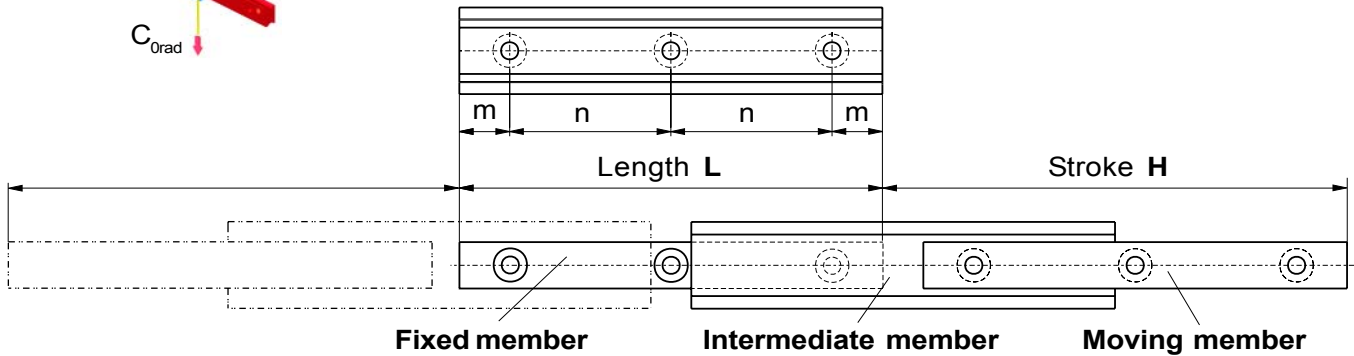

Order code	Stroke H [mm]	Fixed and moving member				C_{Orad} [N]
		L [mm]	m [mm]	n [mm]	No. holes	
DE..22-130	152	130	25	80	2	120
DE..22-210	222	210	25	80	3	282
DE..22-290	308	290	25	80	4	391
DE..22-370	392	370	25	80	5	503
DE..22-450	462	450	25	80	6	676
DE..22-530	548	530	25	80	7	571
DE..22-610	632	610	25	80	8	494
DE..22-690	702	690	25	80	9	453
DE..22-770	788	770	25	80	10	401

Note: Load C_{Orad} is intended for single telescopic rail

Order code	Stroke H [mm]	Fixed and moving member				C_{Orad} [N]
		L [mm]	m [mm]	n [mm]	No. holes	
DE..28-130	148	130	25	80	2	237
DE..28-210	232	210	25	80	3	434
DE..28-290	296	290	25	80	4	768
DE..28-370	380	370	25	80	5	972
DE..28-450	464	450	25	80	6	1170
DE..28-530	548	530	25	80	7	1107
DE..28-610	630	610	25	80	8	958
DE..28-690	714	690	25	80	9	844
DE..28-770	798	770	25	80	10	755
DE..28-850	864	850	25	80	11	713
DE..28-930	950	930	25	80	12	646
DE..28-1010	1034	1010	25	80	13	592
DE..28-1170	1202	1170	25	80	15	508

Note: Load C_{Orad} is intended for single telescopic rail

Order code	Stroke H [mm]	Fixed and moving member				C_{Orad} [N]
		L [mm]	m [mm]	n [mm]	No. holes	
DE..35-210	254	210	25	80	3	399
DE..35-290	318	290	25	80	4	792
DE..35-370	406	370	25	80	5	1014
DE..35-450	494	450	25	80	6	1236
DE..35-530	558	530	25	80	7	1666
DE..35-610	646	610	25	80	8	1887
DE..35-690	734	690	25	80	9	1689
DE..35-770	798	770	25	80	10	1591
DE..35-850	886	850	25	80	11	1425
DE..35-930	974	930	25	80	12	1291
DE..35-1010	1038	1010	25	80	13	1233
DE..35-1170	1214	1170	25	80	15	1044
DE..35-1330	1366	1330	25	80	17	937
DE..35-1490	1518	1490	25	80	19	850

Note: Load C_{Orad} is intended for single telescopic rail

Order code	Stroke H [mm]	Fixed and moving member				C_{Orad} [N]
		L [mm]	m [mm]	n [mm]	No. holes	
DE..43-210	246	210	25	80	3	613
DE..43-290	316	290	25	80	4	1125
DE..43-370	416	370	25	80	5	1310
DE..43-450	486	450	25	80	6	1839
DE..43-530	556	530	25	80	7	2388
DE..43-610	626	610	25	80	8	2949
DE..43-690	726	690	25	80	9	3104
DE..43-770	796	770	25	80	10	3054
DE..43-850	866	850	25	80	11	2847
DE..43-930	966	930	25	80	12	2506
DE..43-1010	1036	1010	25	80	13	2364
DE..43-1170	1206	1170	25	80	15	2022
DE..43-1330	1376	1330	25	80	17	1766
DE..43-1490	1516	1490	25	80	19	1628
DE..43-1650	1686	1650	25	80	21	1458
DE..43-1810	1856	1810	25	80	23	1320
DE..43-1970	2026	1970	25	80	25	1206

Note: Load C_{Orad} is intended for single telescopic rail

DBN SERIES

This slide is formed by identical fixed and moving members and an almost **square-shaped intermediate member**. This sturdy intermediate member allows the rail to be mounted with the load acting radially or axially while practically maintaining the same load capacity (listed on the next page as C_{0rad}). When mounted, this slide offers a single direction stroke equal to slightly more than the closed length.

A **double direction stroke** is obtainable by removing the endstop screws at the end of the fixed and moving members. The slide will not disassemble with the removal of these screws due to a system of built-in pins. (Although the pins are strong enough to stop the ballcage and to return the intermediate member, they are not designed to stop a moving member carrying a load. **External endstops must be added for this purpose**). It is important to note that when the endstop screws are removed, the intermediate member can freely move slightly more than half its length out either side. When closing a **DBN** slide with the endstop screws removed, the return of the intermediate member is not automatic. When the moving element has started the stroke in the opposite direction, it will catch the intermediate member and force it to return.

The stroke H listed on the next page refers to a single direction stroke. With the endstop screws removed as explained above, the stroke is equal to 2H.

Upon request, slides with special length strokes can be ordered. Special strokes can be up to 130% of the closed length of the slide while still maintaining high load capacities and low deflection. For more information, please contact our engineering department.

Scale 1:1

DBN22

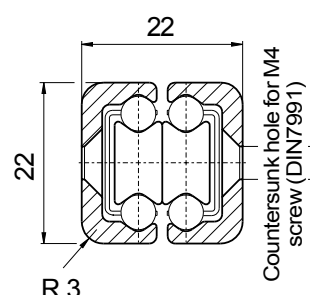

DBN28

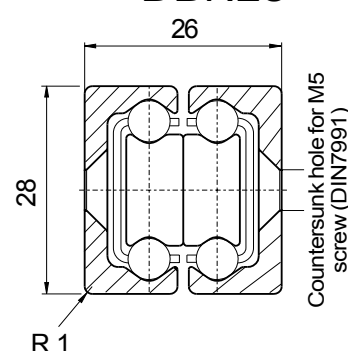

DBN35

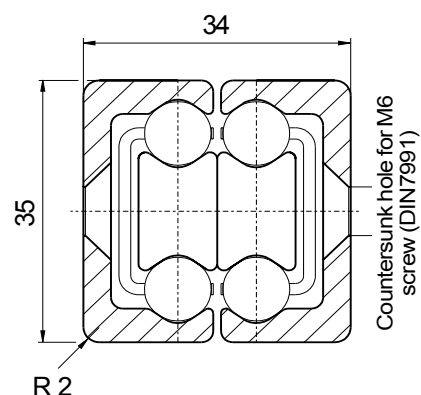

DBN43

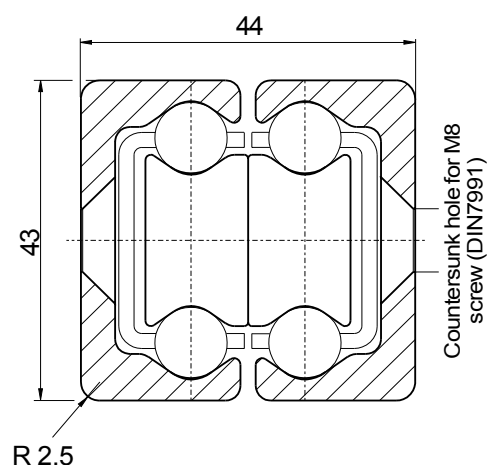

Order codes:

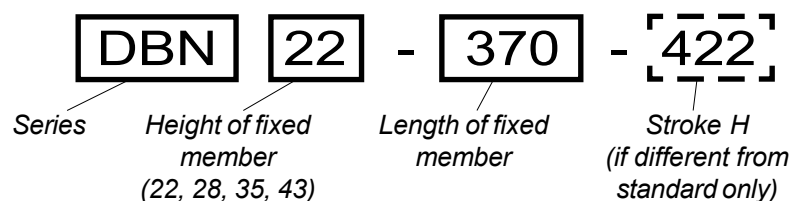

Note: For special versions, the stroke H can only vary from the standard values listed on the next page by a multiple of the following values:

- DBN22...: 15 mm (Example: DBN22-450-477)
- DBN28...: 19 mm (Example: DBN28-530-567)
- DBN35...: 24 mm (Example: DBN35-850-910)
- DBN43...: 30 mm (Example: DBN43-1170-1236)

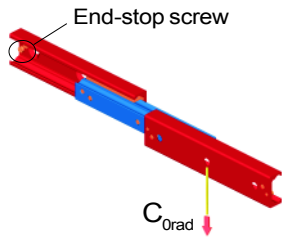

Weight DBN22: 2.5 kg/m
Weight DBN28: 4.0 kg/m
Weight DBN35: 6.3 kg/m
Weight DBN43: 11.1 kg/m

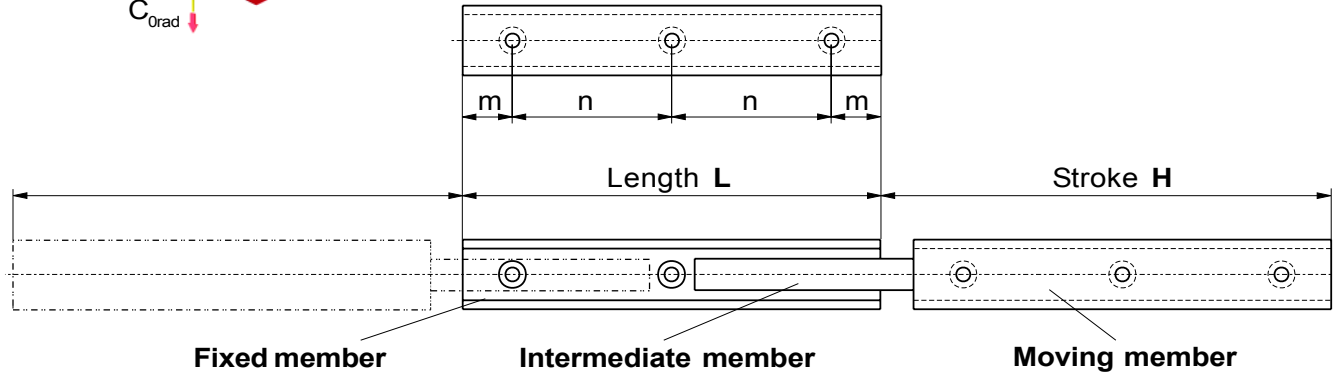

Order code	Stroke H [mm]	Fixed and moving member				C _{Orad} [N]
		L [mm]	m [mm]	n [mm]	No. holes	
DBN22-130	152	130	25	80	2	120
DBN22-210	222	210	25	80	3	282
DBN22-290	308	290	25	80	4	235
DBN22-370	392	370	25	80	5	185
DBN22-450	462	450	25	80	6	162
DBN22-530	548	530	25	80	7	136
DBN22-610	632	610	25	80	8	117
DBN22-690	702	690	25	80	9	108
DBN22-770	788	770	25	80	10	95

Note: Load C_{Orad} is intended for single telescopic rail

Order code	Stroke H [mm]	Fixed and moving member				C _{Orad} [N]
		L [mm]	m [mm]	n [mm]	No. holes	
DBN28-130	148	130	25	80	2	237
DBN28-210	232	210	25	80	3	434
DBN28-290	296	290	25	80	4	614
DBN28-370	380	370	25	80	5	482
DBN28-450	464	450	25	80	6	393
DBN28-530	548	530	25	80	7	332
DBN28-610	630	610	25	80	8	289
DBN28-690	714	690	25	80	9	255
DBN28-770	798	770	25	80	10	227
DBN28-850	864	850	25	80	11	214
DBN28-930	950	930	25	80	12	194
DBN28-1010	1034	1010	25	80	13	178
DBN28-1170	1202	1170	25	80	15	152

Note: Load C_{Orad} is intended for single telescopic rail

Order code	Stroke H [mm]	Fixed and moving member				C _{Orad} [N]
		L [mm]	m [mm]	n [mm]	No. holes	
DBN35-210	254	210	25	80	3	399
DBN35-290	318	290	25	80	4	667
DBN35-370	406	370	25	80	5	522
DBN35-450	494	450	25	80	6	429
DBN35-530	558	530	25	80	7	394
DBN35-610	646	610	25	80	8	338
DBN35-690	734	690	25	80	9	297
DBN35-770	798	770	25	80	10	279
DBN35-850	886	850	25	80	11	250
DBN35-930	974	930	25	80	12	227
DBN35-1010	1038	1010	25	80	13	216
DBN35-1170	1214	1170	25	80	15	183
DBN35-1330	1366	1330	25	80	17	165
DBN35-1490	1518	1490	25	80	19	149

Note: Load C_{Orad} is intended for single telescopic rail

Order code	Stroke H [mm]	Fixed and moving member				C _{Orad} [N]
		L [mm]	m [mm]	n [mm]	No. holes	
DBN43-210	246	210	25	80	3	613
DBN43-290	316	290	25	80	4	1125
DBN43-370	416	370	25	80	5	1310
DBN43-450	486	450	25	80	6	1331
DBN43-530	556	530	25	80	7	1193
DBN43-610	626	610	25	80	8	1082
DBN43-690	726	690	25	80	9	912
DBN43-770	796	770	25	80	10	845
DBN43-850	866	850	25	80	11	788
DBN43-930	966	930	25	80	12	693
DBN43-1010	1036	1010	25	80	13	654
DBN43-1170	1206	1170	25	80	15	559
DBN43-1330	1376	1330	25	80	17	488
DBN43-1490	1516	1490	25	80	19	450
DBN43-1650	1686	1650	25	80	21	403
DBN43-1810	1856	1810	25	80	23	365
DBN43-1970	2026	1970	25	80	25	334

Note: Load C_{Orad} is intended for single telescopic rail

LTF44 SERIES

This slide is formed by a fixed member, an identical moving member and an **S-shaped intermediate member**. Built from cold-drawn carbon-steel, this compact slide with non-hardened raceways offers an excellent solution where space is limited. The **LTF44** is perfect for applications without continuous repeated movements (In cases of continuous movements, we recommend slides with hardened raceways like the DS, DE, and DBN series). The S-shaped intermediate member transmits the load from the moving element to the fixed through a double row of ball bearings. This design allows low deflection even when the slide is completely open.

The fixed (top) member must be mounted to the fixed structure and the moving member to the mobile structure using all of the threaded holes.

Both members must be mounted to a plane and rigid structure since they will assume the same rigidity and planarity as the mounting surface.

Although the slides have pins strong enough to stop the ballcage and to return the intermediate member, they are not designed to stop a moving member carrying a load.

External endstops must be added for this purpose.

Scale 1:1

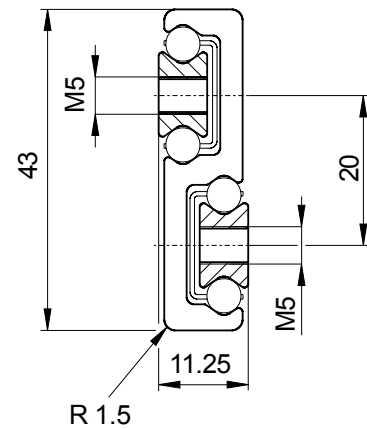

Weight LTF44: 2.7 kg/m

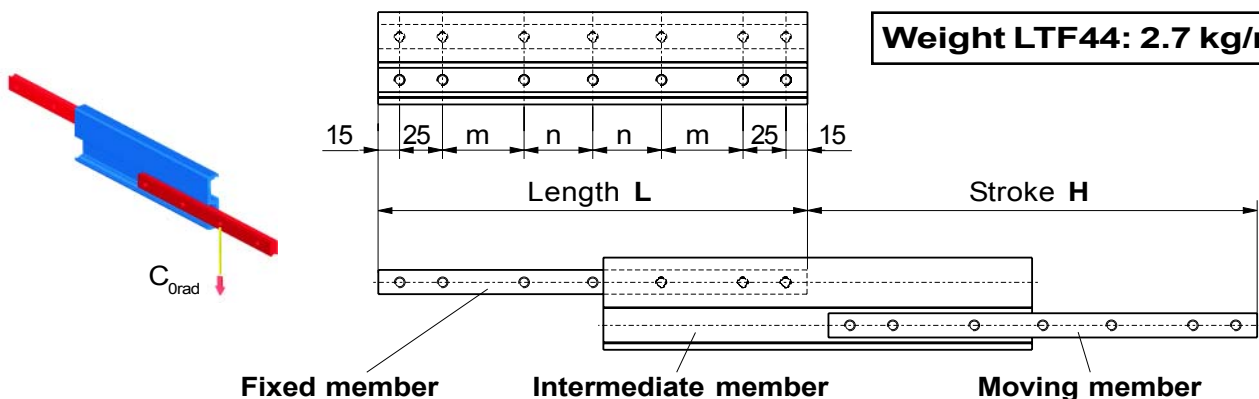

Order code	Stroke H [mm]	Fixed and moving member				C _{Orad} [N]
		L [mm]	m [mm]	n [mm]	No. holes	
LTF44-200	210	200	60	0	5	114
LTF44-225	235	225	72.5	0	5	130
LTF44-250	260	250	85	0	5	144
LTF44-275	285	275	97.5	0	5	162
LTF44-300	310	300	110	0	5	180
LTF44-325	335	325	122.5	0	5	196
LTF44-350	360	350	135	0	5	210
LTF44-375	385	375	147.5	0	5	226
LTF44-400	410	400	160	0	5	246
LTF44-425	435	425	172.5	0	5	262
LTF44-450	460	450	185	0	5	276

Note: Load C_{Orad} is intended for single telescopic rail

Order code	Stroke H [mm]	Fixed and moving member				C _{Orad} [N]
		L [mm]	m [mm]	n [mm]	No. holes	
LTF44-500	510	500	100	110	7	312
LTF44-550	560	550	100	135	7	342
LTF44-600	610	600	100	160	7	384
LTF44-650	660	650	100	185	7	408
LTF44-700	710	700	150	160	7	444
LTF44-750	760	750	150	185	7	474
LTF44-800	810	800	150	210	7	510
LTF44-850	860	850	150	235	7	540
LTF44-900	910	900	150	260	7	576
LTF44-950	960	950	150	285	7	612
LTF44-1000	1010	1000	150	310	7	648

Note: Load C_{Orad} is intended for single telescopic rail

Order code:

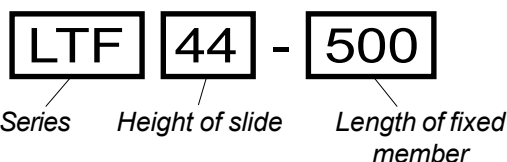

ASN SERIES

This slide is formed by a fixed member and a differently shaped moving member of the same length. Both members have hardened raceways.

This thin slide offers semi-telescopic movement. **The stroke H is reached when the moving member extends over half its length out one side of the fixed member.** By removing the end stop screw at the end of the fixed member, a **double direction stroke** equal to 2H (slightly longer than the closed rail length) can be reached. (Removal of this screw will not cause the slide to disassemble). This means that the moving member will move more than half its length out one side of the rail and more than half its length out the other.

ASN series slides can be used in both horizontal and vertical applications. For more information, please consult our application engineering department.

Although the slides have pins strong enough to stop the ballcage and to return the intermediate member, they are not designed to stop a moving member carrying a load.

External endstops must be added for this purpose.

Upon request, slides with special length strokes can be ordered. Special strokes can be up to 65% of the closed length of the slide while still maintaining high load capacities and low deflection. For more information, please contact our engineering department.

Order codes are listed on page C21.

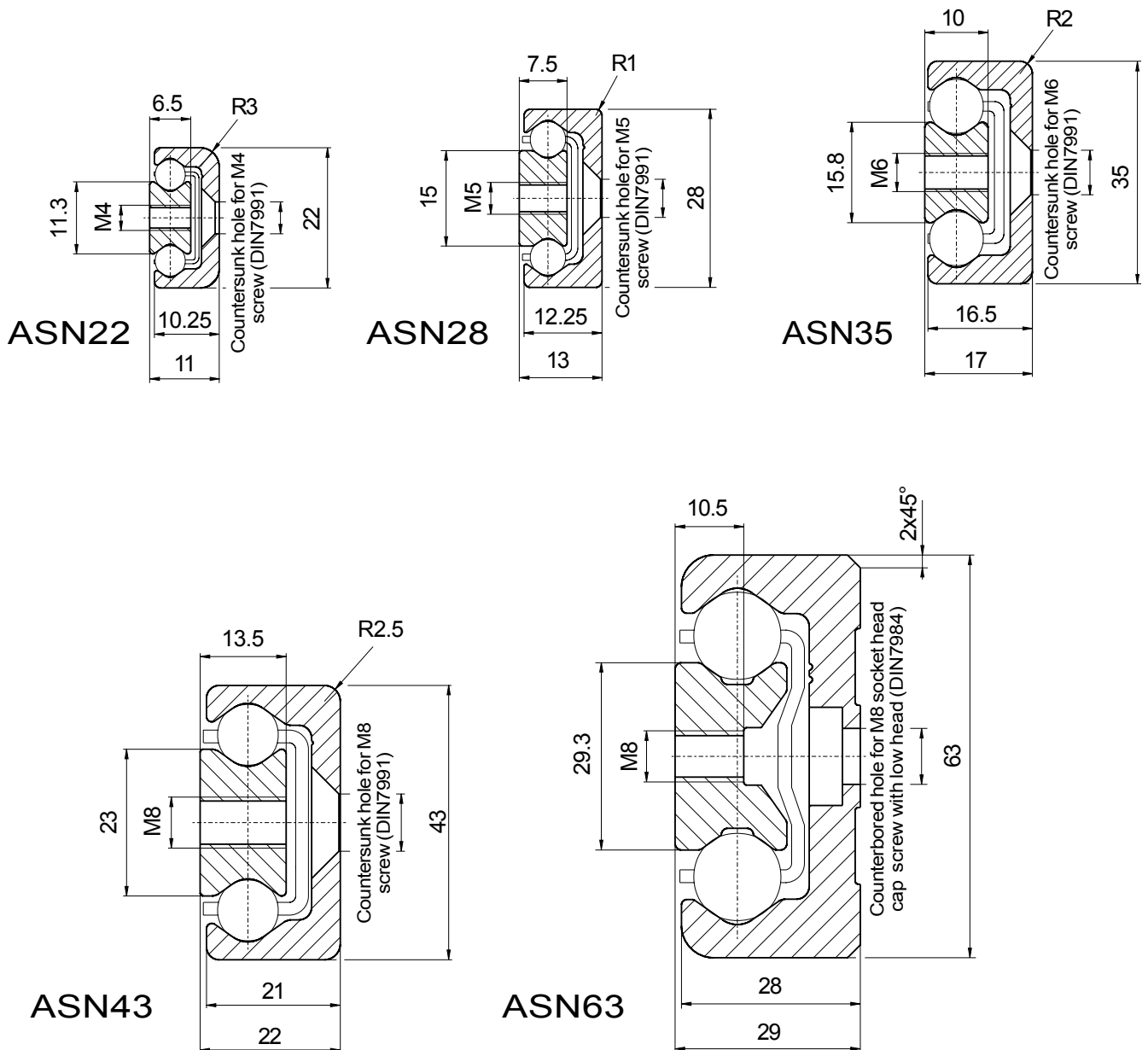

Scale 1:1

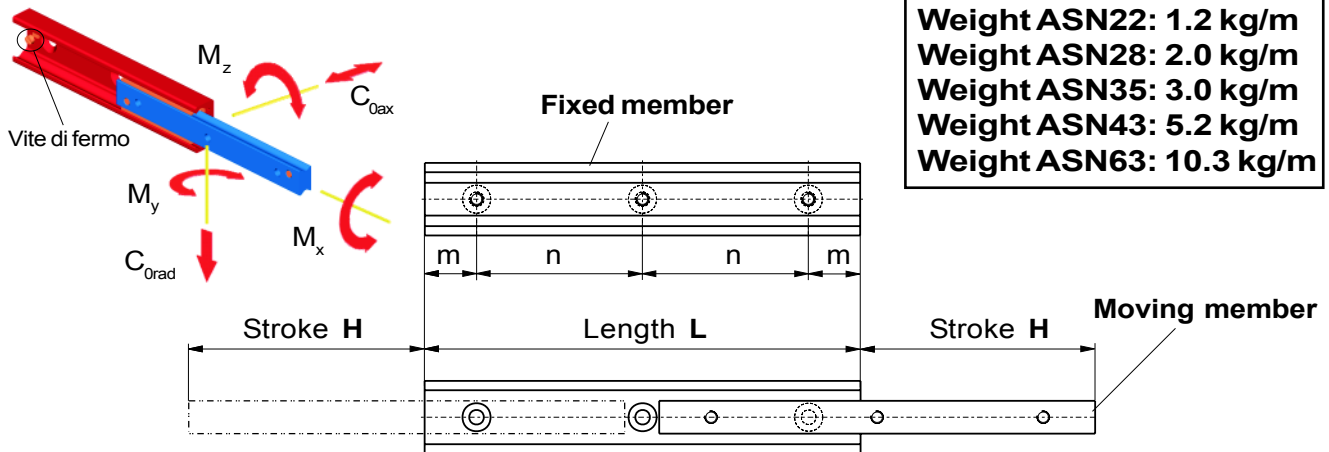

Note: Subsequently all the load capacities are intended for single rail:

Type	Stroke H [mm]	Fixed and moving member				C _{Orad} [N]	C _{Oax} [N]	M _x [Nm]	M _y [Nm]	M _z [Nm]
		L [mm]	m [mm]	n [mm]	No. holes					
ASN22-130	76	130	25	80	2	322	225	10	10	15
ASN22-210	111	210	25	80	3	728	510	19	36	51
ASN22-290	154	290	25	80	4	1004	703	26	69	99
ASN22-370	196	370	25	80	5	1291	903	34	113	162
ASN22-450	231	450	25	80	6	1715	1200	43	180	258
ASN22-530	274	530	25	80	7	1990	1393	50	248	355
ASN22-610	316	610	25	80	8	2276	1593	57	327	467
ASN22-690	351	690	25	80	9	2704	1893	66	436	623
ASN22-770	394	770	25	80	10	2978	2085	73	539	769

Type	Stroke H [mm]	Fixed and moving member				C _{Orad} [N]	C _{Oax} [N]	M _x [Nm]	M _y [Nm]	M _z [Nm]
		L [mm]	m [mm]	n [mm]	No. holes					
ASN28-130	74	130	25	80	2	626	438	25	20	28
ASN28-210	116	210	25	80	3	1131	792	42	57	82
ASN28-290	148	290	25	80	4	1960	1372	64	132	188
ASN28-370	190	370	25	80	5	2469	1729	81	213	305
ASN28-450	232	450	25	80	6	2980	2086	99	314	449
ASN28-530	274	530	25	80	7	3490	2443	116	435	621
ASN28-610	315	610	25	80	8	4020	2814	134	575	821
ASN28-690	357	690	25	80	9	4530	3171	151	735	1050
ASN28-770	399	770	25	80	10	5041	3528	169	914	1306
ASN28-850	432	850	25	80	11	5869	4108	190	1165	1665
ASN28-930	475	930	25	80	12	6358	4451	208	1389	1984
ASN28-1010	517	1010	25	80	13	6868	4807	225	1613	2330
ASN28-1170	601	1170	25	80	15	7888	5521	260	2175	3108

Type	Stroke H [mm]	Fixed and moving member				C _{Orad} [N]	C _{Oax} [N]	M _x [Nm]	M _y [Nm]	M _z [Nm]
		L [mm]	m [mm]	n [mm]	No. holes					
ASN35-210	127	210	25	80	3	1065	745	57	57	81
ASN35-290	159	290	25	80	4	2052	1437	91	144	205
ASN35-370	203	370	25	80	5	2623	1836	116	235	336
ASN35-450	247	450	25	80	6	3194	2236	141	349	498
ASN35-530	279	530	25	80	7	4248	2974	175	535	765
ASN35-610	323	610	25	80	8	4816	3371	200	701	1002
ASN35-690	367	690	25	80	9	5385	3769	225	890	1271
ASN35-770	399	770	25	80	10	6459	4521	259	1176	1679
ASN35-850	443	850	25	80	11	7024	4917	284	1416	2023
ASN35-930	487	930	25	80	12	7591	5313	310	1679	2399
ASN35-1010	519	1010	25	80	13	8674	6072	343	2064	2949
ASN35-1170	607	1170	25	80	15	9802	6861	394	2717	3882
ASN35-1330	683	1330	25	80	17	11453	8017	453	3592	5131
ASN35-1490	759	1490	25	80	19	13109	9176	512	4588	6554

Type	Stroke H [mm]	Fixed and moving member				C _{0rad} [N]	C _{0ax} [N]	M _x [Nm]	M _y [Nm]	M _z [Nm]
		L [mm]	m [mm]	n [mm]	No. holes					
ASN43-210	123	210	25	80	3	1650	1155	107	84	120
ASN43-290	158	290	25	80	4	2945	2062	165	201	288
ASN43-370	208	370	25	80	5	3443	2410	204	308	440
ASN43-450	243	450	25	80	6	4766	3336	263	509	728
ASN43-530	278	530	25	80	7	6124	4287	321	762	1088
ASN43-610	313	610	25	80	8	7503	5252	379	1064	1521
ASN43-690	363	690	25	80	9	7947	5563	418	1294	1849
ASN43-770	398	770	25	80	10	8922	6245	457	1547	2210
ASN43-850	433	850	25	80	11	10308	7216	516	1967	2811
ASN43-930	483	930	25	80	12	11143	7800	574	2439	3484
ASN43-1010	518	1010	25	80	13	12526	8768	633	2961	4230
ASN43-1170	603	1170	25	80	15	14344	10041	730	3943	5633
ASN43-1330	688	1330	25	80	17	16164	11315	828	5065	7236
ASN43-1490	758	1490	25	80	19	18538	12977	925	6328	9041
ASN43-1650	843	1650	25	80	21	20755	14528	1042	8029	11470
ASN43-1810	928	1810	25	80	23	22572	15800	1140	9601	13716
ASN43-1970	1013	1970	25	80	25	24390	17073	1237	11314	16162

Type	Stroke H [mm]	Fixed and moving member				C _{0rad} [N]	C _{0ax} [N]	M _x [Nm]	M _y [Nm]	M _z [Nm]
		L [mm]	m [mm]	n [mm]	No. holes					
ASN63-610	333	610	25	80	8	11094	7766	856	1553	2219
ASN63-690	373	690	25	80	9	13059	9142	989	2072	2960
ASN63-770	413	770	25	80	10	15032	10522	1121	2666	3808
ASN63-850	453	850	25	80	11	17010	11907	1254	3334	4763
ASN63-930	493	930	25	80	12	19632	13742	1387	4077	5824
ASN63-1010	533	1010	25	80	13	21625	15138	1520	4894	6992
ASN63-1170	613	1170	25	80	15	24952	17466	1785	6754	9648
ASN63-1330	693	1330	25	80	17	28934	20254	2051	8912	12731
ASN63-1490	773	1490	25	80	19	32919	23043	2316	11368	16240
ASN63-1650	853	1650	25	80	21	36908	25835	2581	14123	20176
ASN63-1810	933	1810	25	80	23	40898	28629	2847	17177	24539
ASN63-1970	1013	1970	25	80	25	44890	31423	3112	20530	29328

Order code:

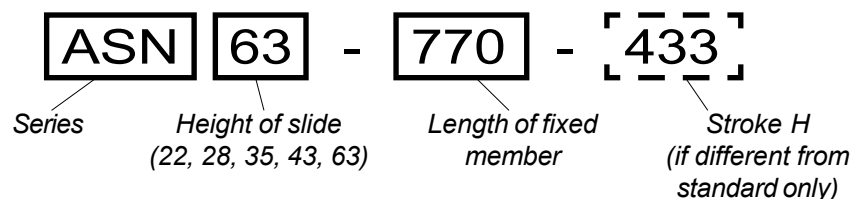

Note: For special versions, the stroke H can only vary from the standard values listed on these pages, by a multiple of the following values:

- ASN22...: 7.5 mm (Example: ASN22-290-161)*
- ASN28...: 9.5 mm (Example: ASN28-370-199)*
- ASN35...: 12 mm (Example: ASN35-530-291)
- ASN43...: 15 mm (Example: ASN43-690-378)
- ASN63...: 20 mm (Example: ASN63-930-503)

* Round all strokes down to the nearest whole number.

DMS63 SERIES

TELESCOPIC RAILS WITH HIGHEST CAPACITY LOAD

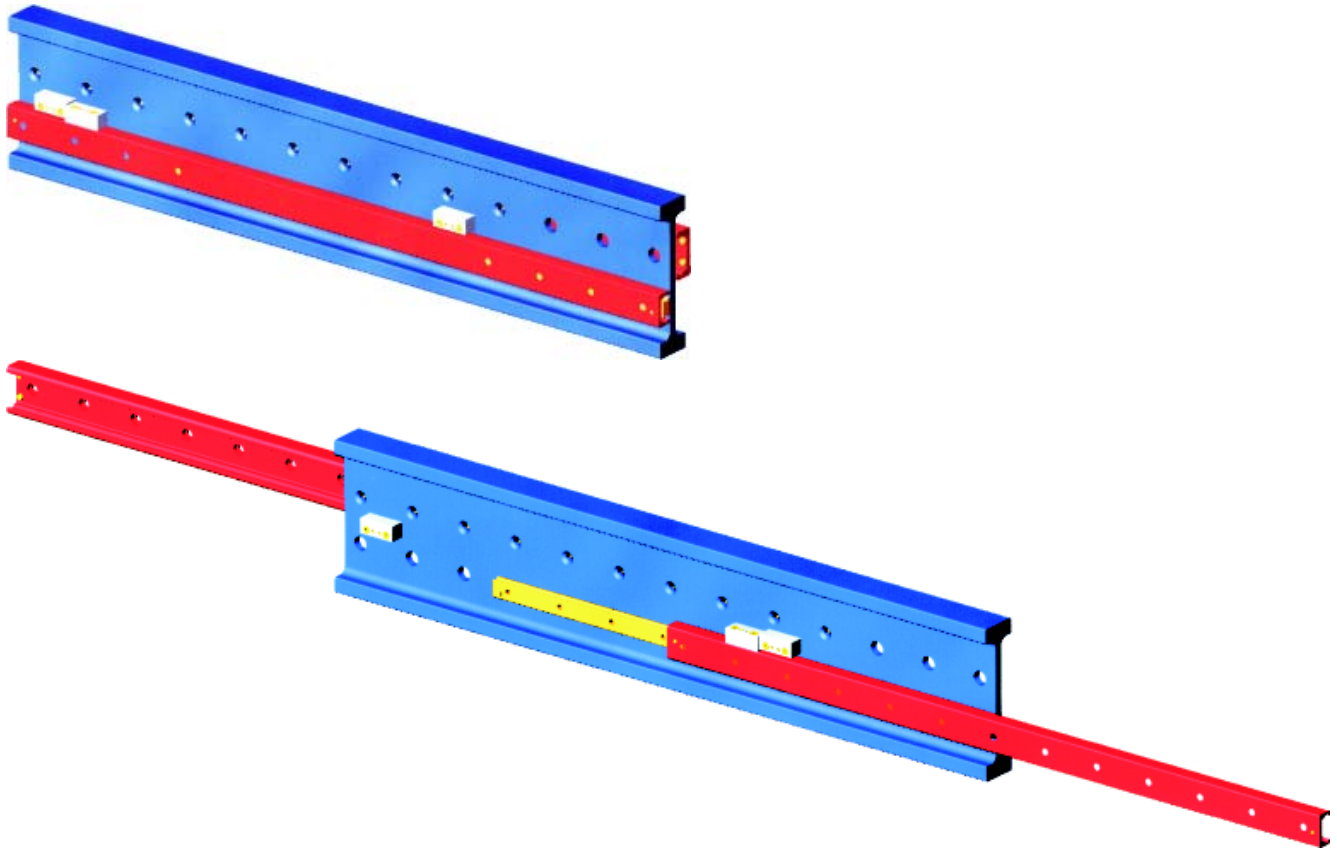

With **DMS63 TELESCOPIC RAIL** series, **ROLLON** introduces a new linear solution to move very heavy structures maintaining high stiffness.

The strength of the system is guaranteed by **63 mm** and **43 mm** section rails and by **I-beam intermediate element**.

It can support extremely heavy loads with constant movements (24 hrs a day, 7 days a week) even with vibrations and high stroke frequencies.

On request we can provide rails with double direction stroke.

Superficial treatments available are **electrolytic zinc plating** (with ISO 2081 standards) or, if the working environment requires stronger protection, **chemical nickel plating**.

Application fields:

- Railways (train battery extraction)
- Naval constructions
- Civilian/military mobile units
- Mobile shops (exposition units)

PRODUCT SELECTION

The choice of a telescopic slide should be mainly based on the **applied load** and the **maximum acceptable deflection** in the open position. The load capacity of a telescopic slide is determined by two factors: the load capacity of the ballcage and the resistance of the intermediate member. In general, the load capacity is limited to the load applied on the ballcage for slides with short strokes; it is limited by the resistance of the intermediate member for slides with medium and long strokes.

The **load capacity** of each slide is **represented by the value C_{0rad}** as indicated in the preceding pages. This value represents the **maximum load applicable in the center of gravity of the moving member in the completely extended position**.

In the most common applications, a pair of the slides is used with the center of the load applied equidistant from the two moving members (**P₁** in fig.1). The load capacity of a pair of rails mounted like this is:

$$P_1 = 2 C_{0rad}$$

(If the center of gravity is located in another position, please contact our application engineering department).

When the load is applied perpendicular to the slide (see fig. 2), the estimated deflection of the single telescopic rail in the open position under a load is the following:

$$f = P [mm] \quad (1)$$

where:

f is the amount of deflection (in mm);

q is the coefficient that depends on the nominal stroke **H** and is listed in the graph at right;

t is a coefficient that depends on the series of slide and is listed below:

DS28	t = 180	DBN22	t = 3
DS43	t = 800	DBN28	t = 8
DE22	t = 8	DBN35	t = 13
DE28	t = 17	DBN43	t = 56
DE35	t = 54	LTF44	t = 25
DE43	t = 220		

P (in newtons) is the load that is actually being applied on the moving element (which must always be less than the maximum load capacity **C_{0rad}** of the slide – see also “Verification of static load” on page C25)

Note that the above formula is valid for a single rail. When a pair of slides is used (see figure 1), **P = P₁/2**. The results of the formula shall remain valid only if the mounting structure is extremely rigid. If the mounting structure is not rigid, the deflection will be greater.

The deflection for the **ASN** series is almost completely determined by the mounting structure; actual calculation of deflection is therefore very difficult but should be very limited in any case. For more information, please contact our application engineering department.

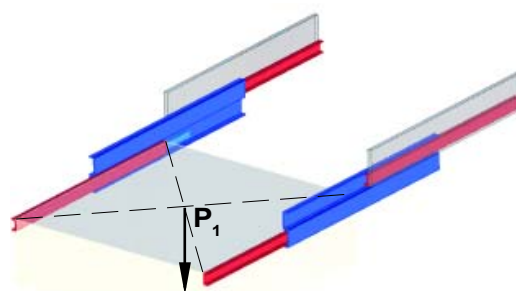

fig. 1

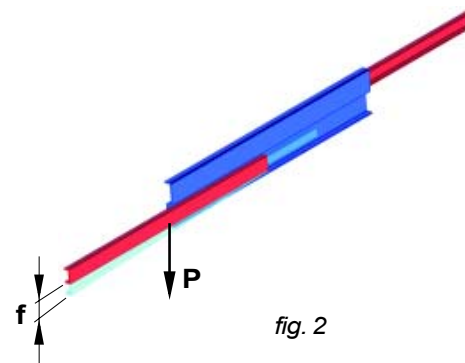
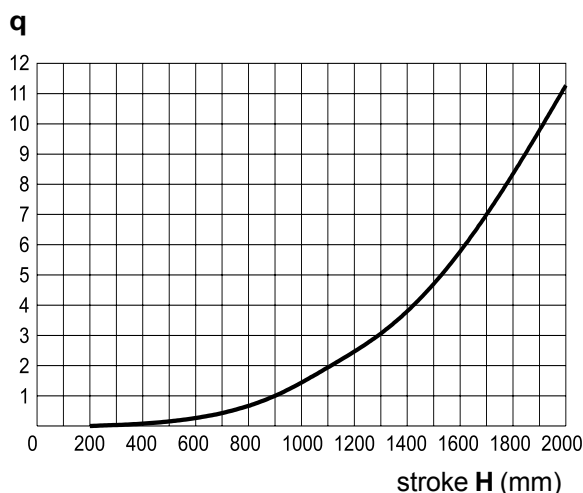

fig. 2



VERIFICATION OF STATIC LOAD

As you can see from pages C20 and C21, **ASN** slides can carry loads and moments in every direction. It is, however, always necessary to verify that the total external loads and/or moments end up being less than or equal to the maximum capacities in the respective directions divided by the coefficient of safety z . The safety factor z can vary from a minimum of 1 in applications without impacts or vibration, with low frequency and high mounting precision, to a maximum of 3.5 in applications with impacts and vibration, high frequency or speed, and low mounting precision.

$$\frac{P_{rad}}{C_{0rad}} \leq \frac{1}{z} \quad \frac{P_{ax}}{C_{0ax}} \leq \frac{1}{z} \quad \frac{M_1}{M_x} \leq \frac{1}{z} \quad \frac{M_2}{M_y} \leq \frac{1}{z} \quad \frac{M_3}{M_z} \leq \frac{1}{z}$$

The formula mentioned above is valid if the external load consists of only one force or moment. In applications where more than one force or moment acts on the slides (and most applications fall into this category), it is necessary to verify that:

$$\frac{P_{rad}}{C_{0rad}} + \frac{P_{ax}}{C_{0ax}} + \frac{M_1}{M_x} + \frac{M_2}{M_y} + \frac{M_3}{M_z} \leq \frac{1}{z}$$

For all other telescopic slides (**DS, DE, DBN, LTF44**) where the load should be applied radially, the only result to verify is:

$$\frac{P_{rad}}{C_{0rad}} \leq \frac{1}{z}$$

SPEED

The limits of maximum speed are determined by the mass of the intermediate member which must be pulled by the moving member. The speed diminishes with the increasing length of the slide as indicated below.

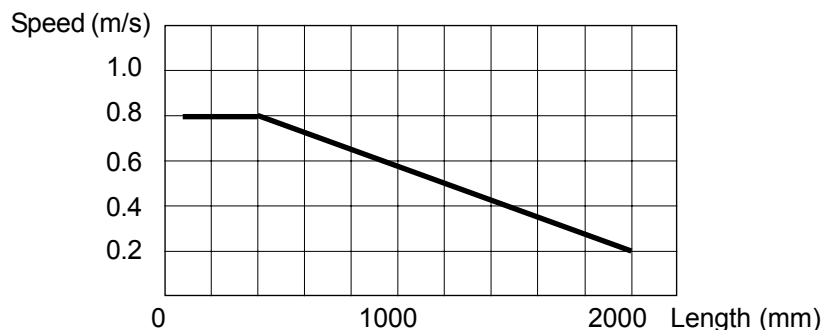

OPENING AND CLOSING FORCE

The force necessary to open or close a telescopic rail depends on the applied load and on the deflection of the members when open. From the closed position, the opening force required is determined principally by the coefficient of friction of the ball bearing. This coefficient is equal to **0.01** when mounted and lubricated correctly. During the extraction, this force decreases in function of the elastic deformation of the loaded rails. From the open position, the force needed to close will be greater than the value determined only by the coefficient of friction of the ball bearings since the elastic deformation of the slide (even if minimal) will effectively cause the moving member to climb an inclined plane.

LIFETIME

Lifetime is defined as the number of cycles of opening and closing that the telescopic rail is able to run without presenting wear that would substantially compromise its function. The lifetime of a telescopic slide is affected by many factors including applied loads, the working atmosphere, lubrication, speed, mounting, and the presence of impacts or vibrations, etc.

It is not possible to offer a formula that would take all of these important factors into consideration. It is possible to state that, based on experimental test results, in ideal conditions **with an applied load of 2/3 the C_{0rad} value, more than 500,000 working cycles can be reached.**

TECHNICAL APPLICATION SUGGESTION

All rails from the DS, DE, DBN, and LTF44 series should be applied only for horizontal movements due to the weight of the intermediate member. For DS and LTF44 series slides, the applied loads should act along the vertical axis of the slide section. For DE and DBN series, the applied loads can act along either horizontal axis. **DS and LTF44 rails must always be mounted in such a way that the moving member is always beneath the fixed member for a gravity based load** (see figure below). If mounted in the opposite manner, these slides could present problems including poor quality of movement.

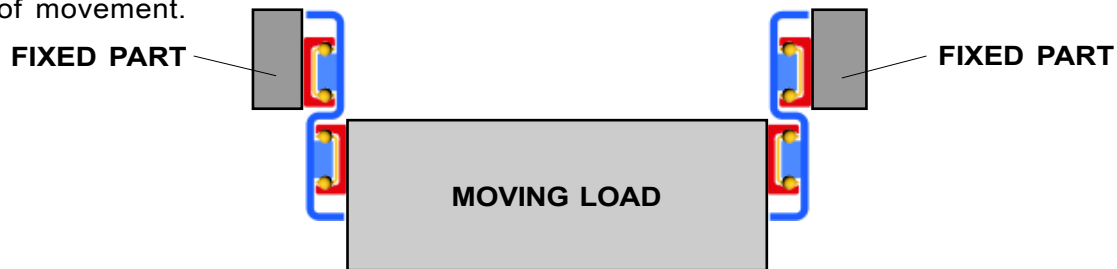

Semi-telescopic rails like the **ASN** series can be used in vertical applications as long as the applied stroke is equal to the maximum stroke of the slide and the stroke length is constant and not variable. The endstops and pins in the **ASN** rails are designed to stop the moving, unloaded slide from disassembling. External endstops must be added to properly block a moving load.

The **TELESCOPIC RAIL** slides can be used for repeated, **continuous movements as needed in automatic systems** provided that the strokes are constant and not variable for the whole work cycle. The speed of these applications must always be verified against the chart on the previous page. The movement of these slides is provided by a ballcage which, if the repeated strokes are of variable lengths, can occasionally drift from its original position. This phase displacement would cause a stiff or difficult movement and could limit the stroke length. If the application does have variable stroke lengths, the means of actuation must be dimensioned so that enough strength to “rephase” the slide is provided. Alternatively, if the stroke is variable, a full-stroke cycle must be included at regular intervals to ensure that the ballcage of the slide does not eventually drift.

To provide the best functionality and lifetime relative to the applied load, smoothness of movement, and rigidity, **it is important that the slides be mounted using all of the mounting holes to a rigid, plane structure**. If two rails are used it is important that they are mounted on parallel surfaces. The fixed and moving members will assume the rigidity of the mounting structure. The intermediate element is a structural member.

Although the slides have pins that stop the movement when not loaded, the pins are not designed to stop a moving loaded slide. External endstops should be used to stop the movements. (While the endstops on the DS slides will stop a slide propelled manually, adding external endstops will certainly be beneficial). Please consult our application engineering department for more information.

TEMPERATURE

The slides from the **DE, DBN, LTF44, and ASN** series can be used in atmospheres with temperatures reaching +170°C (+338°F) (over 130°C [266°F] it is necessary to use a high temperature grease). Slides of the **DS** series have rubber endstops which allow them to be used in temperatures ranging from -30°C (-22°F) to +110°C (+230°F).

ANTICORROSIVE PROTECTION

All of the **TELESCOPIC RAILS** are protected with **electrolytic zinc coating as per ISO2081**. If the atmosphere requires stronger protection, it is possible to supply the slides with chemical nickel coating and stainless steel ball bearings.

LUBRICATION

In normal working conditions, it is recommended to lubricate the slides at least **every 50,000 cycles** although this depends heavily upon the actual conditions and atmosphere of the application. For critical working conditions, the slides must be lubricated more often. Before lubricating, the raceways must be cleaned free of any dirt and debris. With the slide in the open position, distribute a sufficient quantity of **lithium-based, medium consistency grease** on the races and then in the spaces between the ball bearings.