

EPT Mounted Bearing Technical Support

Browning Technical Services

Phone: 606-564-2093

FAX: 606-564-2079

Mounted Bearing Application Engineering

Phone: 219-465-2211

FAX: 219-465-2290

E-mail: browningbearing.eng@Emerson-EPT.com

APPLICATION CONSIDERATIONS

The proper selection and application of power transmission products and components, including the related area of product safety, is the responsibility of the customer. Operating and performance requirements and potential associated issues will vary appreciably depending upon the use and application of such products and components. The scope of the technical and application information included in this publication is necessarily limited. Unusual operating environments and conditions, lubrication requirements, loading supports, and other factors can materially affect the application and operating results of the products and components and the customer should carefully review its requirements. Any technical advice or review furnished by Emerson Power Transmission Corporation and its divisions with respect to the use of products and components is given in good faith and without charge, and Emerson assumes no obligation or liability for the advice given, or results obtained, all such advice and review being given and accepted at customer's risk.

For a copy of our Standard Terms and Conditions of Sale, Disclaimers of Warranty, Limitation of Liability and Remedy, please contact Emerson Power Transmission Customer Service at 1-800-626-2120. These terms and conditions of sale, disclaimers and limitations of liability apply to any person who may buy, acquire or use an Emerson Power Transmission Corporation product referred to herein, including any person who buys from a licensed distributor of these branded products.



Browning[®] Engineering

Application Considerations	262
Selection/Life Calculations	
Ball Bearings	266
Tapered Roller Bearings	268
Spherical Roller Bearings	269
Load Capacity/Life Tables	
Ball Bearings – 100 Series	270
Ball Bearings – 200 & 300 Series	271
Tapered Roller Bearings – 900 & 950 Series	272
Tapered Roller Bearings – 920 & 970 Series	273
Spherical Roller Bearings – 1000 & 1100 Series	274
Spherical Roller Bearings – 22200 & 22500	275
General Engineering	276
Sample Calculations	278
Installation Instructions	
Set Screw Lock	280
BOA Concentric	281
Eccentric Lock	282
Insert Replacement Ball Bearings	286
950/970 Tapered Roller Bearings	287
Lubrication	
Ball Bearings	288
Tapered Roller Bearings	289
Spherical Roller Bearings	290
Fittings	291
Vibration Analysis	
Ball Bearings	292
Tapered Roller Bearings – 900 & 950 Series	295
Tapered Roller Bearings – 920 & 970 Series	296
Spherical Roller Bearings – 1000 & 1100 Series	297
Spherical Roller Bearings – 22200 & 22500	298

Application Considerations



Application Consideration	Mounted Bearing Recommendation	Reference	Starting Page
Vibration	Where vibration is a concern typified by fan and blower applications BOA Concentric Ball Bearings can be used. The concentric lock keeps the shaft centered in the bearing, maintains ball path roundness, and reduces bearing induced vibration. Rubber Mounted inserts and pillow blocks are available for shock absorption.	Mounted Ball Information BOA Concentric Information Rubber Mount Information Vibration Analysis	52 89, 95 293
Reversing	Eccentric Locking should be avoided on reversing applications. This lock may be loosened where frequent and quick reversing takes place. Set screw, BOA Concentric, tapered adapter or press fit locking is recommended.	Mounted Ball Information Set Screw Lock BOA Concentric Spherical Roller Information 1000/1100 22200/22500 Tapered Roller Information E920 970	4 52 126 140 102 116
Thin Mounting Surface	When applying mounted ball bearings to thin framework solid base housings avoid frame bending. Controlled loose fit between insert and housing in the "AH" ball bearing provides misalignment resulting in less chance of frame flexing. Identify stock Air Handling units by noting the (AH) symbol next to the housing size on dimension pages. Other sizes may be available depending on quantities and lead time requirements.	Ball Bearing Information Set Screw Lock BOA Concentric "AH" Ball Bearing Information	4 52 50
Tight Space Constraint	Tapped Base pillow block housings provide reduced dimensions with mounting through the base where space is at a premium. Two bolt flanges are convenient for side mounting in space restricted areas.	Tapped Base Information Set Screw Lock (200) BOA Concentric (200) Eccentric Lock (100) Two Bolt Flange Information Set Screw Lock (200) Set Screw Lock (300) Set Screw Lock (100) BOA Concentric (200) BOA Concentric (300) Eccentric Lock (200) Eccentric Lock (100)	13 58 84 8 21 30 56 65 74 82
Specialty Shafting	When expensive shafting such as hardened or stainless steel is used Tapered Adapter and BOA Concentric bearings will provide more reliable locking and eliminate shaft marring caused by Set Screw and Eccentric lock bearings.	BOA Concentric Information Tapered Adapter Information	52 140
Frequent Bearing Removal	Eccentric Lock and BOA Concentric bearings provide easy removal from the shaft on applications that require frequent bearing adjustment or relocation on the shaft.	BOA Concentric Information Eccentric Lock Ball Bearings Eccentric Lock Tapered 900 950	52 70 112 116

Application Consideration	Mounted Bearing Recommendation	Reference	Starting Page
High Speed	Consider Ball Bearings. Point contact between balls and bearing race has low friction. Maximum speed capacity varies by bore size. Concentric locking as available with BOA Concentric is best for very high speeds.	Mounted Ball Information Load / Speed Ratings BOA Concentric Information	270 52
High Load	Roller Bearings have higher load capacity than ball bearings. Spherical Rollers handle higher speeds than Tapered Rollers where combinations of higher speed and higher load exist.	Load / Speed Ratings Spherical Roller Information 1000/1100 22200/22500 Tapered Roller Information 900/950 920/970	272 274 275 272 273
Thrust Load	Tapered Roller Bearing can handle higher thrust and combination loads. Spherical Bearings and Ball Bearings can handle limited thrust. An engineering review is recommended where thrust and high speed exist.	Load / Speed Ratings Tapered Roller Information 900/950 920/970	272 272 273
Shock Load	Ductile and Cast Steel Housings can be used in heavy shock environments.	Ductile Tapered Roller Bearings Ductile Spherical Roller Bearings Cast Steel Spherical Roller Bearings	116 127 144, 146
Static Misalignment	950 and 970 Tapered Roller Bearings and all Housed Mounted Ball Bearings are externally self aligning (the bearing insert can misalign with respect to the housing.) These bearings are well suited for applications with static misalignment. Misalignment limits should be considered for each specific bearing type relative to application needs.	Ball Bearing Information Set Screw Lock BOA Concentric Eccentric Lock Tapered Roller Information 950/970	4 52 70 116
Dynamic Misalignment	All Spherical Roller Bearings are internally self aligning (the rollers can misalign with respect to the bearing races.) This design permits dynamic misalignment. Misalignment limits should be considered for each specific bearing type relative to application needs.	Spherical Bearing Information 1000/1100 22200/22500	126 140
Vertical Shaft	Set Screw locking is generally recommended on vertical shaft applications. Considerations should be made to account for thrust loads typical on vertical shafts. Other locking types can be used if proper support is provided. Four Bolt Flanges and Flange Cartridges provide good bearing support for vertical shafts.	Mounted Ball Information Set Screw Lock Spherical Roller Information 1000/1100 Tapered Roller Information 920 970	4 126 104 116
Noise	Where bearing noise is an issue, Ball bearings with an "AH" suffix can be used. The "AH" suffix specifies bearings with a special housing fit and 100% noise testing. Identify stock Air Handling units by noting the (AH) symbol next to the housing size on dimension pages. Other sizes may be available depending on quantities and lead time requirements.	AH Ball Bearing Information	50

Application Considerations



Application Consideration	Mounted Bearing Recommendation	Reference	Starting Page
Adjustable Shaft Centers	Applications requiring adjustment of shaft centers necessary for belt tensioning may require take up bearings and frames. The housings are slotted and can travel along the frame to change the location of the belt pulleys or sheaves.	Ball Bearing Take-up Information	
		Set Screw Lock (200)	6
		Set Screw Lock (300)	20
		Set Screw Lock (100)	28
		Eccentric Lock (200)	72
		Eccentric Lock (100)	80
		Tapered Roller Take-up Information	
		900	102
		E920	102
		Spherical Roller Take-up Information	
1000	126		
Eccentric Loads	Equipment with eccentric loading may require a housing that prevents movement between the housing and the mounting surface. Piloted Flange Cartridges have a machined flange that mates with a machined opening in the equipment to maintain bearing location. For eccentric loads a technical review is recommended.	Take Up Frames for Pillow Blocks	
		Ball Bearing	15
		Spherical Roller	153
		Ball Bearing Piloted Flanges	
Rollers and Idlers	VER bearings are designed to be pressed into a conveyor pulley or idler roll. The cylindrical outside diameter presses into the mating part and location is controlled by a snap ring.	Set Screw Lock (200)	10
		Set Screw Lock (300)	23
		BOA Concentric (200)	61
		BOA Concentric (300)	67
		Roller Bearing Piloted Flanges	
		900	106
		1000	134
Bearing Life	Bearing life can be estimated using available formulas. Keep in mind that life varies by application and the formulas estimate metal fatigue under ideal conditions.	1100	138
		Life Formulas	266
Shaft Expansion	Where shaft expansion or axial movement is caused by temperature changes or frame flexing on long shafts, a bearing with expansion capabilities should be used. Use only one fixed bearing on the drive end of the shaft.	Sample Calculations	278
		Expansion Spherical Bearings	
		1000/1100	126
		22200/22500	140
		Expansion Tapered Bearings	
Bearing Installation	Bearing performance can be greatly impacted by proper installation practices. Refer to installation information included with the product or to the catalog installation instructions.	950/970	116
		Technical Information	276
		Set Screw Lock	280
Bearing Lubrication	Bearing Performance relies on proper relubrication. This includes lubricant type, relubrication frequency, and good practices.	BOA Concentric	281
		Eccentric Lock	282
		Ball Bearing Lubrication	288
		Spherical Bearing Lubrication	290
		Tapered Bearing Lubrication	289

Application Consideration	Mounted Bearing Recommendation	Reference	Starting Page
Cartridge Replacement	All Housed Mounted Ball Bearings come with a replaceable insert. While this can save money, complete units should be purchased to avoid possible housing fit and misalignment issues. 950 and 970 series tapered roller bearings with easy to replace cartridges are also available. These provide cost effective replacements and allow bearing housings to stay mounted and in alignment with equipment.	Ball Bearing Insert Replacement Tapered Roller Bearings 950/970	286 287
Corrosion	Electroless nickel plating is available as a standard option on many ball bearing sizes. Identify stock nickel plated units by noting the (NK) symbol next to the housing size on dimension pages. Other sizes may be available depending on quantities and lead time requirements.		

Selection/Life Calculations

Ball Bearings



BEARING SYMBOLS FOR LIFE CALCULATION

- C - Basic Dynamic Rating (lbs)
- C₀ - Static Rating (lbs)
- 1,000,000 Revolutions
- n - Speed (RPM)
- P - Equivalent Radial Load (lbs)
- K - Geometry Factor
- L10 - Rated Life (Hours)
- X - Radial Factor
- L_{na} - Adjusted Rated Life
- Y - Thrust Factor
- F_a - Applied Thrust Load (lbs)
- e - Geometry Ratio
- F_r - Applied Radial Load (lbs)

Ball Bearing Life Calculation

The following formula provided by the Anti Friction Bearing Manufacturers Association (ABMA) provides a method for calculating estimated fatigue life of Ball Bearings.

$$L_{10} = (C/P)^3 \times \frac{16667}{n}$$

Where:

L10 = The number of hours that 90% of a group of identical bearings under ideal conditions will operate at a specific speed and load condition before fatigue failure is expected to occur.

Additionally, the ABMA provides application factors for Ball Bearings which need to be considered to determine an adjusted Rated Life (L_{na}).

$$L_{na} = a_1 \times a_2 \times a_3 \times L_{10}$$

Where:

L_{na} = Adjusted Rated Life.

a₁ = Reliability Factor.

Adjustment factor applied where estimated fatigue life is based on reliability other than 90% (See Table No 1).

Table 1 Life Adjustment Factor for Reliability

RELIABILITY %	L _{na}	a ₁
90	L10	1
95	L5	0.62
96	L4	0.53
97	L3	0.44
98	L2	0.33
99	L1	0.21
50	L50	5

a₂ = Material Factor

Life adjustment for Bearing race material. All Browning Ball bearing races are manufactured from 52100 Vacuum Degassed Bearing steel. Therefore the a₂ factor is 1.0 for all Browning Ball Bearings. It is important to check with all manufacturers to ensure that proper adjustments are made when other bearing steels are used.

a₃ = Life Adjustment Factor for Operating Conditions

This factor should take into account the adequacy of lubricant, presence of foreign matter, conditions causing changes in material properties, and unusual loading or mounting conditions. Assuming a properly selected bearing having adequate seals and lubricant operating below 200°F and tight fitted to the shaft, the a₃ factor should be 1.0. Mounted ball bearings are typically "slip fitted" to the shaft and rely on design features such as the inner race length and locking device for support. ABMA recommends an a₃ factor of .456 for "slip fit" ball bearings.*

Shock and Vibration—Vibration and shock loading can act as an additional loading to the steady expected applied load. When shock or vibration is present, the following a₃ Life Adjustment Factors are recommended. The shock factor is used in combination with the "slip fit" factor.

Table 2 Shock/Vibration Factor

Steady Loading	1.0
Light Shock/Vibration	.5
Moderate Shock/Vibration	.3

The a₃ factor takes into account a wide range of application and mounting conditions as well as bearing features and design. Accurate determination of this factor is normally achieved through testing and in-field experience. Consult EPT Mounted Bearing Tech Support for more information.

*See sample calculations on page 298.

Selection

Select an initial bearing size and calculate the expected L_{na} life. If the life is not acceptable, select another bearing size as appropriate and recalculate the L_{na} life. Continue this iterative process until an appropriate L_{na} life is obtained.

Combined Load Calculation

For applications where combined radial and thrust loads are present the equivalent radial load (P) must be calculated before applying L10 life formula.

- For applications with only a radial load present $P = F_r$
Where F_r = Applied radial load in pounds.

-For applications with only a thrust load present
EPT Mounted Bearing Tech Support.

Calculate (P) equivalent radial Load.

1. Use Table 3 to identify the relative axial load factor (ND2).
2. Determine the relative axial load (RAL):

$$RAL = \frac{F_a}{ND_2} \text{ -applied thrust load}$$

ND₂ -relative axial load factor

3. Match the nearest relative axial load value in Table #3 to the corresponding "e" value. for precise calculation, linearly interpolate the values for "e" for your exact relative axial load value.
4. Calculate F_a/F_r and compare value to the "e" value found in step #3 above.
5. Choose values for "X" and "Y" based on step #3 & 4 and from Table No. 3. Linear interpolation is recommended for exact calculations.
6. Calculate equivalent radial load using the following equation:
 $P = XF_r + YF_a$
7. Calculate the adjusted life (L_{na}) using the life calculation formula above.

Refer to Page 304 for Relevant Disclaimer.

For Inserts not shown in table 4:

Insert: VE-200 VS-100
VB-200 VE-100
VER-200 LS-100
SLS-100 LE-100
SLE-100 RUBRE-100
LR-100 RUBRS-100
LRS-100

Ratings: Use standard duty, 200 Series, ratings and factors for respective bore size.
Select 200 Series for highest reliability.

Insert: VS-300
VB-300

Ratings: Use medium duty, 300 Series, ratings and factors for respective bore size.

Contact EPT Mounted Bearing Tech Support at 219-465-2211 for additional details.

Table 3 Equivalent Load Calculation Data Ball Bearings

Relative Axial Load	e	Fa/Fr <= e		Fa/Fr > e	
		X	Y	X	Y
		24.92	0.19	1	0
50.03	0.22	1	0	0.56	1.99
99.91	0.26	1	0	0.56	1.71
149.35	0.28	1	0	0.56	1.55
200.10	0.30	1	0	0.56	1.45
300.15	0.34	1	0	0.56	1.31
500.25	0.38	1	0	0.56	1.15
749.65	0.42	1	0	0.56	1.04
999.05	0.44	1	0	0.56	1.00

New Applications:

Using variations of the life formulas and application information, it is possible to select bearings based on desired life, load applied, and shaft speed. **This method can be applied where axial load is less than or equal to 1/2 the radial load.**

- Determine required application hours (L_{na}).
- Calculate L_{10} using adjustment factors:

$$L_{10} = \frac{L_{na}}{a_1 \times a_2 \times a_3}$$

- Calculate Basic Dynamic Radial Rating (C_{req}).

$$C_{req} = \left(\frac{L_{10} (N)}{16667} \right)^{1/3} P$$

- Use Table 4, find a basic Dynamic Radial Rating Value greater than or equal to C_{req} calculated in step #3.
- Select any bearing from the row in step #4 or larger. If C_{req} is greater than the largest Basic Dynamic Radial Rating Value of Table 4, go to a tapered or spherical Roller Bearing Selection on page 268, 269.

Table 4 Load Ratings - Ball Bearings

STANDARD DUTY		MEDIUM DUTY		BASIC DYNAMIC RADIAL RATING	STATIC RADIAL RATING	Relative Axial Load Factor ND ²	THRUST RATING
SHAFT SIZE	INSERT #	SHAFT SIZE	INSERT #				
1/2 5/8 3/4	VS-208 VS-210 VS-212			2611	1444	0.7056	740
13/16 7/8 15/16 1	VS-213 VS-214 VS-215 VS-216			2801	1651	0.7840	490
1-1/16 1-1/8 1-3/16 1-1/4	VS-217 VS-218 VS-219 VS-220S	1	VS-316	4381	2567	1.2996	1170
1-1/4 1-5/16 1-3/8 1-7/16	VS-220 VS-221 VS-222 VS-223	1-3/16	VS-319	5782	3493	1.7424	1700
1-1/2 1-9/16	VS-224 VS-225	1-7/16	VS-323	7340	4467	2.2500	2250
1-5/8 1-11/16 1-3/4	VS-226 VS-227 VS-228	1-1/2	VS-324	7901	5139	2.5000	2350
1-13/16 1-7/8 1-15/16	VS-229 VS-230 VS-231	1-11/16 1-3/4	VS-327 VS-328	7889	5216	2.5000	2350
2	VS-232S	1-15/16	VS-331				
2 2-1/8 2-3/16	VS-232 VS-234 VS-235			9752	6601	3.3160	2880
2-1/4 2-7/16	VS-236 VS-239	2-3/16	VS-335	11789	8150	3.9690	4100
2-1/2 2-11/16	VS-240 VS-243	2-7/16 2-1/2	VS-339 VS-340	13971	10063	4.7610	4500
2-15/16	VS-247	2-11/16	VS-343	14839	11224	5.2371	5200
		2-15/16	VS-347	17412	13174	6.1875	6030
		3	VS-348				
3-1/2	VS-256	3-7/16	VS-355	21566	16301	7.7440	7830
		3-15/16	VS-363	29905	23553	11.2360	11090

- See page 270-271 for load and speed capabilities.
- See General Engineering page 276.

Selection/Life Calculations

Tapered Roller Bearings



This section outlines the formula used to select bearing size or calculate expected bearing life for Browning Tapered Roller Bearings.

Tapered Roller Bearings are excellent for applications where radial and/or thrust load ratings exceed the capabilities of a ball bearing.
Note: Maximum speeds are lower for Tapered Roller Bearings than Ball Bearings and Spherical Roller Bearings.

Bearing Symbols for Tapered Life Calculations

- C = Basic Dynamic Rating (lbs.) 90,000,000 revolutions
- P = Equivalent Radial Load (lbs.)
- L10 = Rated Life (hrs.)
- Fa = Applied Thrust Load
- Fr = Applied Radial Load
- K = Geometry Factor
- n = Speed RPM
- FIR = Bearing Internal Thrust

Tapered Roller Bearing Life Calculation

Use Step 1-4 at right and follow formula.

$$L_{10} = (C/P)^{10/3} \times \frac{3000 \text{ hours} \times 500 \text{ RPM}}{n}$$

Select an initial bearing size, and calculate the expected L10 life. If the life is not acceptable, select another bearing size as appropriate and recalculate the L10. Continue this iterative process until an appropriate L10 life is obtained.

Table 5 Shock/Vibration Factor

Steady Loading	1.0
Light Shock/Vibration	.5
Moderate Shock/Vibration	.3

Multiply the theoretical life by the above factors to determine derated theoretical life.

Combined Load Calculation

For applications where combined radial and thrust loads are present the equivalent radial load (P) must be calculated before applying the L10 life formula,

For applications with only a radial load present $P = F_r$
 Where F_r = Applied radial load in pounds

For applications with only a thrust load present, Consult EPT Mounted Bearing Tech Support

Calculate (P) equivalent radial load.

1. Calculate the bearing internal thrust reaction (FIR):

$$FIR = \frac{0.6 \times F_r}{K} \quad \begin{array}{l} \text{- applied radial load} \\ \text{- factor K for 900/950 Series page 268} \\ \text{920/970 Series page 269} \end{array}$$

2. If the thrust load (F_a) is less than or equal to FIR, then calculate the equivalent radial load as follows:

$$P = (0.5 \times F_r) + (0.83 \times K \times F_a)$$

3. If the thrust load (F_a) is greater than FIR then calculate the equivalent radial load as follows:

$$P = (0.4 \times F_r) + (K \times F_a)$$

4. Calculate the expected L10 life using the single row basic dynamic load rating. For 900/950 Series page 268.
 For 920/970 Series page 269.

$$L_{10} = \left(\frac{\text{single row load rating}}{P} \right)^{10/3} \times \frac{3000 \times 500}{n}$$

1. See page 272, 273 for load and speed capabilities.
2. See General Engineering page 276.

Spherical Roller Bearings Life Calculations

This section outlines the formula used to select bearing size or calculate expected bearing life for Browning spherical roller bearings.

Spherical Roller Bearings

Spherical roller bearings are excellent for applications where radial loads exceed the capabilities of a ball bearing or the speed limits of a tapered roller bearing.

Bearing Symbols for Spherical Life Calculations

C = Basic Dynamic Rating (lbs) 1,000,000 revolutions

P = Equivalent Radial Load (lbs)

L10 = Rated Life (hrs)

Fa = Applied Thrust Load

Fr = Applied Radial Load

n = Speed RPM

X = Radial Factor

Y = Thrust Factor

e = Geometry Ratio

Spherical Roller Bearing Life Calculations

$$L_{10} = \left(\frac{C}{P}\right)^{10/3} \times \frac{16667}{n}$$

Table 6 Shock/Vibration Factor

Steady Loading	1.0
Light Shock/Vibration	.5
Moderate Shock/Vibration	.3

Multiply the theoretical life by the above factors to determine derated theoretical life.

Combined Load Calculation

1. Select an initial spherical roller type and bore size.
2. Calculate Fa/Fr and compare the value to the "e" value found in the tables 7, 8 and 9.
3. Choose values for "X" and "Y" based on Step 1 above from the appropriate table 7, 8 and 9 based on the spherical bearing type selected.
4. Calculate equivalent load using the following equation:

$$P = XFr + YFa$$

5. Calculate the expected L10 life using the life equation above.
6. Determine if the calculated L10 meets application requirements.
7. If L10 is not acceptable, select another bearing size as appropriate and recalculate the L10 life. Continue this iterative process until an acceptable L10 is obtained.

NOTE: Always use (1) fixed and (1) floating spherical roller bearing.

Table 7

1000/1100 SERIES						
x+y Values for Combined Loading Equation						
Shaft Size	C Basic Load	e	Fa/Fr <= e		Fa/Fr > e	
			X1	Y1	X2	Y2
1 1/8-1 1/2	16,600	0.28	1.0	2.4	0.67	3.6
1 11/16-1 3/4	17,300	0.26	1.0	2.6	0.67	3.9
1 15/16-2	19,000	0.24	1.0	2.8	0.67	4.2
2 3/16	22,400	0.24	1.0	2.8	0.67	4.2
2 7/16-2 1/2	33,300	0.24	1.0	2.8	0.67	4.2
2 11/16-3	35,500	0.22	1.0	3.0	0.67	4.6
3 3/16-3 1/2	56,900	0.23	1.0	2.9	0.67	4.4
3 11/16-4	69,900	0.24	1.0	2.8	0.67	4.2
4 7/16-4 1/2	91,700	0.25	1.0	2.7	0.67	4.0
4 15/16	123,000	0.26	1.0	2.6	0.67	3.9

See page 156 for trademark acknowledgments.

Table 8

22200 & 22500 SERIES - ADAPTER MOUNT							
X & Y Values for Combined Loading Equation							
Shaft Size		C Basic Load	e	Fa/Fr <= e		Fa/Fr > e	
Popular	Other			x	y	x	y
2 7/16	2 1/2	47,700	0.22	1.0	3.0	0.67	4.6
2 11/16	2 3/4	53,100	0.22	1.0	3.0	0.67	4.6
2 15/16	3	55,100	0.22	1.0	3.0	0.67	4.6
3 3/16	-	73,100	0.23	1.0	2.9	0.67	4.4
3 7/16	3 1/2	95,500	0.24	1.0	2.8	0.67	4.2
-	3 11/16						
3 15/16	4	105,000	0.25	1.0	2.7	0.67	4.0
4 3/16	-	121,000	0.25	1.0	2.7	0.67	4
4 7/16	4 1/2	142,000	0.26	1.0	2.6	0.67	3.9
4 15/16	5	160,000	0.26	1.0	2.6	0.67	3.9
5 3/16	-	191,000	0.26	1.0	2.6	0.67	3.9
5 7/16	5 1/2	225,000	0.26	1.0	2.6	0.67	3.9
5 15/16	6	252,000	0.27	1.0	2.7	0.67	3.7
6 7/16	6 1/2	265,000	0.26	1.0	2.6	0.67	3.9
6 15/16	7	250,000	0.26	1.0	2.6	0.67	3.9
7 3/16	7 1/2	328,000	0.26	1.0	2.6	0.67	3.9
7 15/16	8	396,000	0.27	1.0	2.7	0.67	3.7

Table 9

22200 SERIES - CYLINDRICAL BORE							
x+y Values for Combined Loading							
Shaft Size		C Basic Load	e	Fa/Fr <= e		Fa/Fr > e	
S2	S3			X1	Y1	X1	Y1
3 5/8	3	53,100	0.22	1.0	3.0	0.67	4.6
3 15/16	3 3/16	55,100	0.22	1.0	3.0	0.67	4.6
4 1/8	3 3/8	73,100	0.23	1.0	2.9	0.67	4.4
4 1/2	3 13/16	95,500	0.24	1.0	2.8	0.67	4.2
4 7/8	4 3/16	105,000	0.25	1.0	2.7	0.67	4
5 5/16	4 9/16	121,000	0.25	1.0	2.7	0.67	4
5 7/8	4 15/16	142,000	0.26	1.0	2.6	0.67	3.9
6 1/4	5 5/16	160,000	0.26	1.0	2.6	0.67	3.9
6 5/8	5 3/4	191,000	0.26	1.0	2.6	0.67	3.9
7	6 1/16	225,000	0.26	1.0	2.6	0.67	3.9
7 7/16	6 7/16	252,000	0.27	1.0	2.5	0.67	3.7
7 13/16	6 7/8	265,000	0.26	1.0	2.6	0.67	3.9
8 3/8	7 1/4	250,000	0.26	1.0	2.6	0.67	3.9
8 3/4	7 5/8	328,000	0.26	1.0	2.6	0.67	3.9
9 9/16	8 5/16	396,000	0.27	1.0	2.5	0.67	3.7

1. See page 269 for load and speed capabilities.
2. See General Engineering page 276.

Load Capacity/Life Tables

Ball Bearings



BALL BEARING 100 SERIES RATINGS

This chart displays 100 series ball bearing load capacity for a given L10 life, speed, and shaft size. Values in the table represent loads at ideal conditions with press fit mounting to the shaft. ABMA recommends de-rating of slip fit mounted bearings. To obtain de-rated load, divide load in table by 1.3. Values in the table represent equivalent radial loads only. For combined load determination, see **THE BEARING SELECTION SECTION**, page 266. Areas designated by “-” exceed maximum speed value.

Table 10 Match Bore Size

100 Shaft Size	L10 HOURS	REVOLUTIONS PER MINUTE															
		50	150	250	500	750	1000	1500	1750	2000	2500	3000	3500	4000	45000	5000	5500
1/2 5/8 275	5000	315	315	315	315	315	315	275	261	250	232	218	207	198	191	184	—
	10000	315	315	315	315	275	250	218	207	198	184	173	165	157	151	146	—
	250	315	315	275	218	191	173	151	144	138	128	120	114	109	105	101	—
	50000	315	275	232	184	161	146	128	121	116	108	101	96	92	89	85	—
	100000	315	218	184	146	128	116	101	96	92	85	80	76	73	70	68	—
3/4	5000	390	390	390	390	390	390	341	324	310	287	270	257	246	—	—	—
	10000	390	390	390	390	341	310	270	257	246	228	215	204	195	—	—	—
	30000	390	390	341	270	236	215	188	178	170	158	149	141	135	—	—	—
	50000	390	341	287	228	199	181	158	150	144	133	126	119	114	—	—	—
	100000	390	270	228	181	158	144	126	119	114	106	100	95	91	—	—	—
7/8 15/16 1	5000	418	418	418	418	418	418	366	347	332	308	290	276	—	—	—	—
	10000	418	418	418	418	366	332	290	279	264	245	230	219	—	—	—	—
	30000	418	418	366	290	253	230	201	191	183	170	160	152	—	—	—	—
	50000	418	366	308	245	214	194	170	161	154	143	135	128	—	—	—	—
	100000	418	290	245	194	170	154	135	128	122	114	107	102	—	—	—	—
1 1/8 1 3/16 1 1/4	5000	654	654	654	654	654	654	572	543	519	482	454	—	—	—	—	—
	10000	654	654	654	654	572	519	454	431	412	383	360	—	—	—	—	—
	30000	654	654	572	454	396	360	315	299	286	265	250	—	—	—	—	—
	50000	654	572	482	383	334	304	265	252	241	224	211	—	—	—	—	—
	100000	654	454	383	304	255	241	211	200	191	178	167	—	—	—	—	—
1 1/4 1 3/8 1 7/16	5000	864	864	864	864	864	864	755	717	686	636	—	—	—	—	—	—
	10000	864	864	864	864	755	686	599	569	544	505	—	—	—	—	—	—
	30000	864	864	755	599	523	475	415	394	377	350	—	—	—	—	—	—
	50000	864	755	636	505	441	401	350	333	318	295	—	—	—	—	—	—
	100000	864	599	505	401	350	318	278	264	253	234	—	—	—	—	—	—
1 1/2	5000	1096	1096	1096	1096	1096	1096	958	910	870	808	—	—	—	—	—	—
	10000	1096	1096	1096	1096	958	870	760	722	691	641	—	—	—	—	—	—
	30000	1096	1096	958	760	664	603	527	501	479	445	—	—	—	—	—	—
	50000	1096	958	808	641	560	509	445	422	404	375	—	—	—	—	—	—
	100000	1096	760	641	509	445	404	353	335	321	298	—	—	—	—	—	—
1 11/16 1 3/4	5000	1180	1180	1180	1180	1180	1180	1031	979	937	—	—	—	—	—	—	—
	10000	1180	1180	1180	1180	1031	937	818	777	744	—	—	—	—	—	—	—
	30000	1180	1180	1031	818	715	650	567	539	516	—	—	—	—	—	—	—
	50000	1180	1031	870	690	603	548	479	455	435	—	—	—	—	—	—	—
	100000	1180	818	690	548	479	435	380	361	345	—	—	—	—	—	—	—
1 15/16 2	5000	1178	1178	1178	1178	1178	1178	1029	978	935	—	—	—	—	—	—	—
	10000	1178	1178	1178	1178	1029	935	817	776	742	—	—	—	—	—	—	—
	30000	1178	1178	1029	817	714	649	567	538	515	—	—	—	—	—	—	—
	50000	1178	1029	868	689	602	547	478	454	434	—	—	—	—	—	—	—
	100000	1178	817	689	547	478	434	379	360	345	—	—	—	—	—	—	—
2 2 3/16	5000	1457	1457	1457	1457	1457	1457	1273	1209	—	—	—	—	—	—	—	—
	10000	1457	1457	1457	1457	1273	1156	1010	959	—	—	—	—	—	—	—	—
	30000	1457	1457	1273	1010	882	802	700	665	—	—	—	—	—	—	—	—
	50000	1457	1273	1073	852	744	676	591	561	—	—	—	—	—	—	—	—
	100000	1457	1010	852	676	591	537	469	445	—	—	—	—	—	—	—	—

See General Engineering page 276.

Load Capacity/Life Tables

Roller Bearings



TAPERED ROLLER BEARINGS 900 AND 950 SERIES

This chart displays the Browning 900 and 950 Series Tapered Roller Bearing's load capacity for a given L10 life, speed and shaft size. Values in the table represent loads at ideal conditions. The shaded areas indicate the maximum speed for the 950 series only. Select 950 Series where aligning capability is required. For combined load determination, see **THE BEARING SELECTION SECTION**, page 268. Areas designated by “-” exceed maximum speed value.

Table 12 Match Bore Size

SIZE	"K" FACTOR	"C" 2 ROW RATING	1 ROW RATING	THRUST RATING*	L10 HOURS	REVOLUTIONS PER MINUTE													
						50	100	150	250	500	750	1000	1500	1750	2000	2500	3000	3500	
1	1.42	3700	2130	1500	5000	4179	4179	4179	3908	3174	2811	2578	2283	2180	2094	1959	1854	1771	
					10000	4179	4179	3700	3174	2578	2283	2094	1854	1771	1701	1591	1506	1438	
					30000	3700	3005	2611	2283	1854	1642	1506	1334	1273	1144	1083	1034		
					50000	3174	2578	2283	1959	1591	1409	1292	1144	1093	1050	982	929	887	
					100000	2578	2094	1854	1591	1292	1144	1050	929	887	853	797	755	721	
1 3/16	1.53	5130	2950	1930	5000	5794	5794	5794	5418	4401	3897	3575	3165	3022	2904	2716	2571	2455	
					10000	5794	5794	5130	4401	3575	3165	2904	2571	2455	2358	2206	2088	1944	
					30000	5130	4167	3690	3165	2571	2277	2088	1849	1766	1696	1586	1502	1434	
					50000	4401	3575	3165	2716	2206	1953	1792	1586	1515	1455	1361	1289	1230	
					100000	3575	2904	2571	2206	1792	1586	1455	1289	1230	1182	1106	1047	999	
1 7/16	1.46	5930	3410	2330	5000	6697	6697	6697	6263	5087	4505	4132	3659	3494	3356	3139	2972	—	
					10000	6697	6697	5930	5087	4132	3659	3356	2972	2838	2726	2550	2414	—	
					30000	5930	4817	4265	3659	2972	2632	2414	2138	2041	1961	1834	1736	—	
					50000	5087	4132	3659	3139	2550	2258	2071	1834	1751	1682	1573	1490	—	
					100000	4132	3356	2972	2550	2071	1834	1682	1490	1422	1366	1278	1210	—	
1 5/8	1.37	6050	3470	2540	5000	6833	6833	6833	6390	5190	4596	4216	3733	3564	3424	3203	—	—	
					10000	6833	6833	6050	5190	4216	3733	3424	3032	2895	2781	2601	—	—	
					30000	6050	4914	4351	3733	3032	2685	2463	2181	2082	2000	1871	—	—	
					50000	5190	4216	3733	3203	2601	2303	2113	1871	1786	1716	1605	—	—	
					100000	4216	3424	3032	2601	2113	1871	1716	1520	1451	1394	1304	—	—	
1 7/8	1.65	8550	4910	2980	5000	9656	9656	8656	9031	7335	6495	5958	5276	5037	4839	—	—	—	
					10000	9656	9656	8550	7335	5958	5276	4839	4285	4091	3931	—	—	—	
					30000	8550	6945	6149	5276	4285	3794	3481	3082	2943	2827	—	—	—	
					50000	7335	5958	5276	4526	3676	3255	2986	2644	2525	2425	—	—	—	
					100000	5958	4839	4285	3676	2986	2644	2425	2148	2051	1970	—	—	—	
2 3/16	1.51	9090	5220	3470	5000	10266	10266	10266	9601	7798	6905	6334	5609	5355	5145	—	—	—	
					10000	10266	10266	9090	7798	6334	5609	5145	4556	4350	4179	—	—	—	
					30000	9090	7383	6538	5609	4556	4034	3700	3277	3129	3006	—	—	—	
					50000	7798	6334	5609	4812	3908	3461	3175	2811	2684	2579	—	—	—	
					100000	6334	5145	4556	3908	3175	2811	2579	2283	2180	2095	—	—	—	
2 1/4	1.45	9290	5340	3670	5000	10492	10492	10492	9812	7970	7057	6474	5732	5473	—	—	—	—	
					10000	10492	10492	9290	7970	6474	5732	5258	4656	4446	—	—	—	—	
					30000	9290	7546	6682	5732	4656	4123	3782	3349	3197	—	—	—	—	
					50000	7970	6474	5732	4918	3994	3537	3245	2873	2743	—	—	—	—	
					100000	6474	5258	4656	3994	3245	2873	2635	2334	2228	—	—	—	—	
2 11/16	1.30	9600	5510	4260	5000	10842	10842	10842	10140	8236	7293	6690	5924	5924	—	—	—	—	
					10000	10842	10842	9600	8236	6690	5924	5434	4811	—	—	—	—	—	
					30000	9600	7798	6905	5924	4811	4260	3908	3460	—	—	—	—	—	
					50000	8236	6690	5924	5082	4128	3655	3353	2969	—	—	—	—	—	
					100000	6690	5434	4811	4128	3353	2969	2723	2411	—	—	—	—	—	
3	1.31	14500	8330	6340	5000	16376	16376	16376	15315	12440	11015	10104	—	—	—	—	—	—	
					10000	16376	16378	14500	12440	10104	8947	8207	—	—	—	—	—	—	
					30000	14500	11778	10429	8947	7267	6435	5903	—	—	—	—	—	—	
					50000	12440	10104	8947	7676	6235	5521	5064	—	—	—	—	—	—	
					100000	10104	8207	7267	6235	5064	4484	4113	—	—	—	—	—	—	
3 7/16	1.19	15300	8790	7410	5000	17279	17279	17279	16160	13126	11623	10662	—	—	—	—	—	—	
					10000	17279	17279	15300	13126	10662	9441	8660	—	—	—	—	—	—	
					30000	15300	12427	11004	9441	7668	6790	6228	—	—	—	—	—	—	
					50000	13126	10104	9441	8099	6579	5825	5344	—	—	—	—	—	—	
					100000	10662	8207	7668	6579	5344	4732	4340	—	—	—	—	—	—	
3 15/16	1.45	18400	10600	7270	5000	20780	20780	20780	19434	15786	13978	12822	—	—	—	—	—	—	
					10000	20780	20780	18400	15786	12822	11353	10415	—	—	—	—	—	—	
					30000	18400	14945	13234	11353	9222	8166	7490	—	—	—	—	—	—	
					50000	15786	12822	11353	9740	7912	7005	6426	—	—	—	—	—	—	
					100000	12822	10415	9222	7912	6426	5690	5220	—	—	—	—	—	—	
4 7/16	1.91	25200	14500	7550	5000	28460	28460	28460	26617	21620	19143	17561	—	—	—	—	—	—	
					10000	28460	28460	25200	21620	17561	15549	14264	—	—	—	—	—	—	
					30000	25200	20469	18124	15549	12630	11183	10259	—	—	—	—	—	—	
					50000	21620	17561	15549	13340	10835	9594	8801	—	—	—	—	—	—	
					100000	17561	14264	12630	10835	8801	7793	7149	—	—	—	—	—	—	
4 15/16	1.82	26600	15300	8390	5000	30041	30041	30041	28095	22821	20207	—	—	—	—	—	—	—	
					10000	30041	30041	26600	22821	18536	16413	—	—	—	—	—	—	—	
					30000	26600	21606	19131	16413	13332	11805	—	—	—	—	—	—	—	
					50000	22821	18536	16413	14081	11437	10127	—	—	—	—	—	—	—	
					100000	18536	15056	13332	11437	9290	8226	—	—	—	—	—	—	—	

See General Engineering page 276.

TAPERED ROLLER BEARINGS 920 AND 970 SERIES

This chart displays the Browning 920 and 970 Series Tapered Roller Bearing's load capacity for a given L10 life, speed and shaft size. Values in the table represent loads at ideal conditions. The shaded areas indicate the maximum speed for the 970 series only. For combined load determination, see **THE BEARING SELECTION SECTION**, page 268. Areas designated by "-" exceed maximum speed value.

Table 13 Match Bore Size

SIZE	"K" FACTOR	"C" 2 ROW RATING	1 ROW RATING	THRUST RATING*	HOURS	REVOLUTIONS PER MINUTE																						
						50	100	150	250	500	750	1000	1500	1750	2000	2500	3000	3500	4000									
1 3/16 1 1/4	1.23	2975	1710	1390	5000	3360	3360	3360	3142	2552	2260	2073	1836	1753	1684	1575	1491	1424	1368	1279	1211	1156	1111					
					10000	3360	3360	2975	2552	2073	1836	1491	1424	1368	1279	1211	1156	1111										
					30000	2975	2416	2140	1836	1491	1320	1211	1072	1024	984	920	871	832	799									
					50000	2552	2073	1836	1575	1279	1133	1039	920	878	844	789	747	714	685									
					100000	2073	1684	1491	1279	1039	920	844	747	714	685	641	607	580	556									
1 3/8 1 7/16	1.31	4760	2740	2080	5000	5376	5376	5376	5028	4084	3616	3317	2937	2804	2694	2520	2386	2278	2188	2047	1938	1850	—					
					10000	5376	5376	4760	4084	3317	2937	2694	2386	2278	2188	2047	1938	1850	—									
					30000	4760	3866	3424	2937	2386	2112	1938	1716	1638	1574	1472	1394	1331	—									
					50000	4084	3317	2937	2520	2047	1812	1662	1472	1406	1350	1263	1196	1142	—									
					100000	3317	26741	2386	2047	1662	1472	1350	1196	1142	1097	1026	971	927	—									
1 1/2 1 11/16	1.36	6140	3530	2600	5000	6934	6934	6934	6485	5268	4664	4279	3789	3617	3475	3250	3077	—	—	—	—	—	—					
					10000	6934	6934	6140	5268	4279	3789	3475	3077	2938	2823	2640	2500	—										
					30000	6140	4987	4416	3789	3077	2725	2500	2213	2113	2030	1899	1798	—										
					50000	5268	4279	3789	3250	2640	2338	2144	1899	1813	1742	1629	1542	—										
					100000	4279	3475	3077	2640	2144	1899	1742	1542	1473	1415	1323	1253	—										
1 3/4 1 15/16 2	1.83	8070	4640	2540	5000	9114	9114	9114	8524	6923	6130	5624	4979	4754	4568	4272	—	—	—	—	—	—	—					
					10000	9114	9114	8070	6923	5624	4979	4568	4045	3862	3710	3470	—											
					30000	8070	6555	5804	4979	4045	3581	3285	2909	2777	2668	2496	—											
					50000	6923	5624	4979	4272	3470	3072	2818	2496	2383	2289	2141	—											
					100000	5624	4568	4045	3470	2818	2496	2289	2027	1935	1859	1739	—											
2 3/16	1.65	8570	4910	2980	5000	9679	9679	9679	9052	7352	6510	5972	5288	5049	4851	4537	—	—	—	—	—	—						
					10000	9679	9679	8570	7352	5972	5288	4851	4295	4101	3940	3685	—											
					30000	8570	6961	6164	5288	4295	3803	3489	3089	2950	2834	2650	—											
					50000	7352	5972	5288	4537	3685	3263	2993	2650	2530	2431	2274	—											
					100000	5972	4851	4295	3685	2993	2650	2431	2153	2055	1975	1847	—											
2 1/4 2 7/16 2 1/2	1.51	9030	5220	3470	5000	10198	10198	10198	9538	7747	6860	6293	5572	5320	5111	—	—	—	—	—	—	—						
					10000	10198	10198	9030	7747	6293	5572	5111	4526	4321	4152	—												
					30000	9030	7335	6495	5572	4526	4007	3676	3255	3108	2986	—												
					50000	7747	6293	5572	4780	3883	3438	3154	2793	2666	2562	—												
					100000	6293	5111	4526	3883	3154	2793	2562	2268	2166	2081	—												
2 11/16 2 15/16 3	1.30	9630	5510	4260	5000	10876	10876	10876	10171	8262	7316	6711	5942	5674	—	—	—	—	—	—	—	—						
					10000	10876	10876	9630	8262	6711	5942	5451	4826	4608	—													
					30000	9630	7822	6926	5942	4826	4274	3920	3471	3314	—													
					50000	8262	6711	5942	5098	4141	3666	3363	2978	2843	—													
					100000	6711	5451	4826	4141	3363	2978	2732	2419	2310	—													
3 3/16 3 7/16 3 1/2	1.19	15320	8790	7410	5000	17302	17302	17302	16181	13143	11638	10676	9453	—	—	—	—	—	—	—	—	—						
					10000	17302	17302	15320	13143	10676	9453	8671	7678	—														
					30000	15320	12444	11018	9453	7678	6799	6273	5522	—														
					50000	13143	10676	9453	8110	6587	5833	5351	4738	4346	—													
					100000	10676	8671	7678	6587	5351	4738	4346	3848	—														
3 15/16 4	1.23	20980	12100	9800	5000	23694	23694	23694	22159	17999	15938	14620	12945	—	—	—	—	—	—	—	—	—						
					10000	23694	23694	20980	17999	14620	12945	11875	10515	—														
					30000	20980	17041	15089	12945	10515	9311	8411	7563	—														
					50000	17999	14620	12945	11106	9021	7988	7327	6488	—														
					100000	14620	11875	10515	9021	7327	6488	5952	5270	—														
4 7/16 4 1/2	1.13	25750	14800	13100	5000	29081	29081	29081	27198	22091	19561	17944	—	—	—	—	—	—	—	—	—	—						
					10000	29081	29081	25750	22091	17944	15889	14575	—															
					30000	25750	20915	18520	15889	12906	11427	10483	—															
					50000	22091	17944	15889	13631	11072	9804	8993	—															
					100000	17944	14575	12906	11072	8993	7963	7305	—															
4 15/16 5	1.27	35520	20400	16000	5000	40114	40114	40114	37517	30473	26983	24752	—	—	—	—	—	—	—	—	—	—						
					10000	40114	40114	35520	30473	24752	21917	20105	—															
					30000	35520	28851	25547	21917	17802	15763	14460	—															
					50000	30473	24752	21917	18803	15273	13524	12405	—															
					100000	24752	20105	17802	15273	12405	10985	10076	—															

See General Engineering page 276.

Load Capacity/Life Tables

Roller Bearings



SPHERICAL ROLLER BEARINGS 1000 AND 1100 SERIES

This chart displays the Browning 1000 and 1100 Series Spherical Roller Bearing's load capacity for a given L10 life, speed and shaft size. Values in the table represent loads at ideal conditions. The shaded areas indicate the maximum speed for the MULTI-TRAP Seal. The maximum speed for the Contact Seal is indicated in the non-shaded areas. For combined load determination, see **THE BEARING SELECTION SECTION**, page 269. Areas designated by “-” exceed maximum speed value.

Table 14 Match Bore Size

Size	Rating	L10 Hours	REVOLUTIONS PER MINUTE												
			50	100	150	250	500	750	1000	1500	1750	2000	2500	3000	3500
1 1/8	16600	5000	4880	4880	4880	4546	3692	3269	2999	2656	2535	2436	2278	2157	2059
1 3/16		10000	4880	4860	4304	3692	2999	2656	2436	2157	2059	1979	1850	1752	1673
1 1/4		30000	4304	3496	3095	2656	2157	1910	1752	1551	1481	1423	1331	1260	1203
1 7/16		50000	3692	2999	2656	2278	1850	1639	1503	1331	1271	1221	1142	1081	1032
1 1/2		100000	2999	2436	2157	1850	1503	1331	1221	1081	1032	992	927	878	838
1 11/16	17300	5000	2999	6458	5522	4737	3848	3407	3125	2767	2642	2539	2374	2248	2146
1 3/4		10000	6458	5065	4485	3848	3125	2767	2539	2248	2146	2062	1929	1826	1743
		30000	6458	3643	3226	2767	2248	1990	1826	1617	1544	1483	1387	1313	1254
		50000	4485	3125	2767	2374	1929	1708	1566	1387	1324	1272	1190	1127	1076
		100000	3848	2539	2248	1929	1566	1387	1272	1127	1076	1033	967	915	874
1 15/16	19000	5000	3125	6925	6064	5203	4226	3742	3433	3039	2902	2788	2608	2469	2357
2		10000	6925	5563	4926	4226	3433	3039	2788	2469	2357	2265	2118	2005	1915
		30000	6925	4001	3543	3039	2469	2186	2005	1776	1695	1629	1523	1442	1377
		50000	4926	3433	3039	2608	2118	1875	1720	1523	1454	1397	1307	1237	1181
		100000	4226	2788	2469	2118	1720	1523	1397	1237	1181	1135	1062	1005	960
2 3/16	22400	5000	3433	7150	7150	6134	4982	4412	4047	3583	3421	3287	3074	2911	2779
		10000	7150	6559	5807	4982	4047	3583	3287	2911	2779	2670	2497	2364	2257
		30000	7150	4717	4177	3583	2911	2577	2364	2093	1999	1920	1796	1700	1623
		50000	5807	4047	3583	3074	2497	2211	2028	1796	1715	1647	1541	1459	1393
		100000	4982	3287	2911	2497	2028	1796	1647	1459	1393	1338	1251	1185	1131
2 7/16	33300	5000	4047	10629	10629	9119	7407	6558	6016	5327	5086	4887	4570	4327	—
2 1/2		10000	10629	9750	8633	7407	6016	5327	4887	4327	4131	3969	3712	3515	—
		30000	10629	7012	6209	5327	4327	3831	3515	3112	2971	2855	2670	2528	—
		50000	8633	6016	5327	4570	3712	3287	3015	2670	2549	2449	2290	2169	—
		100000	7407	4887	4327	3712	3015	2670	2449	2169	2071	1989	1860	1761	—
2 11/16	35500	5000	6016	11331	11331	9721	7896	6992	6413	5679	5422	5209	4872	4613	—
2 3/4		10000	11331	10394	9204	7896	6413	5679	5209	4613	4404	4231	3957	3747	—
2 15/16		30000	11331	7476	6619	5679	4613	4084	3747	3318	3168	3043	2846	2695	—
3		50000	9204	6413	5679	4872	3957	3504	3214	2846	2718	2611	2442	2312	—
		100000	7896	5209	4613	3957	3214	2846	2611	2312	2207	2121	1983	1878	—
3 3/16	56900	5000	6413	20827	18161	15581	12656	11206	10280	9102	8691	8350	—	—	—
3 7/16		10000	20827	16660	14752	12656	10280	9102	8350	7393	7059	6782	—	—	—
3 1/2		30000	20827	11982	10610	9102	7393	6547	6005	5317	5077	4878	—	—	—
		50000	14752	10280	9102	7809	6343	5616	5152	4562	4356	4185	—	—	—
		100000	12656	8350	7393	6343	5152	4562	4185	3705	3538	3399	—	—	—
3 11/16	69900	5000	10280	25854	22311	19141	15547	13767	12628	11182	10677	10257	—	—	—
3 15/16		10000	25854	20466	18122	15547	12628	11182	10257	9083	8672	8332	—	—	—
4		30000	25854	14720	13034	11182	9083	8042	7377	6532	6237	5992	—	—	—
		50000	18122	12628	11182	9593	7792	6900	6329	5604	5351	5141	—	—	—
		100000	15547	10257	9083	7792	6329	5604	5141	4552	4346	4176	—	—	—
4 7/16	91700	5000	12628	33386	29269	25110	20396	18060	16567	—	—	—	—	—	—
4 1/2		10000	33386	26849	23774	20396	16567	14669	13456	—	—	—	—	—	—
		30000	33386	19310	17099	14669	11915	10550	9678	—	—	—	—	—	—
		50000	23774	16567	14669	12585	10222	9051	8303	—	—	—	—	—	—
		100000	20396	13456	11915	10222	8303	7352	6744	—	—	—	—	—	—
4 15/16	123,000	5000	16567	45244	39259	33681	27358	24224	—	—	—	—	—	—	—
		10000	45244	36013	31889	27358	22221	19676	—	—	—	—	—	—	—
		30000	45244	25902	22935	19676	15982	14152	—	—	—	—	—	—	—
		50000	31889	22221	19676	16881	13711	12141	—	—	—	—	—	—	—
		100000	27358	18049	15982	13711	11137	9862	—	—	—	—	—	—	—

See General Engineering page 276.

SPHERICAL ROLLER BEARINGS 22200 AND 22500 SERIES

This chart displays the Browning 22200 and 22500 Series Spherical Roller Bearing's load capacity for a given L10 life, speed and shaft size. Values in the table represent loads at ideal conditions. For combined load determination, see **THE BEARING SELECTION SECTION**, page 269. Areas designated by "-" exceed maximum speed value.

Table 15 Match Bore Size

Size	Rating	L10 Hours	REVOLUTIONS PER MINUTE												
			50	100	150	250	500	750	1000	1500	1750	2000	2500	3000	3500
22215	47,700	5000	13966	13966	13966	13966	10609	9394	8618	7631	7286	7000	6546	6198	—
		10000	13966	13966	12367	10609	8618	7631	7000	6198	5918	5685	5317	5034	—
		30000	12367	10045	8894	7631	6198	5488	5034	4458	4256	4089	3824	3621	—
		50000	10609	8618	7631	6546	5317	4708	4319	3824	3652	3508	3281	3106	—
		100000	8618	7000	6198	5317	4319	3824	3508	3106	2966	2849	2665	2523	—
22216	53,100	5000	15550	15550	15550	14540	11811	10458	9593	8494	8111	7792	7288	6900	—
		10000	15550	15550	13767	11811	9593	8494	7792	6900	6588	6329	5919	5604	—
		30000	13767	11182	9901	8494	6900	6109	5604	4962	4738	4552	4257	4031	—
		50000	11811	9593	8494	7288	5919	5241	4808	4257	4065	3905	3652	3458	—
		100000	9593	7792	6900	5919	4808	4257	3905	3458	3302	3172	2967	2809	—
22217	55,100	5000	16134	16134	16134	15088	12255	10852	9954	8814	8416	8086	7562	7159	—
		10000	16134	16134	14285	12255	9954	8814	8086	7159	6836	6567	6142	5815	—
		30000	14285	11603	10274	8814	7159	6339	5815	5149	4917	4723	4418	4183	—
		50000	12255	9954	8814	7562	6142	5439	4989	4418	4218	4052	3790	3588	—
		100000	9954	8086	7159	6142	4989	4418	4052	3588	3426	3292	3078	2915	—
22218	73,100	5000	21405	21405	21405	20017	16259	14397	13206	11694	11165	10727	10032	—	—
		10000	21405	21405	18952	16259	13206	11694	10727	9498	9069	8713	8149	—	—
		30000	18952	15394	13630	11694	9498	8410	7715	6831	6523	6267	5861	—	—
		50000	16259	13206	11694	10032	8149	7215	6619	5861	5596	5376	5028	—	—
		100000	13206	10727	9498	8149	6619	5861	5376	4760	4545	4367	4084	—	—
22220	95,500	5000	27965	27965	27965	26151	21241	18808	17253	15277	14587	14014	13883	—	—
		10000	27965	27965	24759	21241	17253	15277	14014	12409	11848	11383	—	—	—
		30000	24759	20111	17807	15277	12409	10988	10079	8925	8521	8187	—	—	—
		50000	21241	17253	15277	13107	10646	9427	8647	7657	7311	7024	—	—	—
		100000	17253	14014	12409	10646	8647	7657	7024	6219	5938	5705	—	—	—
22222	105,000	5000	30745	30745	30745	28752	23354	20679	18969	16797	16038	15408	—	—	—
		10000	30745	30745	27222	23354	18969	16797	15408	13643	13027	12515	—	—	—
		30000	27222	22111	19579	16797	13643	12081	11082	9813	9369	9001	—	—	—
		50000	23354	18969	16797	14410	11705	10364	9507	8418	8038	7722	—	—	—
		100000	18969	15408	13643	11705	9507	8418	7722	6838	6529	6272	—	—	—
22224	121,000	5000	35430	35430	35430	33134	26913	23831	21860	19356	18482	—	—	—	—
		10000	35430	35430	31370	26913	21860	19356	17756	15722	15012	—	—	—	—
		30000	31370	25480	22562	19356	15722	13922	12770	11308	10797	—	—	—	—
		50000	26913	21860	19356	16606	13488	11944	10956	9701	9263	—	—	—	—
		100000	21860	17756	15722	13488	10956	9701	8899	7880	7524	—	—	—	—
22226	142,000	5000	41580	41580	41580	38884	31584	27966	25654	22716	21689	—	—	—	—
		10000	41580	41580	36814	31584	25654	22716	20837	18451	17617	—	—	—	—
		30000	36814	29903	26478	22716	18451	16338	14987	13270	12671	—	—	—	—
		50000	31584	25654	22716	19488	15829	14016	12857	11385	10870	—	—	—	—
		100000	25654	20837	18451	15829	12857	11385	10443	9247	8829	—	—	—	—
22228	160,000	5000	46850	46850	46850	43813	35587	31511	28906	25595	—	—	—	—	—
		10000	46850	46850	41481	35587	28906	25595	23479	20790	—	—	—	—	—
		30000	41481	33693	29834	25595	20790	18409	16887	14952	—	—	—	—	—
		50000	35587	28906	25595	21959	17836	15793	14487	12828	—	—	—	—	—
		100000	28906	23479	20790	17836	14487	12828	11767	10420	—	—	—	—	—
22230	191,000	5000	55930	55930	55930	52302	42482	37617	34506	30554	—	—	—	—	—
		10000	55930	55930	49518	42482	34506	30554	28028	24818	—	—	—	—	—
		30000	49518	40221	35614	30554	24818	21975	20158	17850	—	—	—	—	—
		50000	42482	34506	30554	26213	21292	18853	17294	15313	—	—	—	—	—
		100000	34506	28028	24818	21292	17294	15313	14047	12438	—	—	—	—	—
22232	225,000	5000	65885	65885	65885	61612	50045	44313	40649	35993	—	—	—	—	—
		10000	65885	65885	58333	50045	40649	35993	33017	29236	—	—	—	—	—
		30000	58333	47381	41954	35993	29236	25887	23747	21027	—	—	—	—	—
		50000	50045	40649	35993	30879	25082	22209	20373	18039	—	—	—	—	—
		100000	40649	33017	29236	25082	20373	18039	16548	14653	—	—	—	—	—
22234	252,000	5000	73790	73790	73790	69006	56050	49630	45527	—	—	—	—	—	—
		10000	73790	73790	65333	56050	45527	40312	36979	—	—	—	—	—	—
		30000	65333	53067	46989	40312	32744	28994	26596	—	—	—	—	—	—
		50000	56050	45527	40312	34585	28092	24874	22817	—	—	—	—	—	—
		100000	45527	36979	32744	28092	22817	20204	18534	—	—	—	—	—	—
22236	265,000	5000	77600	77600	77600	69006	56050	49630	45527	—	—	—	—	—	—
		10000	77600	77600	65333	56050	45527	40312	36979	—	—	—	—	—	—
		30000	65333	53067	46989	40312	32744	28994	26596	—	—	—	—	—	—
		50000	56050	45527	40312	34585	28092	24874	22817	—	—	—	—	—	—
		100000	45527	36979	32744	28092	22817	20204	18534	—	—	—	—	—	—
22238	250,000	5000	73198	73198	73198	68458	55605	49237	45165	—	—	—	—	—	—
		10000	73198	73198	64814	55605	45165	39993	36686	—	—	—	—	—	—
		30000	64814	52645	46616	39993	32484	28764	26385	—	—	—	—	—	—
		50000	55605	45165	40312	34585	28092	24874	22817	—	—	—	—	—	—
		100000	45165	36686	32484	28764	26385	24044	21838	—	—	—	—	—	—
22240	328,000	5000	96045	96045	96045	89817	72954	64598	59257	—	—	—	—	—	—
		10000	96045	96045	85036	72954	59257	52470	48132	—	—	—	—	—	—
		30000	85036	69071	61160	52470	42619	37738	34617	—	—	—	—	—	—
		50000	72954	59257	52470	45015	36564	32376	29699	—	—	—	—	—	—
		100000	59257	48132	42619	36564	29699	26297	24123	—	—	—	—	—	—
22244	396,000	5000	115960	115960	115960	108437	88079	77991	—	—	—	—	—	—	—
		10000	115960	115960	102666	88079	71542	63348	—	—	—	—	—	—	—
		30000	102666	83390	73839	63348	51455	45561	—	—	—	—	—	—	—
		50000	89079	71542	63348	54347	44144	39088	—	—	—	—	—	—	—
		100000	71542	58110	51455										

BEARING SELECTION:

Consult EPT Mounted Bearing Technical Support for

1. Moderate to High Thrust Load Applications
2. Housing Strength and Capabilities
3. High Load/High Speed Applications
4. See Bearing Dimension/Data Tables for General Bearing Capabilities

LINEAL SHAFT EXPANSION

Lineal shaft expansion is the change in length of a shaft due to a relative change in its temperature. For steel shafts, lineal expansion can be calculated using the following formula:

$$\text{Expansion (Growth)} = .0000063 \times \text{Length (inches)} \times \text{Temperature Change } ^\circ\text{F}$$

The following Roller Bearings can accommodate shaft lineal expansion as listed in the table below.

Table 16

Series	Lineal Expansion Capability
950, 970	.310 inched
1000, 1100, thru 1-3/4"	.050 inches
1000/1100 1-15/16 up	.080 inches
22200/22500	.080 inches

Consult EPT Mounted Bearing Tech Support for applications where lineal expansion is a factor on other types of Browning Bearing Products or the lineal expansion exceeds the capability of the Roller Bearings listed above.

**BEARING ALIGNMENT CAPABILITY (IN)
ALLOWABLE ALIGNMENT ERROR (IN)**

Table 17

	DISTANCE BETWEEN BEARINGS (feet)									
	1 Ft.	2 Ft.	3 Ft.	4 Ft.	5 Ft.	6 Ft.	7 Ft.	8 Ft.	9 Ft.	10 Ft.
Labyrinth (Multi-trap) 1000/1100 950/970/Ball *	.3	0.6	.9	1.3	1.6	1.9	2.2	2.5	2.8	3.63
Contact (Double Lip) 1000/1100	.25	.5	.8	1.0	1.3	1.6	1.8	2.1	2.4	2.6
22500 (LER) 22200 (LER)	.05	.1	.2	.2	.3	.3	.4	.4	.5	.5

* Ball except cylindrical O. D. inserts

SEALS

- 900/950 series bearings are designed with metal labyrinth seals. Labyrinth seals rely on frequent lubrication for full effectiveness. 920 and 970 series bearings with contact seals should be selected in moist, wet or highly contaminated environments.
- 1000/1100 series are standard with metal labyrinth seals. Labyrinth seals rely on frequent lubrication for full effectiveness. Contact seals should be specified in moist, wet or highly contaminated environments.

EMERSON POWER TRANSMISSION

EPT MOUNTED BEARING DIVISION

Mail To: EPT Bearing Operations - Application Engineering
 909 N. Lafayette St.
 Valparaiso, IN 46383

Fax to: Application Engineering 219-465-2290

Distributor Information		Customer Information	
Distributor Name		Company Name	
Contact Name		Contact Name	
Street Address		Street Address	
City/State/Zip		City/State/Zip	
Phone		Phone	
Fax		Fax	
E-Mail		E-Mail	
Is the Customer an: OEM or End User		Industry	
Application Information			
Is this a new application		Yes or No	
Speed: (rpm)		EXPLAIN: Climate Conditions: Wet <input type="checkbox"/> Washdown <input type="checkbox"/> Dry <input type="checkbox"/> Clean <input type="checkbox"/> Dirty <input type="checkbox"/> Chemicals <input type="checkbox"/>	
Service Life Required: (hours):			
Shaft Diameter:			
Load Information (lbs.): Load Conditions: Steady <input type="checkbox"/>		Operating Temperature (°F):	
Radial (lbs.): Shock <input type="checkbox"/>		Is the bearing in the elevated temp? Yes / No	
Axial / Thrust (lbs.): Thrust <input type="checkbox"/>		Is the heat coming through the shaft? Yes / No	
If loads unknown attach detailed sketch*** Oscillation <input type="checkbox"/>		Can the bearings be re-lubricated? Yes <input type="checkbox"/> No <input type="checkbox"/>	
If loads unknown attach detailed sketch*** Other <input type="checkbox"/>			
Complete Application Description: Horsepower (bhp):		Motor	
		Driven Pulley Diameter (in.):	
		Distance Between Bearings:	
***PLEASE ATTACH DETAILED SKETCH OF APPLICATION. INCLUDE ALL DIMENSIONS AND SYSTEM LOAD LOCATIONS			

APPLICATION EXAMPLES:

EXAMPLE # 1 Pure Radial Load

Question # 1:

What is the adjusted bearing life (L_{na} hours) for an VPS-239 Browning Ball Bearing with no shock conditions and the following application criteria?

Design Load (P)	=	1300 lbs.
Speed (n)	=	1000 RPM
Shaft Size	=	2 ⁷ / ₁₆ Inches
Operating Temperature	=	125°F

Solution:

1. Begin with the L_{10} life formula: $L_{10} = (C/P)^3 \times \frac{16667}{n}$

Look up the insert of an VPS-239 on page 6. From Table 4 on page 269, the Basic Dynamic Radial Rating is 11,789 lbs.

$$L_{10} = \left(\frac{11789}{1300} \right)^3 \times \frac{16667}{1000} = 12,430 \text{ hours}$$

2. Apply the life adjustment factors:

$$\begin{aligned} L_{na} \text{ hours} &= L_{10} \times a_1 \times a_2 \times a_3 \\ L_{na} \text{ hours} &= 12,430 \times 1 \times 1 \times 0.456 \\ L_{na} \text{ hours} &= 5,700 \text{ hours}^* \end{aligned}$$

Question # 2:

What is the adjusted bearing life (L_{10} hours) for an VPS-39 Browning Ball Bearing with moderate shock conditions and the same application criteria from above?

Solution:

1. From Table 2 on page 262: $a_3 = 0.5 \times 0.456$.
2. Re-Apply the life adjustment factors to the previously calculated L_{10} life:

$$\begin{aligned} L_{na} \text{ hours} &= L_{10} \times a_1 \times a_2 \times a_3 \\ L_{na} \text{ hours} &= 12,430 \times 1 \times 1 \times (0.5 \times 0.456) \\ L_{na} \text{ hours} &= 2,830 \text{ hours}^* \end{aligned}$$

Question # 3:

What is the bearing life (L_{10} hours) for an PB-970NEx 2 7/16 Tapered Roller Bearing with no shock conditions and the same application criteria from above?

Solution:

1. Begin with the L_{10} life formula: $L_{10} = (C/P)^{10/3} \times \frac{500 \times 3,000}{n}$
2. PB-970NEx 2 7/16 has 2 7/16" shaft size. From Table 13 x on page 269, the Radial Rating is 9,030 lbs.

$$L_{10} = \left(\frac{9030}{1300} \right)^{10/3} \times \frac{500 \times 3,000}{1000} = 959,000 \text{ hrs.}$$

For moderate shock (from table 5) $L_{10} = .5^* 959,000 = 480,000 \text{ hrs}^*$

Question # 4:

What is the bearing life (L_{10} hours) for an SPB-1000NEx 2 7/16 Spherical Roller Bearing with moderate shock conditions and the same application criteria from above?

Solution:

1. From Table No. 14 on page 270:

$$L_{10} = ? \times \left(\frac{32,400}{1300} \right)^{10/3} \times \frac{16,667}{1000} = 754,000^* \text{ hrs.}$$

For moderate shock (from Table 6 page 269)

$$L_{10} = .5 \times 754,000 = 377,000 \text{ hrs}^*$$

* Excessively high or low hours are not realistic in applications.

EXAMPLE # 2 Combined Radial and Thrust Load

Question # 1:

What is the adjusted bearing life (L_{na} hours) for an VPS-239 Browning Ball Bearing with no shock conditions and the following application criteria?

Design Radial Load (F_r)	=	500 lbs.
Design Thrust Load (F_a)	=	1000 lbs.
Speed (n)	=	1000 RPM
Shaft Size	=	2 ⁷ / ₁₆ Inches
Operating Temperature	=	125°F

Solution:

1. Calculate $F_a/F_r = 1000/500 = 2$
2. Begin by calculating the Relative Axial Load (RAL): (From Table 3, page 267)

$$RAL = \frac{F_a}{F_r} = \frac{1000}{3.9690} = 251 \text{ lbs.}$$

3. From Table 3 on page 263, interpolate RAL between 200.10 and 300.15 and "e" between 0.30 and 0.34 to obtain an "e" value:

$$\frac{251 - 200.10}{300.15 - 200.10} = \frac{e - 0.30}{0.34 - 0.30} \quad \text{Therefore } e = .32$$

4. From Table 3 on page 267, determine the value of "X" and "Y" through interpolation. Interpolate "e" between 0.30 and 0.34 and "Y" between 1.45 and 1.31 because $F_a/F_r > e$;

$$\frac{0.32 - 0.30}{0.34 - 0.30} = \frac{Y - 1.45}{1.31 - 1.45}$$

Therefore $Y = 1.38$

$$X = .56$$

5. Determine the equivalent radial load (P):

$$\begin{aligned} P &= (X F_r) + (Y F_a) \\ &= (0.56 \times 500) + (1.38 \times 1000) = 1660 \text{ lbs.} \end{aligned}$$

$$L_{10} = (C/P)^3 \times \frac{16667}{n}$$

Look up the insert of an VPS-239 on page 6. From Table 4 on page 267, the Basic Dynamic Radial Rating is 11,789 lbs.

$$L_{na} = .456 \times \left(\frac{11789}{1660} \right)^3 \times \frac{16667}{1000} = 2720 \text{ hours}$$

Question # 2:

What is the bearing life (L_{10} hours) for an PB-970NEx 2 7/16 Tapered Roller Bearing with no shock conditions and the same application criteria from above?

Solution:

1. Find the K factor value from Table 13 on page 273, $K = 1.51$.
2. Calculate the internal thrust reaction (FIR):

$$FIR = \frac{0.6 \times F_r}{K} \quad \text{-applied radial load}$$

-factor K in Table 13

$$FIR = \frac{0.6 \times 500}{1.51} = 199 \text{ lbs.}$$

3. Since the thrust load is greater than the internal thrust reaction (FIR) use the following formula from page 268 to calculate the equivalent radial load.

$$P = (0.4 \times F_r) + (K \times F_a)$$

$$P = (0.4 \times 500) + (1.51 \times 1000) = 1710 \text{ lbs.}$$

4. Calculate the expected L_{10} life using the single row rating. Single row rating = 5,220 lbs. This is found in Table 13 on page 273.

$$L_{10} = \left(\frac{\text{single row load rating}}{P} \right)^{10/3} \times \frac{500 \times 3000}{n}$$

$$L_{10} = \left(\frac{5220}{1710} \right)^{10/3} \times \frac{3000 \times 500}{1000} = 61,900 \text{ hrs.}$$

See page 156 for trademark acknowledgments.

COMPUTING BEARING LOADS:

In the computation of bearing loads in any application of a Browning unit, the principal factor determining the selection of the unit is the equivalent radial load to which the bearing will be subjected. These radial loads result from any one or any combination of the following sources:

1. Weights of machine parts supported by bearings.
2. Tension due to belt or chain pull.
3. Centrifugal force from out of balance, eccentric or cam action.

The resulting load from any one, or any combination of the above sources is further determined by knowing:

1. The magnitude of the load.
2. Direction of the load.
3. The point of load application.
4. The distance between bearing centers.

Bearing loads are the result of force acting on the shaft. Direction, magnitude, and location with respect to the bearings must be considered when calculating bearing loads. The following cases are typical examples of loads encountered and methods of calculating bearing loads.

CASE # 1
Straddle Mount Fan, Cantilever Drive

Load on Bearing A = $\frac{(P_1 \times b) - (P_2 \times c)}{k}$

$$= \frac{(1,000 \times 4) - (150 \times 3)}{11} = 323 \text{ lbs.}$$

Load on Bearing B = $\frac{(P_1 \times a) + (c + k) \times (P_2)}{k}$

$$= \frac{(1,000 \times 7) + (3 + 11) \times (150)}{11} = 827 \text{ lbs.}$$

CASE # 2
Cantilever Fan and Drive

Load on Bearing A = $\frac{P_1 \times (a + k) - (P_2 \times b)}{k}$

$$= \frac{200 \times (4 + 9) - (80 \times 2)}{9} = 271 \text{ lbs.}$$

Load on Bearing B = $\frac{(P_2 \times (k + b) - (P_1 \times a))}{k}$

$$= \frac{80 \times (9 + 2) - (200 \times 4)}{9} = 9 \text{ lbs.}$$

CASE # 3
Straddle, Cantilever Fan, Cantilever Drive

Load on Bearing A = $\frac{P_1 \times (k + a) + (P_2 \times c) - (P_3 \times d)}{k}$

$$= \frac{60 \times (12 + 2) + (180 \times 6) - (70 \times 4)}{12} = 137 \text{ lbs.}$$

Load on Bearing B = $\frac{-(P_1 \times a) + (P_2 \times b) + P_3 \times (k + d)}{k}$

$$= \frac{-(60 \times 2) + (180 \times 6) + 70 \times (12 + 4)}{12} = 173 \text{ lbs.}$$

CASE # 4
Drive Load Calculation

$$P = \frac{126,000 \times \text{HP}}{\text{RPM} \times d} \times K = \frac{126,000 \times 5}{2,400 \times 10} \times 1.5 = 39.4 \text{ lbs.}$$

HP = horsepower
 RPM = revolutions per minute
 d = pitch diameter of pulley in inches
 K = constant for type of drive used
 K = 1.5 for V-belts
 K = 2 to 3 for flat transmission belts
 K = 1.1 for chain drives

Apply P to Case 1, 2 or 3 if applicable

Installation Instructions

Set Screw Locking



SET SCREW LOCK

1 INSPECT SHAFT

- Clean/remove burrs.
- Check diameter -Ref tables 25, 27, 35.
- Clean Mounting Surface.
- Mounting Surfaces Must be Flat.

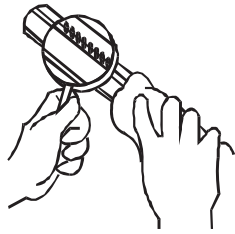

2 PLACE BEARING ON SHAFT

- Apply light film of oil on shaft.
- Slide, do not hammer, bearing onto shaft.



3 BOLT HOUSING TO SUPPORT SURFACE

- Bearing and shaft must be in alignment.
- Ball - 1 1/2° max
- 1000/1100 - 1 1/2° max
- 1000/1100 w/contact seals - 1 1/2° max
- 920 - 1/20° max
- 970 - 1 1/4° max
- VER 1/20° max
- Rotate shaft to make sure it rotates.

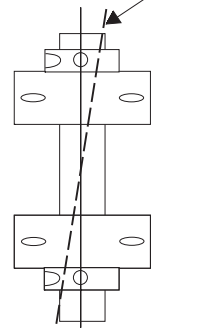

4 ALIGN SETSCREWS ON BOTH BEARINGS IN LINE

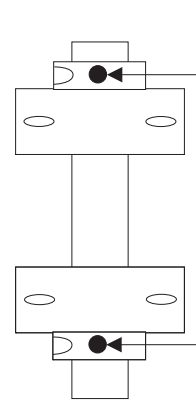

5 ALTERNATE TORQUING OF SETSCREWS

See Torque Specification Tables

- Step 1: Torque setscrew "A" to 1/2 recommended torque. In tables 18, 19, 20
- Step 2: Torque setscrew "B" to full recommended torque. In tables 18, 19, 20
- Step 3: Torque setscrew "A" to full recommended torque. In tables 18, 19, 20
- Double Lock: Repeat on opposite end.

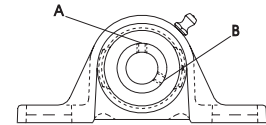

Set Screw Tightening Torque

Table 18 Ball Bearings

Bearing Bore 100-200 Series (Inches)	Bore Size 300 series (Inches)	Set Screw Diameter	Hex Size Across Flats	Recommended Torque	
				(Inch Lbs.)	(Foot Lbs.)
1/2 - 5/8		10 - 32	3/32	28 - 36	
3/4 - 1 1/4S	1	1/4 - 28	1/8	66 - 85	
1 1/4 - 1 3/4	1 3/16 - 1 1/2	5/16 - 24	5/32	126 - 164	11 - 14
1 15/16 - 2 7/16	1 11/16 - 2 3/16	3/8 - 24	3/16	228 - 296	19 - 25
2 1/2 - 2 15/16	2 7/16 - 3	7/16 - 20	7/32	348 - 452	29 - 38
3 1/2	3 7/16	1/2 - 20	1/4	504 - 655	42 - 54
	3 15/16	5/8 - 18	5/16	1104 - 1435	92 - 119

Table 19 920/970 Tapered Roller

Bearing Bore (inches)	Set Screw Diameter (inches)	Recommended Torque	
		(In-Lbs)	(Ft-Lbs)
1 3/16 to 1 11/16	5/16 - 24	108 - 144	9 - 12
1 3/4 to 2 1/2	3/8 - 24	180 - 228	15 - 19
2 11/16 to 3 1/2	1/2 - 20	408 - 540	34 - 45
3 15/16 to 4	5/8 - 18	876 - 1140	73 - 95
4 7/16 to 5	3/4 - 16	1440 - 1800	120 - 150

Table 20 1000/1100 Spherical Roller

Bearing Bore (inches)	Set Screw Diameter (inches)	Recommended Torque	
		(In-Lbs)	(Ft-Lbs)
1 1/8 to 2 3/16	3/8 - 24	290 - 380	24 - 32
2 7/16 to 3 7/16	1/2 - 20	620 - 930	50 - 45
3 1/2 to 4 15/16	5/8 - 18	1300 - 1700	108 - 140

Monitor operating bearing during first 48 hours for unusual vibration or temperatures.

⚠ WARNING
Failure to observe safety precautions could cause personal injury or equipment damage.

⚠ WARNING
Do not operate without guards. Turn off power to install or service

⚠ CAUTION
High voltage and rotating parts may cause serious or fatal injury. Turn off power to install or service.

BOA CONCENTRIC LOCKING

1 INSPECT SHAFT

- Clean/remove burrs.
- Check diameter. Reference Table 25.
- Clean Mounting Surface.
- Mounting Surface Must be Flat.

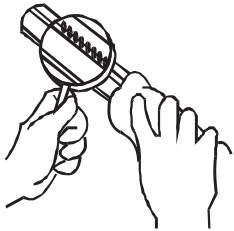

2 PLACE BEARING ON SHAFT

- Slide, do not hammer, bearing onto shaft.



3 BOLT HOUSING TO SUPPORT SURFACE

- Bearing and shaft must be in alignment max 1 1/2°.
- Rotate shaft to make sure it rotates.

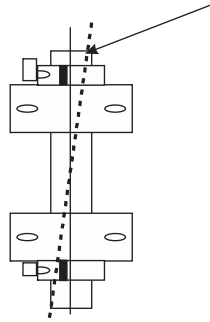

4 PUSH LOCKING COLLAR TIGHTLY AGAINST INNER RING SHOULDER

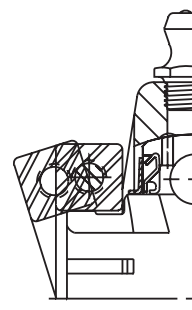

5 TORQUE CAPSCREW TO RECOMMENDED VALUE

See Torque Specification Table 21

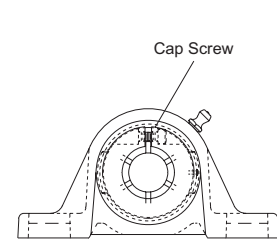
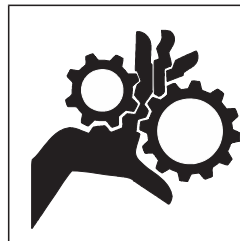

Table 21 BOA Concentric Cap Screw Tightening Torque

Bearing Bore Normal Duty (Inches)	Bearing Bore Medium Duty (inches)	Thread Size	Torx Size	Recommended Torque	
				(Inch Lbs.)	(Foot Lbs.)
3/4 - 1 1/4R	15/16-1	8-32	T-25	65 - 70	-
1 1/4 - 1 3/4	1 3/16-1 1/2	10-24	T-27	90 - 100	-
1 13/16 - 2 3/16	1 11/16-1 15/16	1/4-20	T-30	220 - 240	18 - 20
2 1/4 - 2 7/16	2 3/16	5/16-18	T-45	450 - 495	37 - 41

Monitor operating bearing during first 48 hours for unusual vibration or temperatures.

▲WARNING
Failure to observe safety precautions could cause personal injury or equipment damage.



▲WARNING
Do not operate without guards. Turn off power to install or service



▲CAUTION
High voltage and rotating parts may cause serious or fatal injury. Turn off power to install or service.

Installation Instructions

Eccentric Lock



ECENTRIC LOCK

① INSPECT SHAFT (TABLE 1)

- Clean/remove burrs.
- Check diameter - Ref table 25, 31.
- Clean Mounting Surface.
- Mounting Surfaces Must be Flat.

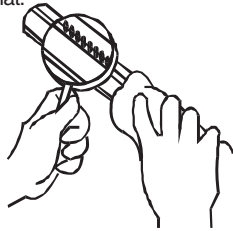

② PLACE BEARING ON SHAFT

- Do not hammer bearing onto shaft.
- Apply light film of oil on shaft.



③ BOLT HOUSING TO SUPPORT SURFACE

- Bearing and shaft must be in alignment
 - 900 - 1/20° max
 - 950 - 1 1/2° max
 - Ball - 1 1/2° max
- Rotate shaft to make sure it rotates.

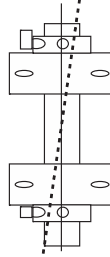

④ FASTEN UNIT TO SHAFT See Torque Specification Tables

- Step 1: Place collar on inner race and rotate by hand in **direction of shaft rotation** until eccentrics are engaged.
- Step 2: Insert drift pin into the hole in the collar O.D. and lock in direction of shaft rotation with the aid of small hammer.
- Step 3: Torque single setscrew to recommended torque - Ref table 22, 23.

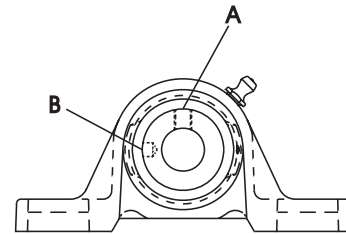

Eccentric Lock Set Screw Tightening Torque

Table 22 Ball Bearings

Bearing Bore (Inches)	Set Screw Diameter	Hex Size Across Flats	Recommended Torque	
			Inch Lbs.	Foot Lbs.
1/2 - 1	1/4-28	1/8	66 - 85	
1 1/8 - 1 1/4	5/16-24	5/32	126 - 164	
1 1/4 - 1 15/16	3/8-24	3/16	228 - 296	19-25
2 - 2 7/16	7/16-20	7/32	348 - 452	29-38
2 11/16 - 2 15/16	1/2-20	1/4	504 - 655	42-55

Table 23 900/950 Tapered Roller

Bearing Bore (Inches)	Set-Screw Diameter (Inches)	Recommended Torque	
		(In-Lbs)	(Ft-Lbs)
1 3/16 to 1 11/16	5/16 - 24	108-140	9-12
1 3/4 to 2 1/2	3/8 - 24	180-230	15-19
2 11/16 to 3 1/2	1/2 - 20	408-530	34-45
3 15/16 to 5	5/8 - 18	876-1000	73-95

- Eccentric Lock not recommended for reversing shaft rotation applications.
- Monitor operating bearing during first 48 hours for unusual vibration or temperatures.

⚠ WARNING
Failure to observe safety precautions could cause personal injury or equipment damage.

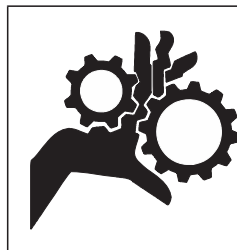

⚠ WARNING
Do not operate without guards. Turn off power to install or service



⚠ CAUTION
High voltage and rotating parts may cause serious or fatal injury. Turn off power to install or service.

Table 24 Ball Bearings

Bore Tolerances For Ball Bearings	
Bore Size (Inches)	Bore Tolerances (Inches)
1/2 to 1 15/16	+0.0006/-0.0000
2 to 3 3/16	+0.0006/-0.0000
3 1/4 to 5	+0.0007/-0.0000

Table 25

Recommended Shaft Tolerances	
Shaft Size (Inches)	Tolerances (Inches)
1/2 to 1 15/16	+0.0000/-0.0005
2 to 3 3/16	+0.0000/-0.0010
3 1/4 to 5	+0.0000/-0.0015

Table 26 920/970 Tapered Roller Bearings

Bore Tolerance	
Bore Size (Inches)	Bore Tolerance (Inches)
1 3/16 to 3	+0.001 / -0.000
3 3/16 to 5	+0.002 / -0.000

Table 27

RECOMMENDED SHAFT TOLERANCES	
Nominal Shaft Size (Inches)	Shaft Tolerances (Inches)
1 3/16 to 1 15/16	+0.0000 / -0.0005
2 to 3 15/16	+0.0000 / -0.0010
4 to 5	+0.0000 / -0.0015

Table 28

HOUSING CAP BOLT TORQUES 970 SERIES PILLOW BLOCKS		
SHAFT SIZE (Inches)	HOUSING CAP BOLT TORQUES	
	(Ft-Lbs)	(In-Lbs)
1 3/8, 1 7/16,	30-35	360-400
1 1/2, 1 11/16,	40-45	465-515
1 3/4, 1 15/16, 2	50-55	615-680
2 3/16	70-75	815-900
2 1/4, 2 7/16, 2 1/2	70-80	860-950
2 11/16, 2 15/16, 3	90-100	1100-1215
3 3/16, 3 7/16, 3 1/2	170-190	2040-2250
3 15/16, 4	265-295	3190-3525
4 7/16, 4 1/2	120-135	1470-1620
4 15/16, 5	195-220	2360-2610

Table 29

HOUSING CAP BOLT TORQUES 970 SERIES FLANGED HOUSINGS		
SHAFT SIZE (Inches)	HOUSING CAP BOLT TORQUES	
	(Ft-Lbs)	(In-Lbs)
1 3/8, 1 7/16,	30-35	365-405
1 1/2, 1 11/16,	40-45	465-515
1 3/4, 1 15/16, 2	50-55	615-680
2 3/16	65-75	810-895
2 1/4, 2 7/16, 2 1/2	70-80	855-945
2 11/16, 2 15/16, 3	90-100	1095-1210
3 3/16, 3 7/16, 3 1/2	170-190	2040-2255
3 15/16, 4	265-295	3190-3530
4 7/16, 4 1/2	325-360	3910-4320
4 15/16, 5	505-560	6065-6705

Table 30 900/950 Tapered Roller Bearings

Bore Tolerance	
Bore Size (Inches)	Bore Tolerance (Inches)
1 to 3 1/2	+0.001 / -0.000
3 15/16 to 5	+0.002 / -0.000

Table 31

RECOMMENDED SHAFT TOLERANCES	
Nominal Shaft Size (Inches)	Shaft Tolerances (Inches)
1 to 1 15/16	+0.0000 / -0.0005
2 to 3 15/16	+0.0000 / -0.0010
4 to 5	+0.0000 / -0.0015

Table 32

HOUSING CAP BOLT TORQUES 950 SERIES PILLOW BLOCKS		
SHAFT SIZE (Inches)	HOUSING CAP BOLT TORQUES	
	(Ft-Lbs)	(In-Lbs)
1 7/16, 1 1/2	30-35	360-400
1 5/8, 1 11/16, 1 3/4	40-45	465-515
1 7/8, 1 15/16, 2, 2 1/8	50-55	615-680
2 3/16	70-75	815-900
2 1/4, 2 7/16, 2 1/2	70-80	860-950
2 11/16, 2 3/4, 2 15/16	90-100	1100-1215
3, 3 3/16	140-150	1680-1800
3 7/16, 3 1/2	170-190	2040-2250
3 15/16, 4	265-295	3190-3525
4 7/16, 4 1/2	120-135	1470-1620
4 15/16, 5	195-220	2360-2610

Table 33

HOUSING CAP BOLT TORQUES 950 SERIES FLANGED HOUSINGS		
SHAFT SIZE (Inches)	HOUSING CAP BOLT TORQUES	
	(Ft-Lbs)	(In-Lbs)
1 7/16, 1 1/2	30-35	365-405
1 5/8, 1 11/16, 1 3/4	40-45	465-515
1 7/8, 1 15/16, 2, 2 1/8	50-55	615-680
2 3/16	65-75	810-895
2 1/4, 2 7/16, 2 1/2	70-80	855-945
2 11/16, 2 3/4, 2 15/16	90-100	1095-1210
3, 3 3/16	140-150	1655-1825
3 7/16, 3 1/2	170-190	2040-2255
3 15/16, 4	265-295	3190-3530
4 7/16, 4 1/2	325-360	3910-4320
4 15/16, 5	505-560	6065-6705

Table 34 1000/1100 Spherical Roller Bearings

Bore Tolerances	
Bore Size (Inches)	Bore Tolerances (Inches)
1 1/8	+0.0005 / +0
1 3/16 to 1 15/16	+0.0006 / +0
2 to 3	+0.0007 / +0
3 3/16 to 4 15/16	+0.0009 / +0

Table 35

Recommended Shaft Tolerances	
Nominal Shaft Size (Inches)	Shaft Tolerances (Inches)
1 1/8 to 1 15/16	+0.0000 / -0.0005
2 to 3 15/16	+0.0000 / -0.0010
4 - 4 15/16	+0.0000 / -0.0015

See page 156 for trademark acknowledgments.

Installation

22200/22500



Mounting the Bearing and Seal Assemblies in the Housing

- Remove the nuts and lockwashers from the housing cap bolts.
- Lift off the cap and remove the stabilizing ring. **CAUTION** Do not mix housing caps and bases. They are machined as a matched set and mixing the cap and bases could result in premature failure.
- Install the outward seal rings on the shaft.
- Clean the housing using an OSHA approved solvent.
- Lift the shaft assembly and place the bearings in the housings, being sure that the seal rings mate with the grooves in the housing.
- Install a stabilizing ring in one bearing housing only, making it non-expansion. Leave out the stabilizing ring for the other bearing, and then center the other bearing in the other housing so that it is free to move in both directions.
- Check the rotation of the shaft. The shaft should rotate freely. Any roughness or binding would indicate an error in assembly and/or dirt in the bearings and should be corrected before operating the bearings.
- Secure the pillow block to the mounting surface by tightening the base bolts. Torque the base bolts to the values recommended by the base bolt supplier.
- Place the corresponding housing caps into position. Tighten the nuts on the cap bolts to the specified values, using the washers included.
- Rotate the shaft again. The shaft should rotate freely.

WARNING The load rating for the 22500 series roller bearing units found in the Browning catalog assume that the bearing unit is base loaded. For any application where there is load carried through the cap of the housing, EPT Mounted Bearing Technical Support (see page 260) should be contacted.

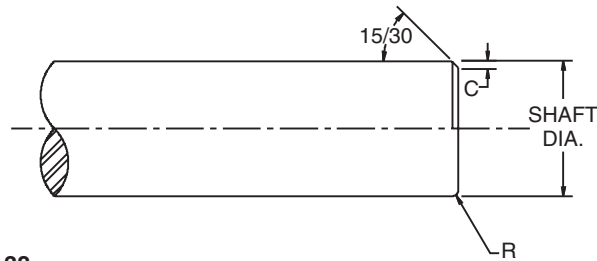

Table 36

Recommended Shaft Tolerance	
Nominal Shaft Size (Inches)	Shaft Tolerance (Inches)
2 7/16 to 2 1/2	+0.00/-0.003
2 9/16 to 4	+0.00/-0.004
4 1/16 to 6	+0.00/-0.005
6 1/16 to 8	+0.00/-0.006

Table 38

Recommended Shaft Tolerance For Taconite Seal				
Shaft Dia. (Inches)	'C' dim. (Inches)	'R' dim. (Inches)	Preferred 'L' @ 15 (Inches)	Preferred 'L' @ 30 (Inches)
2 7/16 to 3 15/16	.093	.188	.313	.156
4 3/16 to 6 15/16	.125	.250	.438	.218
7 3/16 to 7 15/16	.188	.375	.702	.323

Table 37

Recommended Reduction in Internal Clearance (Feeler Gage Method)		
Housing Series	Reduction in Diametrical Clearance	
	Min. (Inches)	Max. (Inches)
515	.0018	.0022
516	.0018	.0022
517	.0018	.0022
518	.0018	.0022
520	.0020	.0025
522	.0020	.0025
524	.0020	.0025
526	.0026	.0032
528	.0026	.0032
530	.0026	.0032
532	.0032	.0040
534	.0032	.0040
536	.0032	.0040
538	.0032	.0040
540	.0032	.0040
544	.0040	.0050

Table 39

Recommended Cap Bolt Torque		
Housing Series	Recommended Cap Bolt Torque (Ft-Lbs)	
	Min.	Max.
515	43	48
516	86	95
517	86	95
518	86	95
520	86	95
522	153	169
524	153	169
526	153	169
528	153	169
530	246	272
532	222	245
534	222	245
536	222	245
538	314	347
540	443	490
544	443	490

Inner Seal Mounting

- Clean the shaft free of burrs. Check that shaft diameter is within specifications.
For Standard Labyrinth Seal: Slide the seal on shaft.
For Taconite Seal Arrangement: Coat the shaft with oil. Make sure that the end of the shaft has the proper chamfer, and slide the V-ring seal on the shaft keeping the lip of the seal towards the bearing. Apply grease to the bore of the Taconite seal assembly. Place the seal in position on the shaft.

22500 Adapter Mounting

- After installing the inner seal, coat the bore and O.D. of the Adapter Sleeve with a light film of oil. Place the adapter sleeve on the shaft at the desired location.
- Measure and record the internal clearance built into the bearing by inserting the feeler gage at the bottom of the bearing between the outer race and a roller. Do not roll over the feeler gage to get a reading, only use a sliding motion on the gage to get a reading.
- Seat the bearing hand tight on the adapter by pushing it up the taper
- Install the locknut, without washer, hand-tight against the bearing.
- Mark the location of the nut with respect to the adapter.
- Tighten the locknut until the measured internal clearance between the bottom of the bearing's outer race and roller is reduced by the amount shown in the table on the following page.
- If the measured reduction in internal clearance exceeds that recommended in the table, rotate the outer race to seat the rollers and remeasure by inserting the feeler gage between the outer race and rollers. If after several tries, you are convinced that the clearance removed in the assembly process is greater than that recommended, back off the locknut and repeat the procedure.
- If the measured reduction in internal clearance is within the recommended specifications, back off the locknut and then securely re-install it with the lockwasher in place.
- Bend the lockwasher tab into the slot in the locknut.

Press Fit Mounting

- After installing the inner seal, fit the bearing on to the shaft.
For smaller bearings, apply a light film of oil or micronized graphite to the shaft and bore of the bearing.
 - Make sure that the bearing is square on the shaft and use either an arbor press or a hammer, in conjunction with a clean pipe pressed against the edge of the inner race, to press the bearing in to place.**For larger bearings,** bring the bearing up to a maximum temperature of 250° F. This may be accomplished by one of the following methods.
 - Place the bearing in an oil bath consisting of either clean oil or a 15% emulsion of oil which is soluble. This should last for 30 minutes to an hour.
 - Place the bearing in a temperature controlled oven for no longer than 4 hours, and preferably only long enough to assist with the size of the bore.
 - Use an induction heater long enough to bring the bore of the bearing up to the necessary size. Once again, make sure that this does not go on for more than 4 hours total time.
(In any case, an open flame should never be used on the bearing.)
 - After getting the bearing bore up to size quickly mount the bearing on the shaft and immediately continue to the following steps.

Installation



Ball Bearing Inserts Spherical O.D.

SPHERICAL OD BEARING INSERT REMOVAL AND REPLACEMENT BALL BEARING UNITS

Ball bearing spherical OD Insert removal and replacement procedure. Browning inserts are selectively fit into castings, therefore Browning recommends replacing the entire housed unit.

REMOVAL:

1 REMOVE BEARING FROM SHAFT

- Loosen set screws.
- Slide bearing off shaft.
- Do not hammer bearing off of shaft.
- Use flat punch to flatten set screw marks



2 ROTATE BEARING

- Rotate bearing 90° relative to housing.
- A lever can be used to aid in the insert removal.

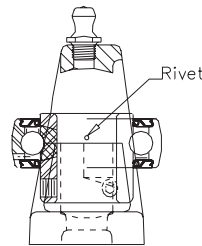

3 REMOVE INSERT

- Push bearing through load slots.

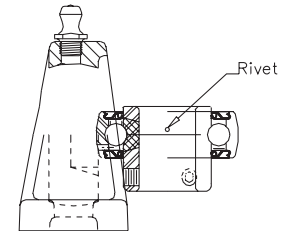

REPLACEMENT:

1 LOAD INSERT

- Clean and Check Bore for Debris.
- Rotate bearing 90° relative to housing.
- With locking side pointed down, push bearing into load slots with rivet in the grease fitting side of housing (Left Hand Side).

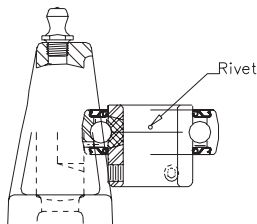

2 ROTATE BEARING

- Rotate bearing back 90° relative to housing.
- Do not hammer bearing into housing.

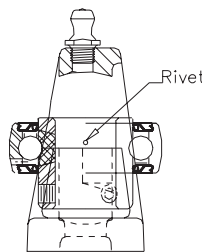

3 ALIGN BEARING WITH HOUSING

- Align insert with housing to assure proper lubrication.

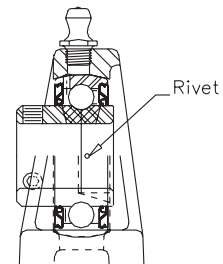

Monitor operating bearing during first 48 hours for unusual vibration or temperatures.

⚠ WARNING
Failure to observe safety precautions could cause personal injury or equipment damage.

⚠ WARNING
Do not operate without guards. Turn off power to install or service

⚠ CAUTION
High voltage and rotating parts may cause serious or fatal injury. Turn off power to install or service.

Tapered Roller Bearings

TAPERED ROLLER INSERT REMOVAL AND REPLACEMENT

950 / 970 tapered roller insert/cartridge removal and replacement procedures.

REMOVAL

1 REMOVE CAP BOLTS

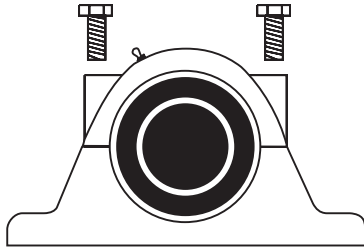

2 REMOVE TOP HALF OF HOUSING

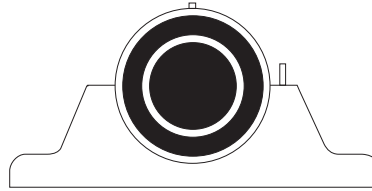

3 REMOVE BEARING FROM SHAFT

- Loosen Set Screws.
- Slide bearing off shaft.
- Do not hammer bearing off of shaft.



REPLACEMENT

1 LOAD NEW INSERT

- Place cartridge into housing.

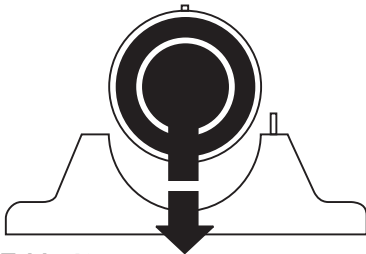

2 REPLACE TOP HOUSING HALF

- Align location pin with location hole.
- Be sure the lock pin is not put into the lubrication hole.

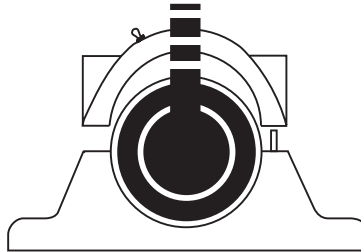

3 REPLACE CAP BOLTS

- Tighten down to recommended torque (Refer to table.)

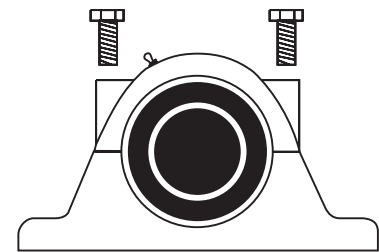

Table 40

Shaft Size (Inches)	Housing Cap Bolt Torques 950 and 970 Series Pillow Blocks	
	(Ft-Lbs)	(In-Lbs)
1 3/8, 1 7/16	30-35	360-400
1 1/2, 1 11/16	40-45	465-515
1 3/4, 1 15/16, 2	50-55	615-680
2 3/16	70-75	815-900
2 1/4, 2 7/16, 2 1/2	70-80	860-950
2 11/16, 2 15/16, 3	90-100	1100-1215
3 3/16, 3 7/16, 3 1/2	170-190	2040-2250
3 15/16, 4	265-295	3190-3525
4 7/16, 4 1/2	120-135	1470-1620
4 15/16, 5	195-220	2360-2610

Table 41

Shaft Size (Inches)	Housing Cap Bolt Torques 950 and 970 Series Flanged Housings	
	(Ft-Lbs)	(In-Lbs)
1 3/8, 1 7/16	30-35	365-405
1 1/2, 1 11/16	40-45	465-515
1 3/4, 1 15/16, 2	50-55	615-680
2 3/16	65-75	810-895
2 1/4, 2 7/16, 2 1/2	70-80	855-945
2 11/16, 2 15/16, 3	90-100	1095-1210
3 3/16, 3 7/16, 3 1/2	170-190	2040-2255
3 15/16, 4	265-295	3190-3530
4 7/16, 4 1/2	325-360	3910-4320
4 15/16, 5	505-560	6065-6705

⚠ WARNING

Failure to observe safety precautions could cause personal injury or equipment damage.



⚠ WARNING

Do not operate without guards. Turn off power to install or service



⚠ CAUTION

High voltage and rotating parts may cause serious or fatal injury. Turn off power to install or service.

Ball Bearing Lubrication

Table 42 Ball Bearing Grease

Thickener	Lithium Complex
Oil	Petroleum
Thickness	NLGI 2
Operating Temperature	-20°F to 200°F Intermittent to 250°F

Consult EPT Mounted Bearing Tech Support for current grease specification.

Grease compatibility is critical. Relubricate with a grease that is compatible with grease supplied from the factory. Consult your grease supplier for compatibility.

Frequency of Lubrication

The tables below state general lubrication recommendations based on our experience and are intended as suggested or starting points only. For best results, specific applications should be monitored regularly and lubrication intervals and amounts adjusted accordingly.

Table 43 Ball Bearings

Speed	Temperature	Cleanliness	Greasing Interval
100 RPM	-20°F to 125°F	Clean	4-10 months
500 RPM	-20°F to 150°F	Clean	1-4 months
1000 RPM	-20°F to 200°F	Clean	1 week to 1 month
1500 RPM	-20°F to 200°F	Clean	Biweekly
1500 to Maximum Catalog Rating	Up to 150°F	Dirty	Daily to 1 week
	150°F to 200°F	Dirty	Daily to 1 week
	-20°F to 200°F	Very Dirty	Daily to 1 week
	-20°F to 200°F	Extreme Conditions	Daily to 1 week

Table 44 Ball Bearings

Ball Bearings	
Shaft Size (Inches)	Grease Charge (Ounces)
1/2 to 1	0.03
1 1/16 to 1 3/16	0.10
1 1/4 to 1 1/2	0.15
1 11/16 to 1 15/16	0.20
2 to 2 7/16	0.30
2 1/2 to 2 15/16	0.50
3 to 3 7/16	0.85
3 1/2 to 4	1.50

Tapered Roller Bearing Lubrication

Table 45 Tapered Roller Bearing Grease

Thickener	Lithium 12 Hydroxy Stearate
Oil	Petroleum
Thickness	NLGI 2
Operating Temperature	-20°F to 200°F Intermittent to 250°F
EP Additive	Yes

Consult EPT Mounted Bearing Tech Support for current grease specification.

Grease compatibility is critical. Relubricate with a grease that is compatible with grease supplied from the factory. Consult your grease supplier for compatibility.

Frequency of Lubrication

The tables below state general lubrication recommendations based on our experience and are intended as suggested or starting points only. For best results, specific applications should be monitored regularly and lubrication intervals and amounts adjusted accordingly.

Table 46 Tapered Roller Bearings

Speed	Temperature	Cleanliness	Greasing Interval
100 RPM	-20°F to 125°F	Clean	1-4 months
500 RPM	-20°F to 150°F	Clean	1 week to 1 month
1000 RPM	-20°F to 210°F	Clean	1-2 weeks
1500 to Maximum Catalog Rating	-20°F to 150°F	Dirty	Daily to 1 week
	150°F to 200°F	Dirty	Daily to 1 week
	-20°F to 200°F	Very Dirty *	Daily to 1 week
	-20°F to 200°F	Extreme Conditions *	Daily to 1 week

Table 47 920/970 Tapered Roller Bearings

Spherical Roller Bearings	
Shaft Size (Inches)	Grease Charge (Ounces)
1 3/16 to 1 1/4	0.10
1 3/8 to 1 7/16	0.22
1 1/2 to 1 11/16	0.32
1 3/4 to 2	0.50
2 to 2 3/16	0.55
2 1/4 to 2 1/2	0.65
2 11/16 to 3	0.85
3 3/16 to 3 1/2	1.25
3 15/16 to 4	2.50
4 7/16 to 4 1/2	3.10

900/950 Series Tapered Roller Bearings

900 and 950 Series tapered roller bearings utilize a labyrinth seal design which requires frequent relubrication to maintain maximum effectiveness. Grease should be added to fully purge and fill the grease cavity.

In dry, contaminated environments, daily relubrication is required for 900 and 950 series bearings. For moist, wet or contaminated environments consider 920 or 970 Series products.*

Lubrication

Spherical Roller Bearings



Spherical Roller Bearing Lubrication

Table 48 Tapered Roller Bearing Grease

Thickener	Lithium 12 Hydroxy Stearate
Oil	Petroleum
Thickness	NLGI 2
Operating Temperature	-20°F to 200°F Intermittent to 250°F
EP Additive	Yes

Consult EPT Mounted Bearing Tech Support for current grease specifications.

Grease compatibility is critical. Relubricate with a grease that is compatible with grease supplied from the factory. Consult your grease supplier for compatibility.

Frequency of Lubrication

The tables below state general lubrication recommendations based on our experience and are intended as suggested or starting points only. For best results, specific applications should be monitored regularly and lubrication intervals and amounts adjusted accordingly.

Table 49 Spherical Roller Bearings

Speed	Temperature	Cleanliness	Greasing Interval
100 RPM	-20°F to 125°F	Clean	1-4 months
500 RPM	-20°F to 150°F	Clean	1 week to 1 month
1000 RPM	-20°F to 210°F	Clean	1-2 weeks
1500 to Maximum Catalog Rating	Up to 150°F	Dirty	Daily to 1 week
	Over 150°F	Dirty	Daily to 1 week
	Up to 250°F	Very Dirty *	Daily to 1 week
	Up to 250°F	Extreme Conditions *	Daily to 1 week

Table 50 Spherical Roller Bearings w/Contact Seal

Spherical Roller Bearings	
Shaft Size (Inches)	Grease Charge (Ounces)
1 3/16 to 1 1/4	0.10
1 3/8 to 1 7/16	0.22
1 1/2 to 1 11/16	0.32
1 3/4 to 2	0.50
2 to 2 3/16	0.55
2 1/4 to 2 1/2	0.65
2 11/16 to 3	0.85
3 3/16 to 3 1/2	1.25
3 15/16 to 4	2.50
4 7/16 to 4 1/2	3.10
4 15/16 to 5	4.75

Spherical Roller Bearings w/Labyrinth Seals

1000 and 1100 series spherical roller bearings utilize a labyrinth seal design which requires frequent relubrication to maintain maximum effectiveness. Therefore, grease should be added to fully purge and fill the seal cavity.

In dry, contaminated environments, daily relubrication is required. For moist, wet or contaminated environments consider Contact Seal.*

Fittings and Adapters

Table 51 Ball Bearings Units

BEARING UNIT SERIES	SHAFT SIZE			
	1/2 to 1 1/4S	1 1/4 to 2 15/16	1	1 3/16 to 3 15/16
VF2B - 200	1641B	1610B		
VF2B - 300			1641B	1610B
VF2E - 100, 200	1641B	1610B		
VF2E - 100M	1641B	1641B		
VF2S - 100, 200	1641B	1610B		
VF2S - 300			1641B	1610B
VF2S - 100M	1641B	1641B		
VF3E - 100M	1641B	1641B		
VF3S - 100M	1641B	1641B		
VF4B - 200	1641B	1610B		
VF4B - 300			1641B	1610B
VF4E - 100, 200	1641B	1610B		
VF4S - 100, 200	1641B	1610B		
VF4S - 300			1641B	1610B
VFCB - 200	1641B (to 2 3/16)	1610B (2 1/4 up)		
VFCB - 300			1641B	1610B
VFCS - 200	1641B (to 2S)	1610B (2 up)		
VFCS - 300			1641B (to 2)	1610B (2 3/16 up)
VPE - 100, 200	1641B	1610B		
VPE - 100M	1641B	1641B		
VPLB - 200	1641B	1610B		
VPLE - 100, 200	1641B	1610B		
VPLS - 100, 200	1641B	1610B		
VPB - 200	1641B	1610B		
VPB - 300			1641B	1610B
VPS - 100, 200	1641B	1610B		
VPS - 300			1641B	1610B
VPS - 100M	1641B	1641B		
VTBE - 200	1641B	1610B		
VTBE - 100	1641B	1610B		
VTBS - 100, 200	1641B	1610B		
VTWE - 100, 200	1911B	1613B		
VTWS - 100, 200	1911B	1613B		
VTWS - 300			1911B	1613B

Table 52 Tapered Roller and Spherical Roller Bearings Units

900	1610B - All PB, FB, FC	1612B - All TU
920	1610B - All PBE, FBE	1613B - All TUE
950	1610B - All	
970	1610B - All	
1000 - Thru 4"	1610B - All SPB, SFB	1641B - All SFC
SPB1000F - 4 7/16 - 4 1 5/16	1627B - 1/4 PTF	
1100	1610B - All	
22200	PLUGGED	
22500	PLUGGED	

See page 156 for trademark acknowledgments.

Browning Fittings/Adapters

Table 53

Fitting Or Adapter		Fitting Or Adapter		Fitting	Fitting	Fitting
1641B 1/4-28 NF	51942 1/4-28 Male NF to 1/8 NPT Fem	1610B 1/8 NPT THD	43761 1/8 NPT Male to 1/8 NPT Fem	1911b 1/4-28 NF	1613B 1/8 PTF	1612B 1/8 PTF

1641B

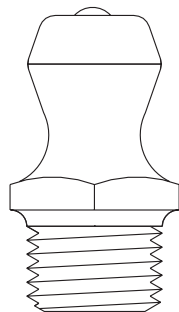

1/4-28 NF

Or

51942

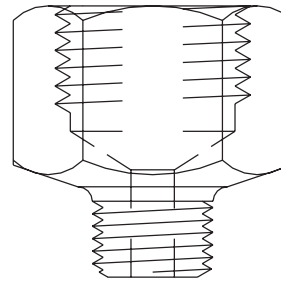

1/4-28 Male NF to
1/8 NPT Female

1610B

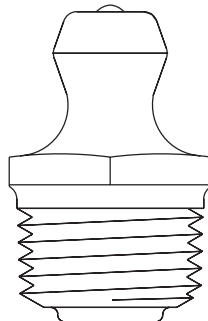

1/8 NPT THD

Or

43761

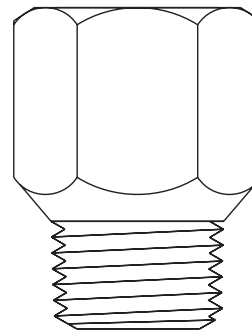

1/8 NPT Male to
1/8 NPT Female

1911B

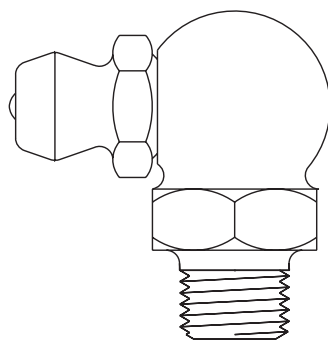

1/4-28 NF

1631B

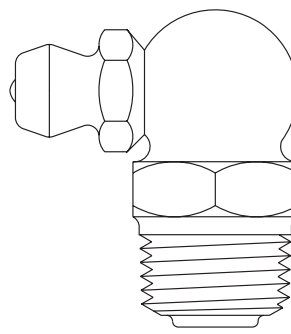

1/8 PTF

1612B

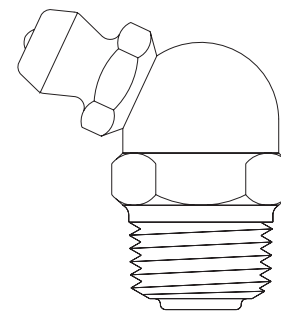

1/8 PTF

Browning Ball Bearings - Vibration Analysis

The following is the procedure to be followed in calculating the fundamental frequencies for Browning ball bearings.

1. If the Browning insert number is known, proceed to step 2. For housed units, identify the bearing insert number by looking up the unit in the Browning Catalog, then proceed to step 2.
2. Find your Browning insert number in Table 54 below and identify the series.
3. Select the vibration geometry information (O, I, B, F) from Table 54 based on bearing series.
4. Use this information to calculate the fundamental bearing frequencies by multiplying the factor in Table 55 by the shaft speed (in RPM).

$$\begin{aligned} \text{Outer Ball Pass Freq. (Hz)} &= O \times \text{RPM} \\ \text{Inner Ball Pass Freq. (Hz)} &= I \times \text{RPM} \\ \text{Ball Spin Freq. (Hz)} &= B \times \text{RPM} \\ \text{Fundamental Train Freq. (Hz)} &= F \times \text{RPM} \end{aligned}$$

TABLE 54 BROWNING INSERT SERIES

SERIES	VALULINE INSERT							
	X-108	X-110	X-208	X-210				
L-10	X-108	X-110	X-208	X-210				
2-012	X-112	X-212						
2-015	X-114	X-115	X-116	X-214	X-215	X-216		
2-13	X-118	X-119	X-120S	X-218	X-219	X-220S	X-316	
2-17	X-120	X-122	X-123	X-220	X-222	X-223	X-319	X-320
2-19	X-124	X-224	X-323					
2-111	X-126	X-127	X-128	X-226	X-227	X-228	X-324	
2-115	X-130	X-131	X-132S	X-230	X-231	X-232S	X-327	X-328
2-23	X-132	X-134	X-135	X-232	X-234	X-235	X-331	X-332
2-27	X-236	X-239	X-335	X-336				
2-211	X-240	X-243	X-339	X-340				
2-215	X-247	X-343						
2-33	X-347	X-348						
2-38	X-355	X-356						
2-43	X-363							

Where X denotes one of: LE, LS, RUBRE, RUBRS, SLE, LRE, LRS, SLS, VB, VE, VER, VS,

Vibration Analysis

Ball Bearings



Browning Ball Bearings - Vibration Analysis

TABLE 55 VIBRATION INFORMATION

SERIES	Pitch Diameter (in) dM	Number of Balls N	Ball Diameter (in) D	Factor For Outer Ball Pass O	Factor For Inner Ball Pass I	Factor For Ball Spin B	Factor For Fund. Train F
L-10	1.138	9	1/4	0.0585	0.0915	0.0361	0.0065
2-012	1.345	9	9/32	0.0593	0.0907	0.0381	0.0066
2-015	1.544	10	9/32	0.0682	0.0985	0.0442	0.0068
2-13	1.812	9	3/8	0.0595	0.0905	0.0385	0.0066
2-17	2.115	9	7/16	0.0595	0.0905	0.0386	0.0066
2-19	2.362	9	1/2	0.0591	0.0909	0.0376	0.0066
2-111	2.596	10	1/2	0.0673	0.0994	0.0417	0.0067
2-115	2.763	10	1/2	0.0683	0.0984	0.0445	0.0068
2-23	3.051	10	9/16	0.0680	0.0987	0.0437	0.0068
2-27	3.356	10	5/8	0.0678	0.0989	0.0432	0.0068
2-211	3.846	10	11/16	0.0684	0.0982	0.0451	0.0068
2-215	4.045	11	11/16	0.0761	0.1072	0.0476	0.0069
2-33	4.362	11	3/4	0.0759	0.1074	0.0470	0.0069
2-37	4.627	11	25/32	0.0762	0.1071	0.0479	0.0069
2-38	4.922	10	7/8	0.0685	0.0981	0.0454	0.0069
2-43	5.808	10	1-1/16	0.0681	0.0986	0.0440	0.0068

Browning 900 & 950 Tapered Roller Bearings - Vibration Analysis

The following is the procedure which should be followed in calculating the fundamental frequencies for Browning 900 and 950 tapered roller bearings.

1. The bore size for each bearing to be analyzed must be known.
2. Once the bore size is known the appropriate vibration factors (O,I,B and F) can be chosen from Table 56.
3. These factors can then be used to calculate the fundamental bearing frequencies as follows:

$$\begin{aligned} \text{Roller Spin Frequency (Hz)} &= O \times \text{RPM} \\ \text{Inner Race Pass Frequency (Hz)} &= I \times \text{RPM} \\ \text{Outer Race Pass Frequency (Hz)} &= B \times \text{RPM} \\ \text{Fundamental Train Frequency (Hz)} &= F \times \text{RPM} \end{aligned}$$

Table 56 Vibration information

SHAFT SIZE (INCHES)	FACTOR FOR ROLLER SPIN O	FACTOR FOR INNER ROLLER PASS I	FACTOR FOR OUTER ROLLER PASS B	FACTOR FOR FUND. TRAIN F
1	0.1197	0.1794	0.1373	0.0072
1 3/16 1 1/4 1 3/8	0.1136	0.1616	0.1218	0.0072
1 7/16 1 1/2	0.1195	0.1795	0.1372	0.0072
1 5/8 1 11/16 1 3/4	0.1284	0.1873	0.1460	0.0073
1 7/8 1 15/16 2 2 1/8	0.1216	0.1792	0.1375	0.0072
2 3/16	0.1345	0.1958	0.1542	0.0073
2 1/4 2 7/16 2 1/2	0.1397	0.2043	0.1623	0.0074
2 11/16 2 3/4 2 15/16	0.1578	0.2202	0.1798	0.0075
3 3 3/16	0.1535	0.2116	0.1718	0.0075
3 7/16 3 1/2	0.1706	0.2368	0.1966	0.0076
3 15/16 4	0.2258	0.3035	0.2631	0.0077
4 7/16 4 1/2	0.2204	0.2953	0.2547	0.0077
4 15/16 5	0.2324	0.3210	0.2790	0.0078

Vibration Analysis

Tapered Roller Bearings



Browning 920 & 970 Series Tapered Roller Bearings - Vibration Analysis

The following is the procedure which should be followed in calculating the fundamental frequencies for Browning 920 and 970 tapered roller bearings.

1. The bore size for each bearing to be analyzed must be known.
2. Once the bore size is known the appropriate vibration factors (O,I,B, and F) can be chosen from Table 57.
3. These factors can then be used to calculate the fundamental bearing frequencies as follows:

$$\begin{aligned}
 \text{Roller Spin Frequency (Hz)} &= O \times \text{RPM} \\
 \text{Inner Race Pass Frequency (Hz)} &= I \times \text{RPM} \\
 \text{Outer Race Pass Frequency (Hz)} &= B \times \text{RPM} \\
 \text{Fundamental Train Frequency (Hz)} &= F \times \text{RPM} \quad \text{- shaft rotation}
 \end{aligned}$$

Table 57 Vibration Information

SHAFT SIZE (INCHES)	FACTOR FOR ROLLER SPIN O	FACTOR FOR INNER ROLLER PASS I	FACTOR FOR OUTER ROLLER PASS B	FACTOR FOR FUND. TRAIN F
1 3/16 1 1/4	0.1258	0.1782	0.1384	0.0073
1 3/8 1 7/16	0.1173	0.1892	0.0442	0.0072
1 1/2 1 11/16	0.1132	0.1710	0.1290	0.0072
1 3/4 1 15/16 2	0.1083	0.1626	0.1207	0.0071
2 3/16 2 1/4 2 7/16 2 1/2	0.1216	0.1792	0.1375	0.0072
2 11/16 2 15/16 3	0.1345	0.1958	0.1542	0.0073
3 3/16 3 7/16 3 1/2	0.1578	0.2202	0.1798	0.0075
3 15/16 4	0.1706	0.2368	0.1966	0.0076
4 7/16 4 1/2	0.1645	0.2376	0.1958	0.0075
4 15/16 5	0.1600	0.2289	0.1878	0.0075
	0.1587	0.2292	0.1875	0.0075

Browning 1000/1100 Series Spherical Roller Bearings - Vibration Analysis

The following is the procedure which should be followed in calculating the fundamental frequencies for Browning 1000/1100 spherical roller bearings.

1. The bore size for each bearing to be analyzed must be known.
2. Once the bore size is known the appropriate vibration factors (O,I,B, and F) can be chosen from Table 58.
3. These factors can then be used to calculate the fundamental bearing frequencies as follows:

Roller Spin Frequency (Hz)	= O x RPM	
Inner Race Pass Frequency (Hz)	= I x RPM	
Outer Race Pass Frequency (Hz)	= B x RPM	
Fundamental Train Frequency (Hz)	= F x RPM	- shaft rotation

Table 58 Vibration Information

SHAFT SIZE (INCHES)	FACTOR FOR ROLLER SPIN O	FACTOR FOR INNER ROLLER PASS I	FACTOR FOR OUTER ROLLER PASS B	FACTOR FOR FUND. TRAIN F
1 1/8 1 3/16 1 1/4 1 7/16 1 1/2	0.0989	0.1548	0.1118	0.0070
1 11/16 1 3/4	0.1075	0.1628	0.1205	0.0071
1 15/16 2	0.1161	0.1803	0.1363	0.0072
2 3/16	0.1114	0.1717	0.1283	0.0071
2 7/16 2 1/2	0.1140	0.1807	0.1360	0.0072
2 11/16 2 3/4 2 15/16 3	0.1268	0.1974	0.1526	0.0073
3 3/16 3 7/16 3 1/2	0.1213	0.1889	0.1444	0.0072
3 11/16 3 15/16 4	0.1185	0.1799	0.1367	0.0072
4 7/16 4 15/16	0.1162 0.1186	0.1803 0.1798	0.1364 0.1368	0.0072 0.0072

Vibration Analysis

Spherical Roller Bearings



Browning 22500 Series Spherical Roller Bearings - Vibration Analysis

The following is the procedure which should be followed in calculating the fundamental frequencies for Browning 22500 series spherical roller bearings.

1. The bore size for each bearing to be analyzed must be known.
2. Once the bore size is known the appropriate vibration factors (O,I,B and F) can be chosen from Table 59.
3. These factors can then be used to calculate the fundamental bearing frequencies as follows:

$$\begin{aligned}
 \text{Roller Spin Frequency (Hz)} &= O \times \text{RPM} \\
 \text{Inner Race Pass Frequency (Hz)} &= I \times \text{RPM} \\
 \text{Outer Race Pass Frequency (Hz)} &= B \times \text{RPM} \\
 \text{Fundamental Train Frequency (Hz)} &= F \times \text{RPM} \quad \text{- shaft rotation}
 \end{aligned}$$

Table 59 Vibration Information

SHAFT SIZE (INCHES)	FACTOR FOR ROLLER SPIN O	FACTOR FOR INNER ROLLER PASS I	FACTOR FOR OUTER ROLLER PASS B	FACTOR FOR FUND. TRAIN F
2 7/16" 2 1/2"	0.1268	0.1786	0.1381	0.0073
2 11/16" 2 3/4"	0.1253	0.1788	0.1378	0.0073
2 15/16" 3"	0.1209	0.1701	0.1299	0.0072
3 3/16"	0.1213	0.17	0.13	0.0072
3 7/16" 3 1/2"	0.1185	0.1799	0.1366	0.0072
3 11/16" 3 15/16" 4"	0.1162	0.1803	0.1364	0.0072
4 3/16"	0.1173	0.1801	0.1366	0.0072
4 7/16" 4 1/2"	0.1186	0.1798	0.1368	0.0072
4 15/16" 5"	0.1189	0.1798	0.1369	0.0072
5 3/16"	0.1154	0.1804	0.1362	0.0072
5 7/16" 5 1/2"	0.1157	0.1804	0.1363	0.0072
5 15/16" 6"	0.1155	0.1804	0.1363	0.0072
6 7/16" 6 1/2"	0.1194	0.1892	0.1442	0.0072
6 15/16" 7"	0.1180	0.1800	0.1367	0.0072
7 3/16"	0.1155	0.1804	0.1363	0.0072
7 1/2" 7 15/16" 8"	0.1155	0.1803	0.1364	0.0072

Browning®

Index

BALL BEARINGS

SET SCREW	4
AIR HANDLING	50
BOA™	52
ECCENTRIC	70

TAPERED ROLLER BEARINGS

900	103
E920	103
950	116
970	116

SPHERICAL ROLLER BEARINGS

1000	128
1100	128
22500	140
22200	140

INTERCHANGES

HEAD TO HEAD OVERVIEWS	156
BALL AND ROLLER ALPHA-NUMERIC	166

ENGINEERING

260

PRODUCTS

12SF	15
12TF	15
18SF	15
18TF	15
1SF	15
22200CKW33C3	147
22200CW33C3	149
3SF	15
6SF	15
6TF	15
9SF	15
9TF	15
ANW	150
C950	120
C970	124
EC	151
FB900	105
FB950E	119
FB950NE	119
FB970E	123
FB970NE	123
FBE920	111
FC900	106
LE-100	97
LRS-100	45
LS-100	48
PB900	104
PB950E	118
PB950FE	118
PB950FNE	118
PB950NE	118
PB970E	122
PB970FE	122
PB970FNE	122
PB970NE	122
PBE920	110
PBE920F	110
RUBRE-100	95
RUBRS-100	43
SFB1000NE-3	131
SFB1000NEC-3	131
SFB1000NEC	130

SFB1100E	137
SFB1100EC	137
SFB1100NE	137
SFB1100NEC	137
SFC1000E	134
SFC1000EC	134
SFC1000NE	134
SFC1000NEC	134
SFC1100E	138
SFC1100EC	138
SFC1100NE	138
SFC1100NEC	138
SLE-100	96
SLS-100	44
SNW	148
SPB1000E	128
SPB1000EC	128
SPB1000FE	129
SPB1000FEC	129
SPB1000FNE	129
SPB1000FNEC	129
SPB1000NE	128
SPB1000NEC	128
SPB1100E	136
SPB1100EC	136
SPB1100NE	136
SPB1100NEC	136
SPBF22200	145
SPBF22500	143
SPBF22500XTC	152
SPBF22500XTE	152
SPBFS22200	146
SPBT22200	145
SPBT22500	142
SPBT22500XEC	151
SPBT22500XTC	152
SPBT22500XTE	152
SPBTS22200	146
SPBTS22500	144
SSF2E-100	91
SSF2S-100	39
SSF3E-100	92
SSF3S-100	40
SSF3TE-100	94
SSF3TS-100	42
SSF4E-100	93
SSF4S-100	41
SSPE-100	90
SSPS-100	38
SSRPE-100	89
SSRPS-100	37
STU1000NE	132
STU1000NEC	132
T1000	113
T1000	133
T2000-2	153
T2000-4	154
T900	109
TU900	108
TUE920	112
VB-200	72
VB-300	68
VE-100	98
VE-200	78
VER-200	16
VF2B-200	56

VF2B-300	65
VF2E-100	82
VF2E-100M	86
VF2E-200	74
VF2S-100	30
VF2S-100M	34
VF2S-200	8
VF2S-200 AH	8
VF2S-200 NK	8
VF2S-300	21
VF2S-300 AH	21
VF3E-100M	88
VF3S-100M	36
VF4B-200	57
VF4B-300	66
VF4E-100	83
VF4E-200	75
VF4S-100	31
VF4S-200	9
VF4S-200	22
VF4S-200 AH	9
VF4S-200 AH	22
VF4S-200 NK	9
VFBB-200	59
VFBS-200	11
VFCB-200	61
VFCB-300	67
VFCS-200	10
VFCS-300	23
VPB-200	54
VPB-200 AH	54
VPB-300	64
VPB-300 AH	64
VPE-100	80
VPE-100M	87
VPE-200	72
VPE-200 NK	72
VPLB-200	55
VPLE-100	81
VPLE-200	73
VPLE-200 AH	73
VPLE-200 NK	73
VPLS-100	29
VPLS-200	7
VPLS-200 AH	7
VPLS-200 NK	7
VPS-100	28
VPS-100M	35
VPS-200	6
VPS-200 AH	6
VPS-200 NK	6
VPS-300	20
VPS-300 AH	20
VS-100	47
VS-200	18
VS-300	26
VTBB-200	58
VTBE-100	84
VTBS-200	13
VTBS-200 NK	13
VTWE-100	85
VTWE-200	76
VTWS-100	32
VTWS-200	14
VTWS-200 NK	14
VTWS-300	24

See page 156 for trademark acknowledgments.



BROWNING® MOUNTED BALL BEARINGS...

Are segmented into three series ranging from intermediate duty for lightly loaded applications to medium duty for heavier loads:

100 = Intermediate Duty, **200** = Normal Duty, **300** = Medium Duty

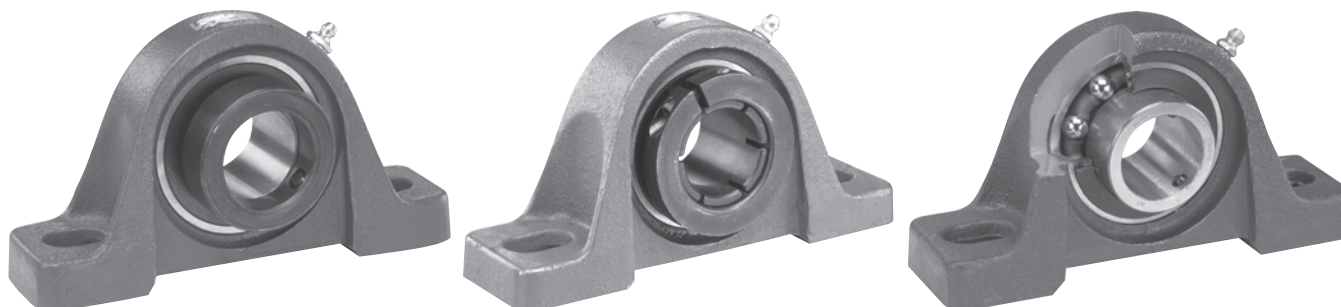

BALL BEARING UNITS

Series	Locking	Available Options				Bore Size			
		AH	NK	SS	D	Pillow Blocks (High, Low & Tapped Base)	Flange Blocks (2, 3, 4 Bolt)	Flange Cartridges	Take-Up Units
100	Set Screw			✓	✓	1/2" - 2 3/16"	1/2" - 2 3/16"	N/A	3/4" - 2 3/16"
	Eccentric			✓	✓	1/2" - 2 3/16"	1/2" - 2 3/16"	N/A	1/2" - 2 3/16"
200	Set Screw	⊗	Ⓝ			1/2" - 2 15/16"	1/2" - 2 15/16"	1 1/8" - 2 11/16"	1/2" - 2 7/16"
	Eccentric	⊗				1/2" - 2 15/16"	1/2" - 2 15/16"	N/A	3/4" - 2 7/16"
	BOA	⊗				3/4" - 2 7/16"	3/4" - 2 7/16"	1 1/8" - 2 7/16"	N/A
300	Set Screw	⊗				1" - 3 15/16"	1" - 3 15/16"	1" - 3 15/16"	1" - 3"
	BOA	⊗				1" - 2 3/16"	1" - 2 3/16"	1" - 2 3/16"	N/A

AH = Air Handling NK = Nickel Plating SS = Stamped Steel Housing D = Ductile Iron Housing

Corrosion Resistant Mounted Ball Bearings...



CRES stands for **Corrosion Resistant Engineered Solutions**... a new look at corrosion resistant power transmission components. CRES Mounted Ball Bearing products start with the latest in corrosion resistance technology coupled with advanced industry-minded features driven by industry-focused leaders. Our engineers designed CRES around the notion that a "family" of corrosion resistant products spanning the spectrum of performance and value will provide customers flexibility and latitude to specify the correct solution when and where they see fit.



CRES CZ

Composite housing & zinc coated insert

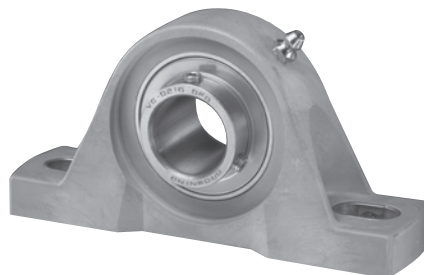

CRES CS

Composite housing & 400 series stainless steel insert

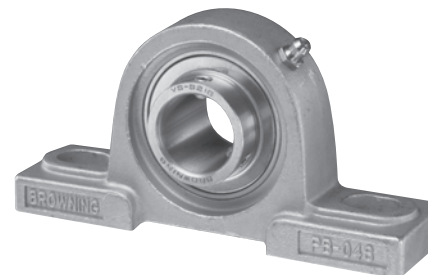

CRES SS

300 series stainless steel housing & 400 series stainless steel insert

CORROSION RESISTANT MOUNTED BALL BEARINGS

Series	Type Locking	Bore Sizes			Housing Material
		Pillow Blocks	Flange 2 & 4 Bolt	Tapped Base	
CRES CZ	Setscrew	3/4" - 1 1/2"	3/4" - 1 1/2"	3/4" - 1 1/2"	Composite
CRES CS	Setscrew	3/4" - 1 1/2"	3/4" - 1 1/2"	3/4" - 1 1/2"	Composite
CRES SS	Setscrew	3/4" - 1 1/2"	3/4" - 1 1/2"	3/4" - 1 1/2"	300 Series Stainless Steel

BROWNING BEARING TECHNOLOGY PAYS OFF WHERE IT COUNTS MOST...

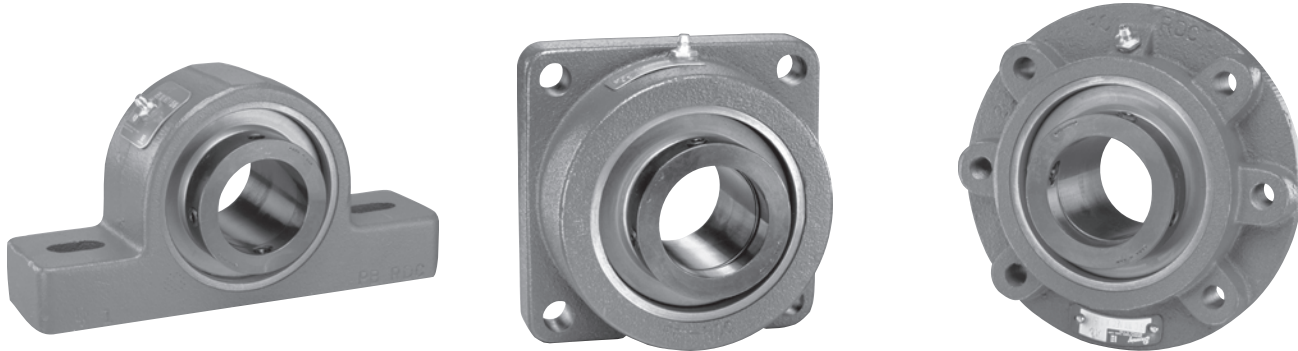

1100 Pillow Blocks... 1100 Series Pillow Blocks have a solid base beneath the bolt holes and thicker mounting feet.

1100 Four Bolt Flanges... 1100 Series Square Four Bolt Flange design contains more material to withstand shock loads and vibration normally found in sawmill applications.

1100 Flange Cartridges... 1100 Series Flange Cartridges have thicker bolt hole mounting pads. Withdrawal holes in the housing help remove the units from their mounting structure during replacement.

TAPERED ROLLER BEARINGS

Series	Locking	Features				Bore Size			
		E	SA	SH	D	Pillow Blocks (2 & 4 Bolt)	Flange Blocks (4 Bolt)	Flange Cartridges	Take-Up Units
900	Eccentric				✓	1" - 5"	1" - 4 1/2"	1" - 3 1/2"	1 7/8" - 4"
E920	Set Screw					1 3/16" - 5"	1 3/16" - 4"	N/A	1 3/8" - 4 7/16"
950	Eccentric	✓	✓	✓	✓	1 7/16" - 5"	1 7/16" - 5"	N/A	N/A
970	Set Screw	✓	✓	✓	✓	1 3/8" - 5"	1 3/8" - 5"	N/A	N/A

E = Expansion Available SA = Self Aligning SH = Split Housing D = Ductile Iron Housing

SPHERICAL ROLLER BEARINGS

Series	Locking	Features					Bore Size			
		E	SA	SH	CI	D	Pillow Blocks (2 & 4 Bolt)	Flange Blocks (3 & 4 Bolt)	Flange Cartridges	Take-Up Units
1000	Set Screw	✓	✓		✓		1" - 5"	1 3/8" - 4"	1 7/16" - 4"	1 15/16" - 4"
1100	Set Screw	✓	✓			✓	1 15/16" - 3 1/2"	1 15/16" - 3 1/2"	1 15/16" - 4"	N/A
22200	Cylindrical	✓	✓	✓		*	3" - 8 5/16"	N/A	N/A	N/A
22500	Adapter	✓	✓	✓		*	2 7/16" - 8"	N/A	N/A	N/A

E = Expansion Available SA = Self Aligning SH = Split Housing CI = Cast Iron D = Ductile Iron Housing
*Cast Steel Housing Available

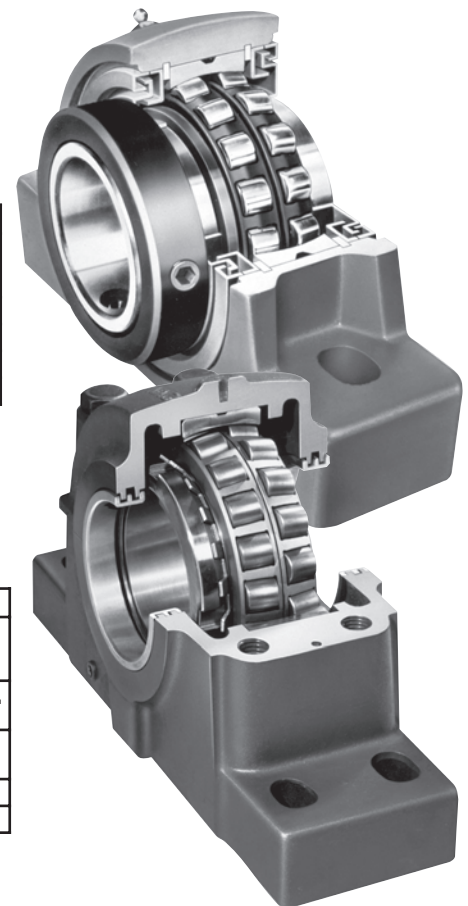



**A COMPLETE SELECTION OF BROWNING PRODUCTS
LEADS TO THE RIGHT V-BELT FOR EVERY APPLICATION**

The extensive BROWNING V-drive line means maximum economy, versatility and prompt availability for your every application — truly the *right drive every time...for every service*

BROWNING B5V®... The most significant advance in belt drives since the V-groove!

With the introduction of the revolutionary B5V line, BROWNING brings up-to-the-minute technology to drive design, operation and inventory control. Now — more than ever — when you specify BROWNING, you select from the most extensive V-belt drive line in the world.

- **New combination groove B5V®** - with 170 plus components covering 10-125 HP range. Mix and match with conventional A, B and 5V components



CLASSICAL GRIPBELT® SHEAVES -- BUSHING TYPE

Belt Size	Sheave	Grooves	DD/PD*	Bore Range
A	AKH	1-2	2.8-18.0	1/2"-1 1/2"
	AK**	1-2	1.8-18.0	3/8-1 7/16
	TA	1-4	3.0-24.5	1/2-2 11/16
A-B	BKH	1-3	2.8-18.4	1/2-1 1/2
	BK**	1-3	2.2-18.4	3/8-1 7/16
	TB	1-6	A-3.0-37.5	1/2-2 11/16
		B	2-10	A-5.0-37.5 B-3.4-38.0 B-5.4-38.0
A-B-5V	B5V	1-6	A-3.8-27.3 B-4.2-27.8 5V-4.3-27.5	1/2-2 7/16
C	TC	1-6	7.0-24.0	3/4-2 11/16
		1-12	5.6-50.0	1/2-5
D	D	4-12	12.0-48.0	1 3/8-5
"358" GRIPBELT® SHEAVES				
3V	3V	1-10	2.6-33.45	3/8-4 1/4
	3V**	1-4	2.6-3.3	5/8-1 3/8
5V	5V	1-10	4.3-49.9	1/2-5
8V	8V	4-16	12.3-63.8	1 11/16-7 7/16

* Datum Dia. for A-B-C-D, Pitch Dia. for "358".
** Finished Bore Type.

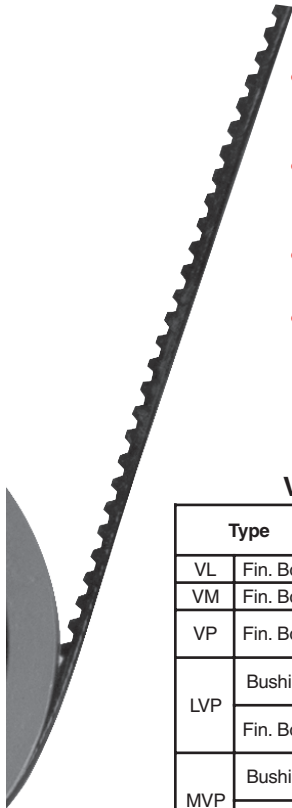

- **Multiple groove sheaves** available in over 2100 stock sizes, far more than from any other manufacturer
- **Cast iron sheaves** - Over 3000 AK/BK size and bore combinations in stock, in-shaft ready bushing type and finished bore
- **"358" Sheaves** stocked in a range of fixed and variable pitch sizes
- **Variable speed sheaves** through 750 HP, precision balanced to provide smooth vibration-free performance

VARIABLE SPEED SHEAVES

Type	Groove	Belt	DD/PD	Bore Range	
VL Fin. Bore	1	3L, 4L/A, 5L/B	1.6-3.8	1/2-7/8"	
VM Fin. Bore	1	3L, 4L/A, 5L/B	1.9-4.7	1/2-7/8"	
VP Fin. Bore	1-2	3L, 4L/A, 5L/B, 5V	1.4-7.4	1/2-1 5/8"	
LVP	Bushing	1-2	A, B, 5V	4.2-8.4	1/2-1 3/4"
	Fin. Bore	1-2	A, B, 5V	3.4-8.4	7/8-1 7/8"
MVP	Bushing	2-6	A, B, C, 5V	5.9-12.5	3/4-2 5/8"
	Fin. Bore	3-10	A, B, C, 5V, 8V	3.4-17.2	7/8-4 3/4"

COMPANION SHEAVES

Type	Groove	Belt Size	DD/PD	Bore Range
MVP Bushing Type	3-6	A, B, C, D, 5V, 8V	4.6-52.8	1/2-7 7/16"

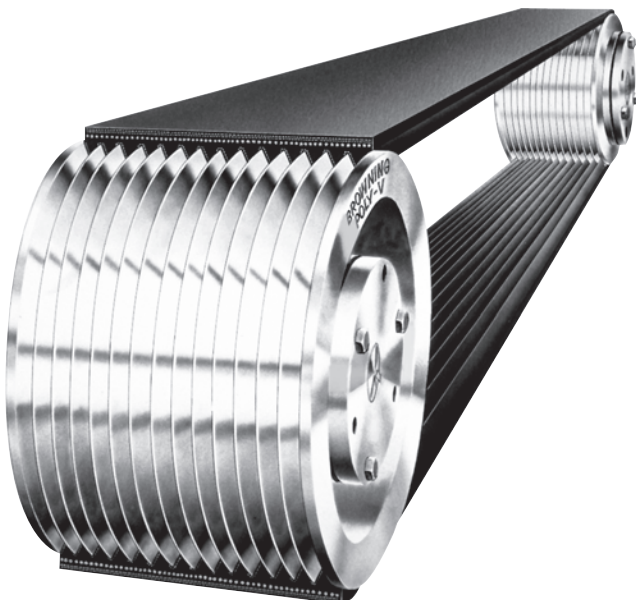

- **FHP drives** - Economical sheaves of pressed steel, zinc alloy and formed steel for lighter duty applications



FHP BELTS

Type	2L	3L	4L	5L
FHP	080-345	110-630	170-1000	230-1000

SINGLE GROOVE SHEAVES, Finished Bore

Type	Belt	DD/PD	Bore Range	
Bar Steel & Pressed Steel	AS, BS	4L/A, 5LB	1.25-18.4	1/2-1 7/16"
Die Cast	AZ, BZ, SCZ*	3L, 4L, 5L	1.25-13.75	3/8-1"
Lightweight Cast Iron (air moving)	OL, AL, AM	3L, 4L/A	4.8-14.0	1/2-1"

* Step Cone Sheave.

- **Poly-V®**, the multiple V-belt in a single unit -- eliminates belt matching, provides more horsepower in same space or same horsepower in less space. Over 400 stock sheave sizes, 1/4 HP and up

POLY-V® DRIVES

Cross Section	Grooves	Pitch Dia.	Bore Range*	Pitch Lengths
J-3/32" Rib	4-6	1.25-1.90"	FB 3/8-1"	18.0-98.0"
	4-16	2.00-10.60	3/8-2 11/16"	
L-3/16" Rib	6-20	3.00-30.00	1/2-3 3/4"	52.0-145.5"
	6-20	7.00-44.00	3/4-4 1/4"	90.0-198.0"

* FB = Finished Bore. Others are bushing type.

Poly-V is a registered trademark of RM Engineered Products, Inc.

All sales are made on our STANDARD TERMS AND CONDITIONS OF SALE in effect at the time a customer's order is accepted. The current Terms and Conditions are set forth below:

STANDARD TERMS AND CONDITIONS OF SALE (August 15, 2001)

These Terms and Conditions, the attendant quotation or acknowledgment and all documents incorporated by specific reference therein, will be the complete and exclusive statement of the terms of the agreement governing the sale of goods ("Goods") by **Emerson Power Transmission Corporation** and its divisions and subsidiaries ("Seller") to Customer ("Buyer"). Buyer's acceptance of the Goods will manifest Buyer's assent to these Terms and Conditions. If these Terms and Conditions differ in any way from the terms and conditions of Buyer's order, or other documentation, this document will be construed as a counteroffer and will not be deemed an acceptance of Buyer's terms and conditions which conflict herewith.

1. **PRICES:** Unless otherwise specified in writing by Seller, Seller's price for the goods shall remain in effect for thirty (30) days after the date of Seller's quotation or acknowledgment of Buyer's order for the Goods, whichever occurs first, provided an unconditional, complete authorization for the immediate shipment of the Goods is received and accepted by Seller within such time period. If such authorization is not received by Seller within such thirty (30) day period, Seller shall have the right to change the price for the Good to Seller's price for the Goods at the time of shipment.

2. **TAXES:** Any tax or governmental charge or increase in same hereafter becoming effective increasing the cost to Seller of producing, selling or delivering the Goods or of procuring material used therein, and any tax now in effect or increase in same payable by the Seller because of the manufacture, sale or delivery of the Goods, may at Seller's option, be added to the price.

3. **TERMS OF PAYMENT:** Subject to the approval of Seller's Credit Department, terms are net thirty (30) days from date of Seller's invoice in U.S. currency. If any payment owed to Seller is not paid when due, it shall bear interest, at a rate to be determined by Seller, which shall not exceed the maximum rate permitted by law, from the date on which it is due until it is paid. Seller shall have the right, among other remedies, either to terminate the Agreement or to suspend further performance under this and/or other agreements with Buyer in the event Buyer fails to make any payment when due. Buyer shall be liable for all expenses, including attorneys' fees, relating to the collection of past due amounts.

4. **SHIPMENT AND DELIVERY:** Shipments are made F.O.B. Seller's shipping point. Any claims for shortages or damages suffered in transit shall be submitted by the Buyer directly to the carrier. While Seller will use all reasonable commercial efforts to maintain the delivery date acknowledged or quoted by Seller, all shipping dates are approximate. Seller reserves the right to make partial shipments and to segregate "specials" and made-to-order Goods from normal stock Goods. Seller shall not be bound to tender delivery of any Goods for which Buyer has not provided shipping instructions.

5. **QUANTITY:** Buyer agrees to accept overruns of up to ten percent (10%) of the order on "made-to-order" Goods, including parts. Any such additional items shall be priced at the price per item charged for the specific quantity ordered.

6. **LIMITED WARRANTY:** Subject to the limitations of Section 7, Seller warrants that the Goods will be free from defects in material and workmanship under normal use, service and maintenance for a period of one year (unless otherwise specified by Seller in writing) from the date of shipment of the Goods by Seller. **THIS IS THE SOLE AND EXCLUSIVE WARRANTY GIVEN BY SELLER WITH RESPECT TO THE GOODS AND IS IN LIEU OF AND EXCLUDES ALL OTHER WARRANTIES, EXPRESS OR IMPLIED, ARISING BY OPERATION OF LAW OR OTHERWISE, INCLUDING WITHOUT LIMITATION, MERCHANTABILITY OR FITNESS FOR A PARTICULAR PURPOSE WHETHER OR NOT THE PURPOSE OR USE HAS BEEN DISCLOSED TO SELLER IN SPECIFICATIONS, DRAWINGS OR OTHERWISE, AND WHETHER OR NOT SELLER'S PRODUCTS ARE SPECIFICALLY DESIGNED AND/OR MANUFACTURED BY SELLER FOR BUYER'S USE OR PURPOSE.**

This warranty does not extend to any losses or damages due to misuse, accident, abuse, neglect, normal wear and tear, unauthorized modification or alteration, use beyond rated capacity, or improper installation, maintenance or application. To the extent that Buyer or its agents has supplied specifications, information, representation of operating conditions or other data to Seller in the selection or design of the Goods and the preparation of Seller's quotation, and in the event that actual operating conditions or other conditions differ from those represented by Buyer, any warranties or other provisions contained herein which are affected by such conditions shall be null and void. If within thirty (30) days after Buyer's discovery of any warranty defects within the warranty period, Buyer notifies Seller thereof in writing, Seller shall, at its option, repair or replace F.O.B. point of manufacture, or refund the purchase price for, that portion of the goods found by Seller to be defective. Failure by Buyer to give such written notice within the applicable time period shall be deemed an absolute and unconditional waiver of Buyer's claim for such defects. Goods repaired or replaced during the warranty period shall be covered by the foregoing warranty for the remainder of the original warranty period or ninety (90) days, whichever is longer. Buyer assumes all other responsibility for any loss, damage, or injury to persons or property arising out of, connected with, or resulting from the use of Goods, either alone or in combination with other products/components.

SECTIONS 6 AND 7 APPLY TO ANY ENTITY OR PERSON WHO MAY BUY, ACQUIRE OR USE SELLER'S GOODS, INCLUDING ANY ENTITY OR PERSON WHO BUYS THE GOODS FROM SELLER'S DISTRIBUTOR AND SUCH ENTITY OR PERSON SHALL BE BOUND BY THE LIMITATIONS THEREIN.

7. **LIMITATION OF REMEDY AND LIABILITY: THE SOLE AND EXCLUSIVE REMEDY FOR BREACH OF ANY WARRANTY HEREUNDER (OTHER THAN THE WARRANTY PROVIDED UNDER SECTION 13) SHALL BE LIMITED TO REPAIR, REPLACEMENT OR REFUND OF THE PURCHASE PRICE UNDER SECTION 6. SELLER SHALL NOT BE LIABLE FOR DAMAGES CAUSED BY DELAY IN PERFORMANCE AND IN NO EVENT, REGARDLESS OF THE FORM OF THE CLAIM OR CAUSE OF ACTION (WHETHER BASED IN CONTRACT, INFRINGEMENT, NEGLIGENCE, STRICT LIABILITY, OTHER TORT OR OTHERWISE), SHALL SELLER'S LIABILITY TO BUYER AND/OR ITS CUSTOMERS EXCEED THE PRICE TO BUYER OF THE SPECIFIC GOODS PROVIDED BY SELLER GIVING RISE TO THE CLAIM OR CAUSE OF ACTION. BUYER AGREES THAT IN NO EVENT SHALL SELLER'S LIABILITY TO BUYER AND/OR ITS CUSTOMERS EXTEND TO INCLUDE INCIDENTAL, CONSEQUENTIAL OR PUNITIVE DAMAGES. THE TERM "CONSEQUENTIAL DAMAGES" SHALL INCLUDE, BUT NOT BE LIMITED TO, LOSS OF ANTICIPATED PROFITS, LOSS OF USE, LOSS OF REVENUE, COST OF CAPITAL AND DAMAGE OR LOSS OF OTHER PROPERTY OR EQUIPMENT.**

304

It is expressly understood that any technical advice furnished by Seller with respect to the use of the Goods is given without charge, and Seller assumes no obligation or liability for the advice given, or results obtained, all such advice being given and accepted at Buyer's risk.

GOODS AND/OR SERVICES SOLD HEREUNDER ARE NOT FOR USE IN ANY NUCLEAR AND RELATED APPLICATIONS. Buyer accepts goods and/or services with the foregoing understanding, agrees to communicate the same in writing to any subsequent purchaser or users and to defend, indemnify and hold harmless Seller from any claims, losses, suits, judgments and damages, including incidental and consequential damages, arising from such use, whether the cause of action be based in tort, contract or otherwise, including allegations that the Seller's liability is based on negligence or strict liability.

8. **EXCUSE OF PERFORMANCE:** Seller shall not be liable for delays in performance or for non-performance due to acts of God, acts of Buyer, war, riot, fire, flood, other severe weather, sabotage, or epidemics; strikes or labor disturbances; governmental requests, restrictions, laws, regulations, orders or actions; unavailability of or delays in transportation; default of suppliers; or unforeseen circumstances or any events or causes beyond Seller's reasonable control. Deliveries may be suspended for an appropriate period of time as a result of the foregoing. If Seller determines that its ability to supply the total demand for the Goods, or to obtain material used directly or indirectly in the manufacture of the Goods, is hindered, limited or made impracticable due to causes addressed in this Section 8, Seller may allocate its available supply of the Goods or such material (without obligation to acquire other supplies of any such Goods or material) among itself and its purchasers on such basis as Seller determines to be equitable without liability for any failure of performance which may result therefrom. Deliveries suspended or not made by reason of this section may be canceled by Seller upon notice to Buyer without liability, but the balance of the agreement shall otherwise remain unaffected.

9. **CANCELLATION:** The Buyer may cancel orders only upon written notice and upon payment to Seller of cancellation charges which include, among other things, all costs and expenses incurred and commitments made by the Seller and a reasonable profit thereon.

10. **CHANGES:** Buyer may request changes or additions to the Goods consistent with Seller's specifications and criteria. In the event such changes or additions are accepted by Seller, Seller may revise the price and delivery schedule. Seller reserves the right to change designs and specifications for the Goods without prior notice to Buyer, except with respect to Goods being made-to-order for Buyer.

11. **TOOLING:** Tool, die, and pattern charges, if any, are in addition to the price of the Goods and are due and payable upon completion of the tooling. All such tools, dies and patterns shall be and remain the property of Seller. Charges for tools, dies, and patterns do not convey to Buyer, title, ownership interests in, or rights to possession or removal, nor prevent their use by Seller for other purchasers, except as otherwise expressly provided by Seller and Buyer in writing with reference to this provision.

12. **ASSIGNMENT:** Buyer shall not assign its rights or delegate its duties hereunder or any interest therein or any rights hereunder without the prior written consent of the Seller, and any such assignment, without such consent, shall be void.

13. **PATENTS AND COPYRIGHTS:** Subject to Section 7, Seller warrants that the Goods sold, except as are made specifically for Buyer according to Buyer's specifications, do not infringe any valid U.S. patent or copyright in existence as of the date of delivery. This warranty is given upon the condition that Buyer promptly notify Seller of any claim or suit involving Buyer in which such infringement is alleged, and, that Buyer cooperate fully with Seller and permit Seller to control completely the defense or compromise of any such allegation of infringement. Seller's warranty as to use only applies to infringements arising solely out of the inherent operation (i) of such Goods, or (ii) of any combination of Goods in a system designed by Seller. In the event such Goods, singly or in combination, are held to infringe a U.S. patent or copyright in such suit, and the use of such Goods is enjoined, or in the case of a compromise by Seller, Seller shall have the right, at its option and expense, to procure for Buyer the right to continue using such Goods, or replace them with non-infringing Goods; or modify same to become non-infringing; or grant Buyer a credit for the depreciated value of such Goods and accept return of them.

14. **MISCELLANEOUS:** These terms and conditions set forth the entire understanding and agreement between Seller and Buyer, and supersede all other communications, negotiations and prior oral or written statements regarding the subject matter of these terms and conditions. No change, modification, rescission, discharge, abandonment, or waiver of these terms and conditions of Sale shall be binding upon the Seller unless made in writing and signed on its behalf by an officer of the Seller. No conditions, usage or trade, course of dealing or performance, understanding or agreement purporting to modify, vary, explain, or supplement these Terms and Conditions shall be binding unless hereafter made in writing and signed by the party to be bound, and no modification shall be affected by the acceptance of purchase orders or shipping instruction forms containing terms at variance with or in addition to those set forth herein. Any such modifications or additional terms are specifically rejected by Seller. No waiver by Seller with respect to any breach or default or any right or remedy and no course of dealing, shall be deemed to constitute a continuing waiver of any other breach or default or of any other right or remedy, unless such waiver be expressed in writing and signed by the party to be bound. Seller is not responsible for typographical or clerical errors made in any quotation, orders or publications. All such errors are subject to correction. The validity, performance, and all other matters relating to the interpretation and effect of this contract shall be governed by the law of the state of New York. The United Nations Convention on the International Sale of Goods shall not apply to any transaction hereunder.